

Practice Paper 2

Scan here to return to the course
or visit [savemyexams.com](https://www.savemyexams.com)

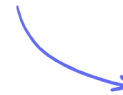

Total Marks

/50

- 1 (a) A packing company have a contraption involving an inclined plane and a spring. It is used to pack and seal their boxes.

A box of mass 4800 g with an initial speed 21.96 km h^{-1} begins to move up a smooth incline.

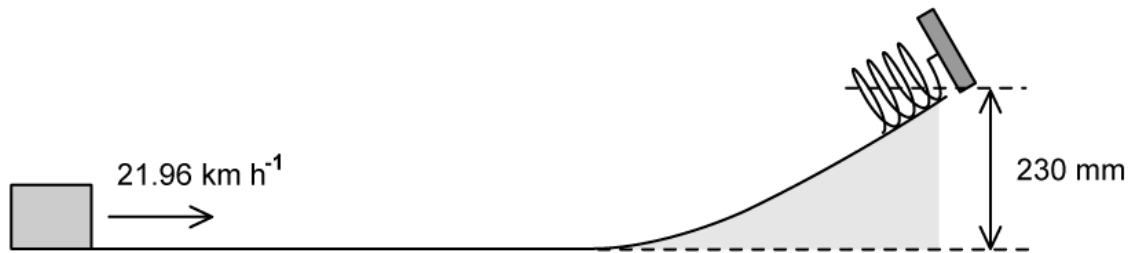

The box is momentarily brought to rest after colliding with a spring of spring constant 195 N m^{-1} . It stops a vertical distance of 230 mm above its initial position.

- (a) Calculate the compression of the spring in mm.

[3]

(3 marks)

- (b) On a different set up, the inclined plane is rough and has a coefficient of friction of 0.3. A new box comes to rest part way up the slope after 2.12 seconds.

- (b) Determine the height the box reaches at the point it comes to rest.

You may use the result:

$$\tan \theta = \frac{\sin \theta}{\cos \theta}$$

[4]

(4 marks)

2 (a) Light is incident upon a piece of glass.

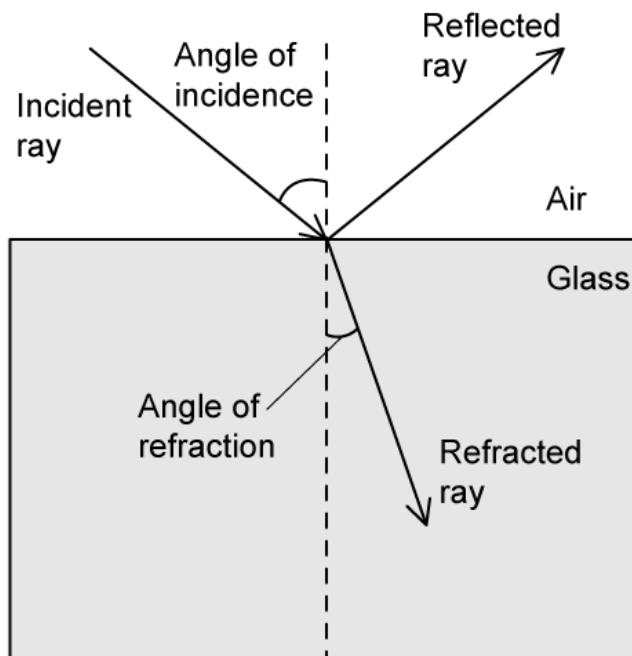

The angle of incidence is less than that of the critical angle. The refractive index of the glass is 1.50.

(a) Explain what is meant by the 'critical angle' and what will occur at angles that are above and below the critical angle.

(3 marks)

(b) The angle of incidence for this situation is 34° .

(b) Determine the angle of refraction to the nearest degree.

(2 marks)

(c) The refracted light travels within the glass for 5 m.

(c) Determine the time that the light will take to travel this distance in the glass.

(2 marks)

(d) The light continues within the glass until it strikes the side perpendicular to the original side of entry.

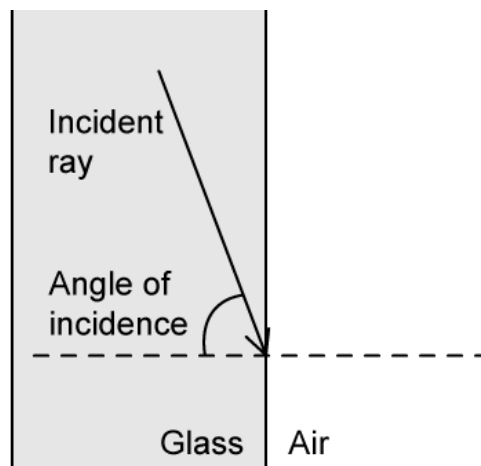

(d) Show that the light will not emerge from the side of the glass.

(3 marks)

3 (a) An industrial kiln is used for 'firing' ceramic and pottery items at very high temperatures.

The kiln emits electromagnetic radiation of peak wavelength, $\lambda_{\text{max}} = 3.50 \times 10^{-6} \text{ m}$.

(a) Determine the temperature, in degrees Celsius, of the kiln. You can treat the kiln as an ideal black body.

(2 marks)

(b) The kiln has a surface area of 160 m^2 .

(b) Calculate the energy radiated per second.

(3 marks)

(c) The large kiln is compared to a smaller model with a surface area of 120 m^2 and a lower operating temperature of 710 K . The smaller kiln is made from the same materials and can also be treated as an ideal black body.

(c) Determine the ratio of power radiated for the large kiln to the small kiln.

(2 marks)

(d) The working areas and people around kilns need to be protected from the high levels of heat energy emitted.

(d) With reference to the mechanisms by which heat energy is transferred, outline how protection from heat energy could be achieved.

(3 marks)

- 4 (a) A variable resistor R_1 has a resistance that varies between 0 and $10\ \Omega$ is connected to two resistors R_2 and R_3 and two cells of e.m.f. 5 V and 6 V.

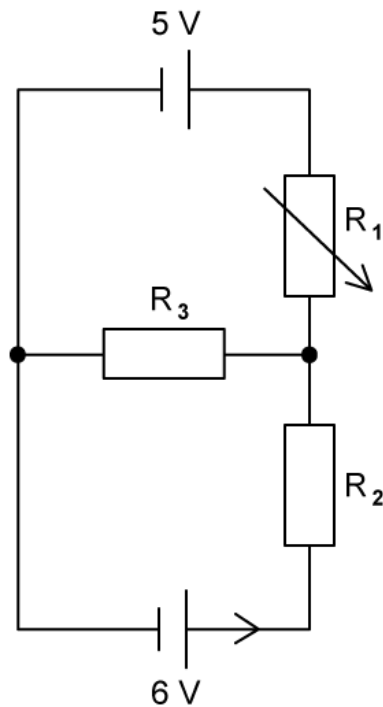

- (a) Use Kirchhoff's junction law to deduce an equation for three currents I_1 , I_2 and I_3 at the junction between the resistors R_1 , R_2 and R_3 .

.....

.....

(2 marks)

- (b) Initially, the variable resistor R_1 is set to $0\ \Omega$.

- (b) If R_2 is $5\ \Omega$ and R_3 is $10\ \Omega$, determine the current through resistor R_2 .

.....

.....

.....

.....

(4 marks)

- (c) The terminals of the 5 V cell are reversed, and the variable resistor is set to a resistance of 5Ω .

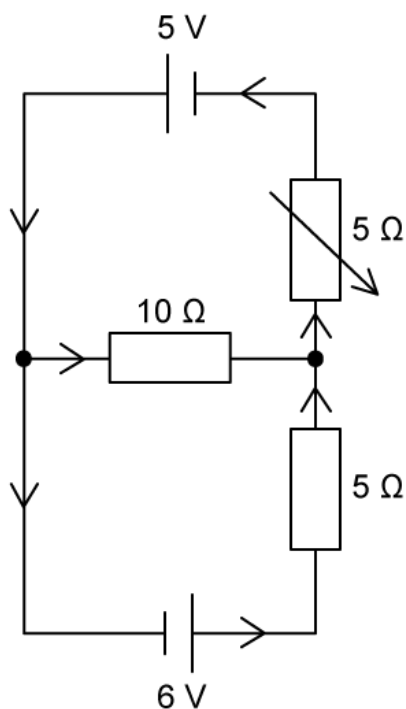

- (c) Using the current directions indicated, write:
- Two unique equations using Kirchhoff's circuit law for loops.
 - One equation using Kirchhoff's circuit law for junctions.

.....

.....

.....

(3 marks)

- (d) (d) Hence, calculate the power dissipated in R_3 .

.....

.....

.....

(4 marks)

(a)
5 (a) (i) State two particles that are their own antiparticle.

[2]

(ii) Explain why K^0 is not its own antiparticle.

[1]

(3 marks)

(b) (b) The K^0 meson decays into two pions and has a strangeness of 1. State the decay equation at the quark level for the K^0 meson.

[3]

(3 marks)

(c) Heavier quarks can decay into lighter quarks by exchanging a virtual particle that mediates the type of interaction. This particle can then decay into a quark and its equivalent anti-quark.

(c) Draw a Feynman diagram for the decay of the K^0 meson at the quark level. Clearly label the K^0 meson and the two pions.

[4]

(4 marks)