

Structured Questions

Kinematics

Distance & Displacement / Speed & Velocity / Acceleration / Kinematic Equations / Motion Graphs / Projectile Motion / Fluid Resistance / Terminal Speed

Easy (5 questions)	/50
Medium (5 questions)	/63
Hard (4 questions)	/40
Total Marks	/153

Scan here to return to the course
or visit [savemyexams.com](https://www.savemyexams.com)

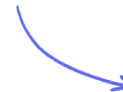

Easy Questions

- 1 (a) One end of an elastic climbing rope is fixed to the top of a crane. The other end of the rope is connected to a block which is initially at position A. The block is released from rest. The mass of the rope is negligible.

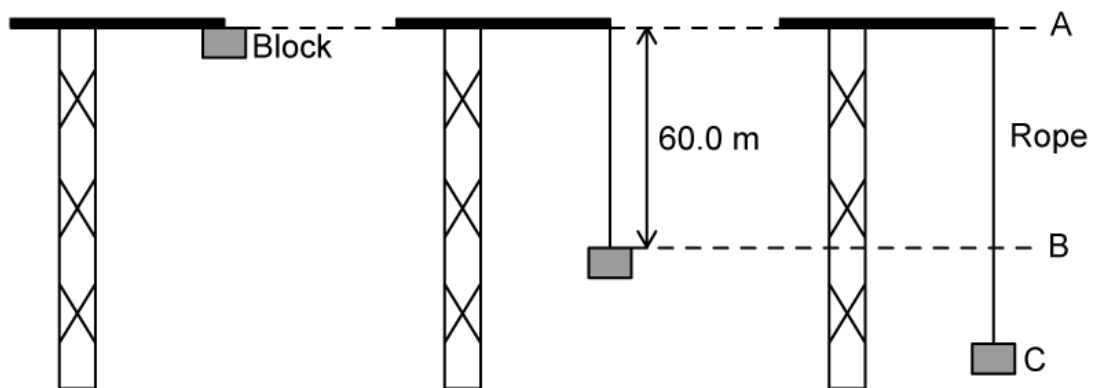

The full length of the rope is 60.0 m. From position A to B, the block falls freely.

- (i) State the block's acceleration between position A and B. [1]
- (ii) Describe how the velocity of the block changes between position A and B. [1]

(2 marks)

- (b) Calculate the speed of the block at position B.

(2 marks)

- (c) At position B the rope starts to extend. Position C is the point at which the rope is fully extended. Describe the motion of the block between position B and C.

(2 marks)

- (d)** Between position B and C the resultant force on the block changes, because the tension in the rope increases as the rope extends.

State and explain whether a SUVAT equation can be used to determine the distance the block falls between position B and C.

(2 marks)

- 2 (a) An experimenter throws a small object upwards. The graph shows the variation of velocity v with time t of the object.

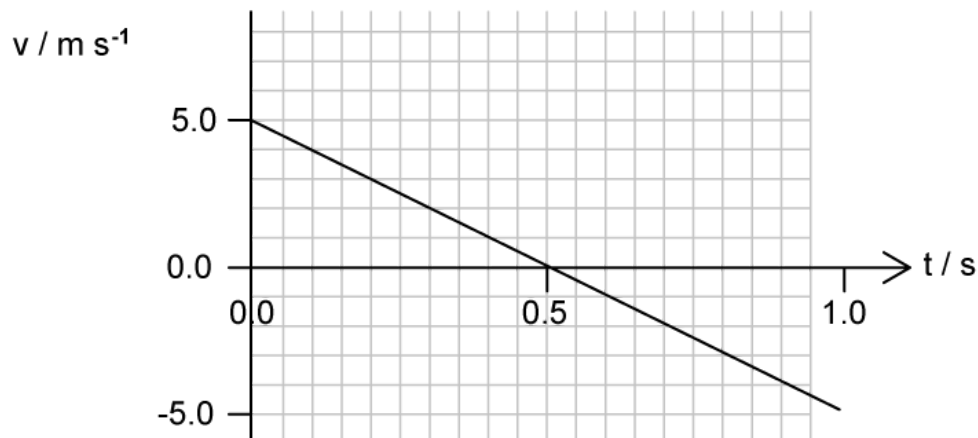

Explain why the gradient of the graph between $t = 0.0 \text{ s}$ and $t = 0.5 \text{ s}$ is roughly 10 m s^{-2} .

.....

.....

(2 marks)

- (b) Use the graph to calculate the displacement of the object between $t = 0 \text{ s}$ and $t = 0.5 \text{ s}$.

.....

.....

.....

(3 marks)

- (c) State and explain the motion of the object at $t = 0.5 \text{ s}$.

.....

.....

(2 marks)

- (d) The experimenter states that the velocity-time graph shows the object travels the same distance upwards and it does downwards.

Explain how the velocity-time graph shows the distance travelled by the object is the same upwards as it is downwards.

(2 marks)

3 (a) Examination questions on projectile motion often involves objects moving vertically through the atmosphere.

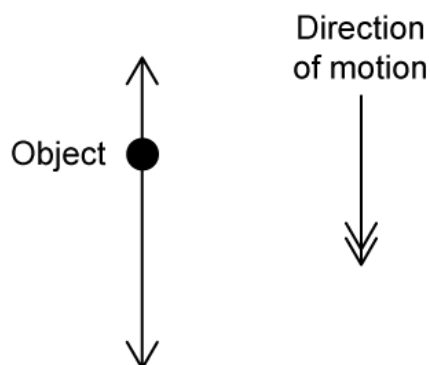

The object shown moves vertically downwards through the atmosphere.

Identify the two forces acting on the object and label them on the diagram.

(2 marks)

(b) Often, a simplifying condition is assumed so that, in these cases, only a single force acts on objects as they move through the atmosphere.

(i) State the simplifying condition that is normally assumed.

[1]

(ii) Identify the force that is ignored under this simplifying condition.

[1]

(2 marks)

(c) Terminal velocity is only attained if both forces act on the object.

State and explain the magnitude of the resultant force on the object if it moves at its terminal velocity.

(2 marks)

- (d) Sketch a graph on the axes provided to show an object that is released from rest at $t = 0$ s and falls vertically through the atmosphere, attaining terminal velocity, v_{terminal} after $t = 4$ s.

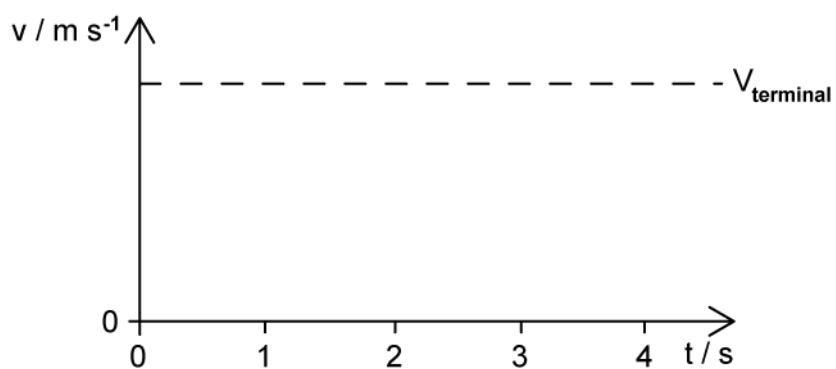

The line corresponding to v_{terminal} is included as guidance.

(3 marks)

- 4 (a) Projectiles follow parabolic trajectories. One such trajectory is shown for a projectile fired from a bazooka.

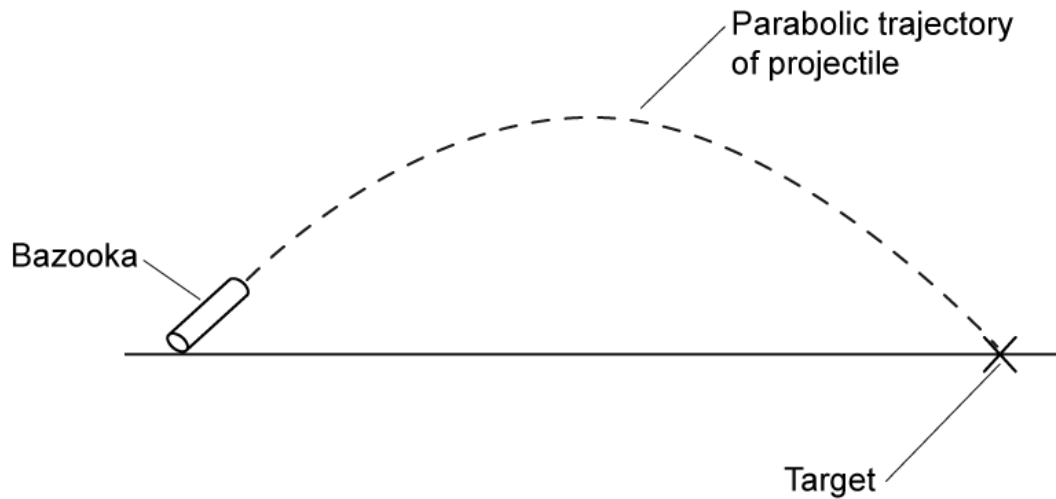

The projectile lands on its target with a final velocity v that can be represented as shown.

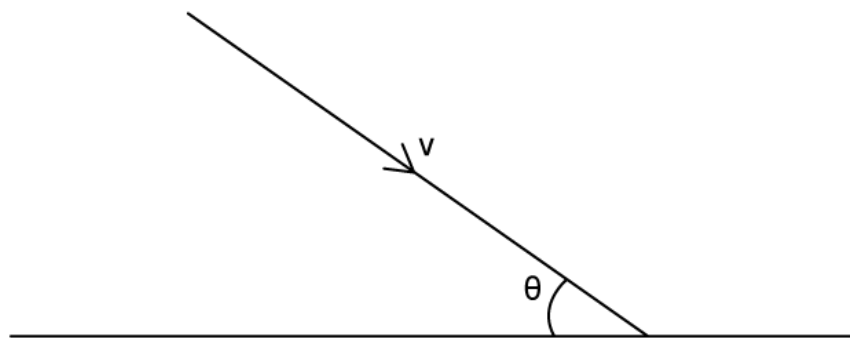

- (i) Draw and label the direction of the horizontal and vertical components of the final velocity v on the diagram. [2]
- (ii) Write the magnitude of each component in terms of the angle to the horizontal, θ . [2]

.....

.....

.....

.....

(4 marks)

(b) The initial horizontal velocity given to the projectile is 3.5 m s^{-1} . Air resistance can be ignored.

(i) State the final horizontal velocity of the projectile.

[1]

(ii) Explain your answer to part (i).

[1]

(2 marks)

(c) The final vertical velocity of the projectile is 3.8 m s^{-1} .

Calculate the magnitude of the final velocity, v .

(3 marks)

(d) The horizontal distance between the bazooka and the target is 27 m.

Calculate the time taken for the projectile to reach the target.

(3 marks)

5 (a) The following quantities are used to describe the motion of an object:

Distance Acceleration Velocity Displacement Speed

Complete the table by placing a tick (✓) in the correct column to indicate whether each of the quantities are scalars or vectors.

Quantity	Vector	Scalar
Distance		
Acceleration		
Velocity		
Displacement		
Speed		

.....

.....

.....

.....

.....

(5 marks)

(b) A runner completes a full lap of a 200 m running track in a time of 63.4 s.

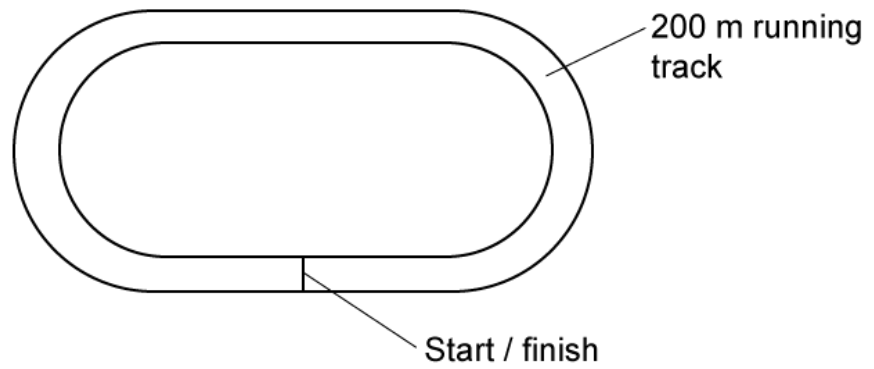

Calculate the average speed of the runner over the entire lap.

.....

.....

.....

(3 marks)

(c) State the average velocity of the runner over the entire lap and explain your answer.

.....

.....

.....

(3 marks)

(d) Define instantaneous velocity.

.....

(1 mark)

Medium Questions

- 1 (a) A ball is projected horizontally at 27 m s^{-1} from a vertical cliff. It travels a horizontal distance of 40 m before hitting the ground.

Assume that air resistance is negligible.

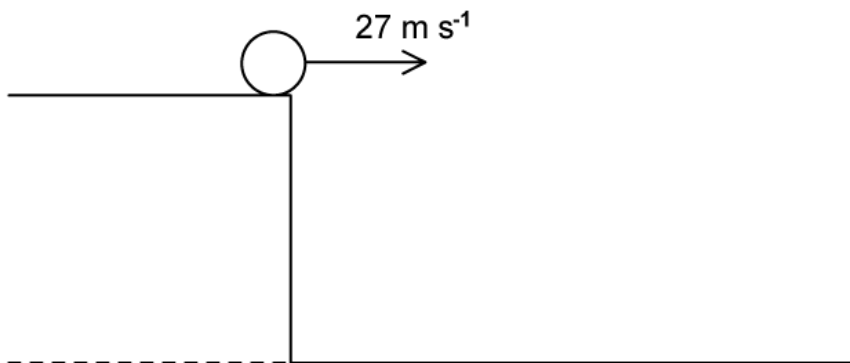

Calculate the vertical velocity of the ball just before it hits the ground.

(4 marks)

- (b) Calculate the height of the cliff.

(2 marks)

- (c) Sketch the graphs to show how the horizontal and vertical components of the velocity of the ball, v_x and v_y change with time t just before the ball hits the ground.

Label any appropriate values on the axes.

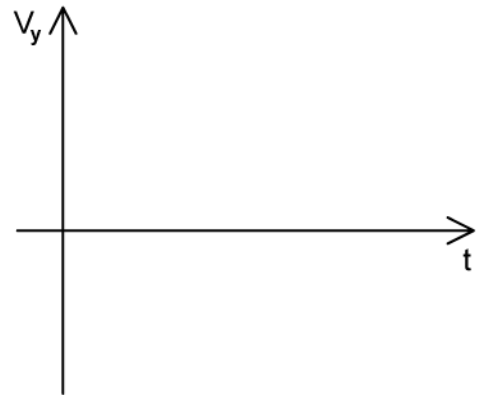
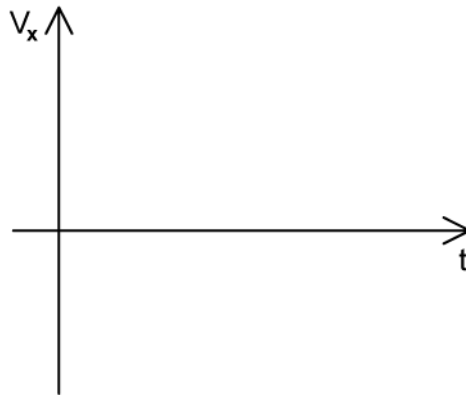

(3 marks)

(d) Calculate the resultant velocity of the ball just before it hits the ground.

(2 marks)

2 (a) Naomi stands on the edge of a vertical cliff and throws a stone vertically upwards.

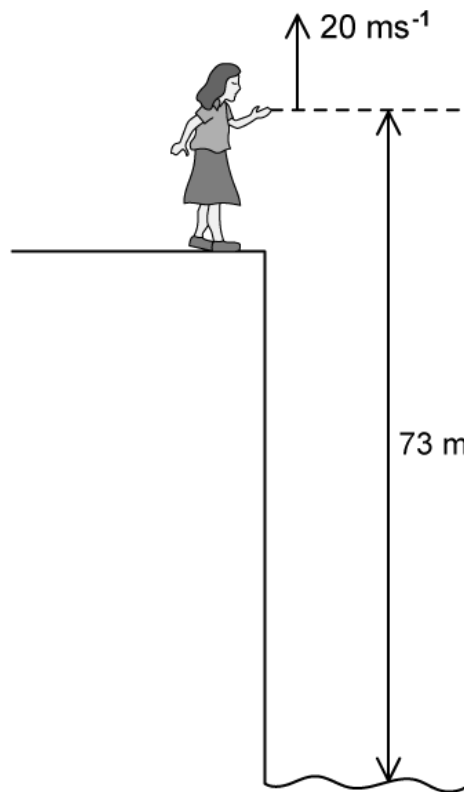

The stone leaves her hand with a speed of 20 m s^{-1} at the instant her hand is 73 m above the surface of the sea. Air resistance is negligible.

Calculate the maximum height reached by the stone as measured from the point it was thrown.

.....

.....

(2 marks)

(b) Determine the time taken for the stone to pass by the point from which it was released.

.....

.....

.....

(3 marks)

(c) Calculate the time taken for the stone to land in the sea after leaving Naomi's hand.

(4 marks)

(d) Sketch the graph to show how the displacement s of the stone changes with time t from when it is thrown in the air to when it touches the surface of the sea.

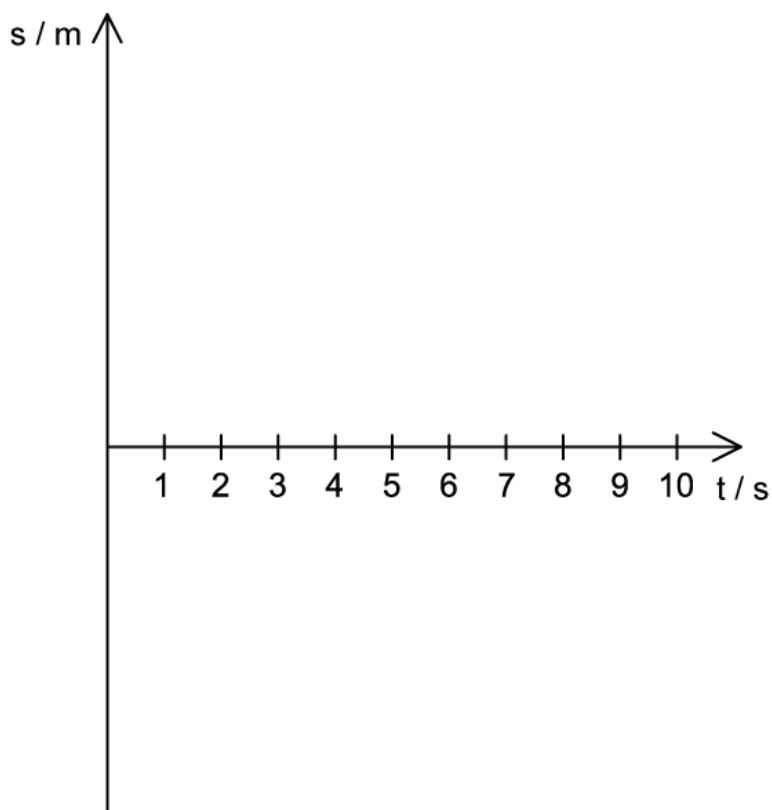

(3 marks)

3 (a) The graph shows how the velocity v of a particle varies with time t .

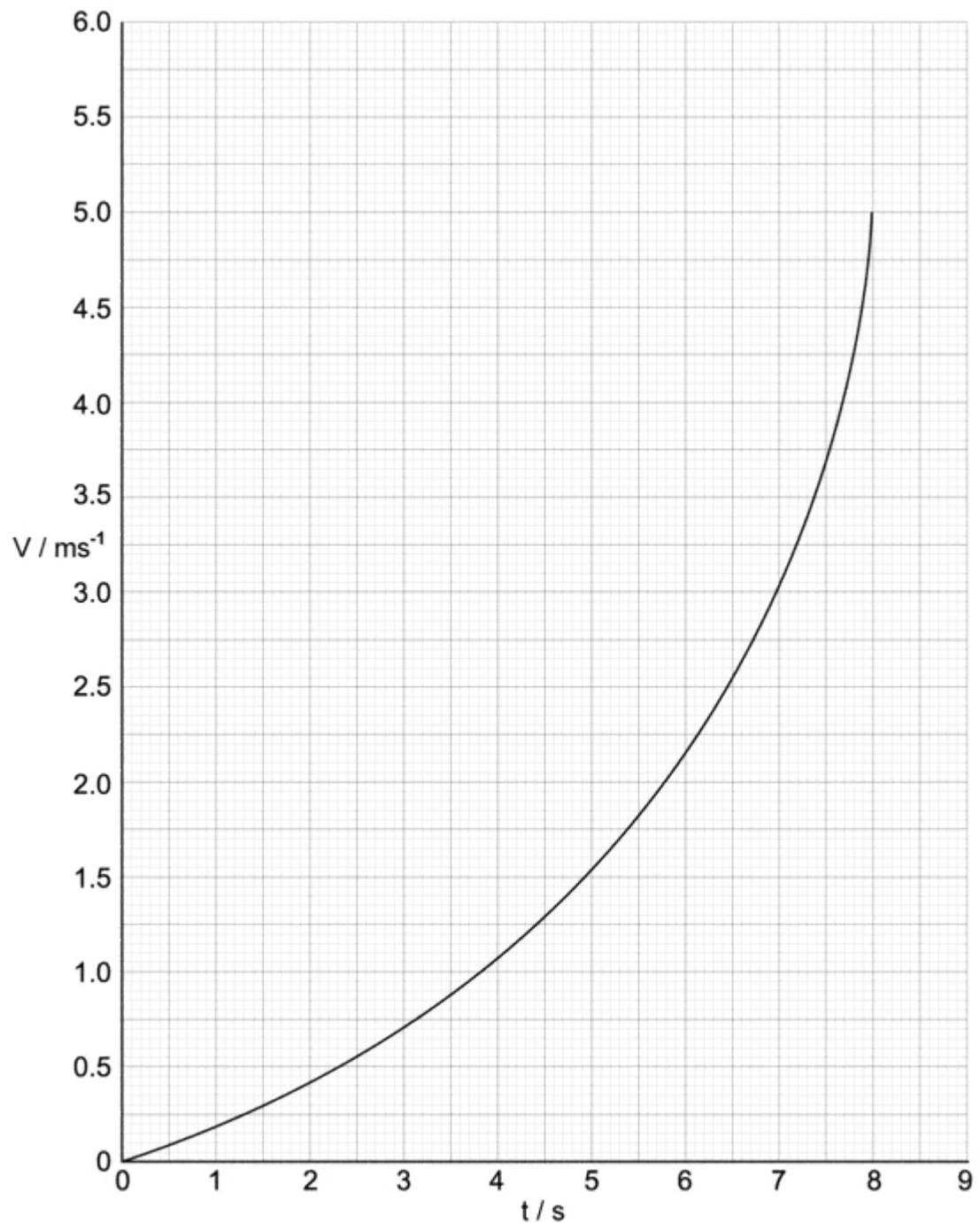

At time $t = 0$ the instantaneous velocity of the particle is 0.

Calculate the instantaneous acceleration of the particle at time $t = 6$ s.

(3 marks)

- (b)** The velocity of the particle, as shown on the graph on part (a), is its vertical velocity. At $t = 5$ s, its horizontal velocity is 2.5 m s^{-1} .

Calculate the angle of the particle from the horizontal at $t = 5$ s.

(3 marks)

- (c)** A different particle falls under gravity for 0.7 m from rest. Assume that air resistance is negligible.

Calculate:

- (i) The final velocity of the particle.
- (ii) The time when it first reaches this velocity.

(4 marks)

- (d)** A third particle now falls under the effect of both gravity and air resistance.

After falling for some time, its resultant force becomes zero for the rest of its motion. It reaches the same final velocity in the same time as the second particle, where air resistance was not present.

Sketch the motion of this third particle on the graph in part (a).

(2 marks)

4 (a) Describe how the fluid resistance on an object in free fall means it reaches a terminal velocity.

(5 marks)

(b) A bird drops a spherical graphite rock of density 2230 kg m^{-3} and radius 3 cm vertically down a water well. After it hits the water surface, it rapidly reaches a terminal speed as it falls through the well.

Calculate the magnitude of the fluid resistance from the water on the rock whilst it travels at terminal speed.

(4 marks)

(c) The bird drops the rock 14 m above the water's surface. t_1 is the time when the rock hits the water surface and t_2 is when the rock is at rest at the bottom of the well, which is 70 m deep.

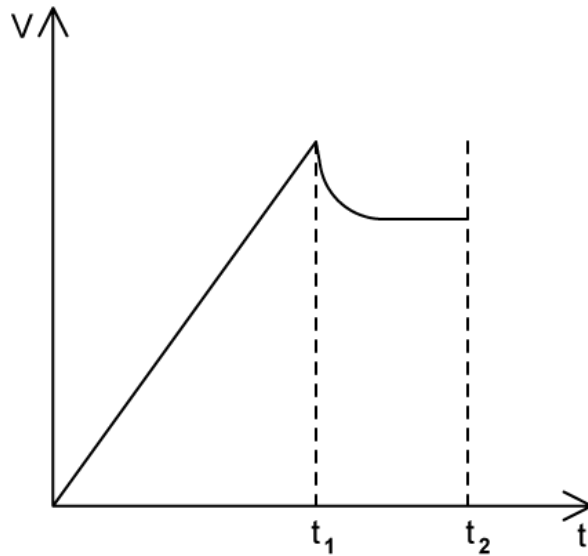

Determine the value of t_1 .

(2 marks)

(d) Calculate the speed at which the rock hits the water.

(3 marks)

- 5 (a) Two identical balls are dropped from rest from the same height. One of the balls is dropped 1.50 s after the other.

Calculate the distance that separates the two balls 3.00 s after the second ball is dropped.

(4 marks)

- (b) Draw the displacement–time graphs for both balls.

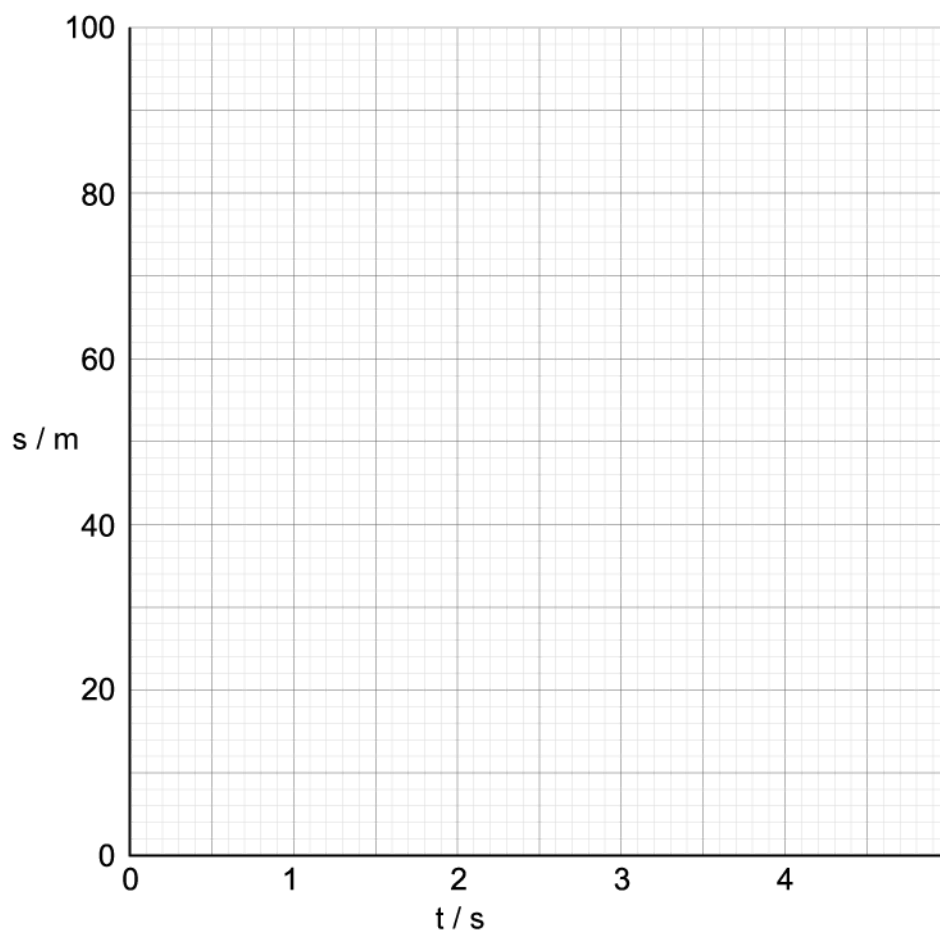

(3 marks)

- (c) One of the balls is now dropped from the same height again from rest. After 2 seconds, it enters a cylinder of oil where it then no longer accelerates.

Sketch on the displacement–time graph the motion of this ball.

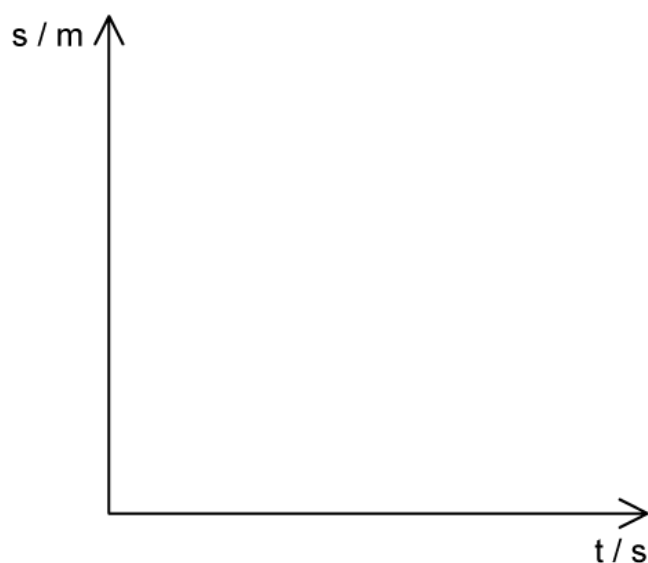

(3 marks)

- (d) A different ball, that is identical in every way but is much heavier than the first two is now dropped from a certain height. Again, after 2 seconds, it enters a cylinder of oil where it then no longer accelerates.

Compare and contrast how the displacement–time graph from part (c) would change for this heavier ball. Assume that air resistance is negligible.

(4 marks)

Hard Questions

1 (a) A rock is thrown off a cliff at a height of 150 m and lands 90 m away.

(i) Calculate the speed at which it was thrown.

[2]

(ii) State an assumption required to obtain your answer.

[1]

(3 marks)

(b) Determine the angle at which the rock makes impact with the ground.

(2 marks)

(c) The rock is loaded into a catapult and is launched at 40° elevation from the ground toward a castle wall, with a speed of 27 m s^{-1} . The castle wall is 50 m away and is 12 m high.

Determine whether the rock makes it over the wall.

(4 marks)

- (d) Prove that the maximum range of any projectile that starts and ends at ground level is achieved when launched at an angle of elevation of 45° .

You may wish to use the double angle formula:

$$\sin 2A = 2 \sin A \cos A$$

(4 marks)

- 2 (a)** A truck driver's initial speed is 4.0 m s^{-1} when they begin to accelerate at 6.0 m s^{-2} . After 3.0 seconds, they decelerate at 5.0 m s^{-2} to stop at a set of traffic lights.

Calculate the distance between the traffic lights and the point where the truck began to accelerate.

(4 marks)

- (b)** Draw the velocity-time graph on the axes provided for the motion of the truck in part (a).

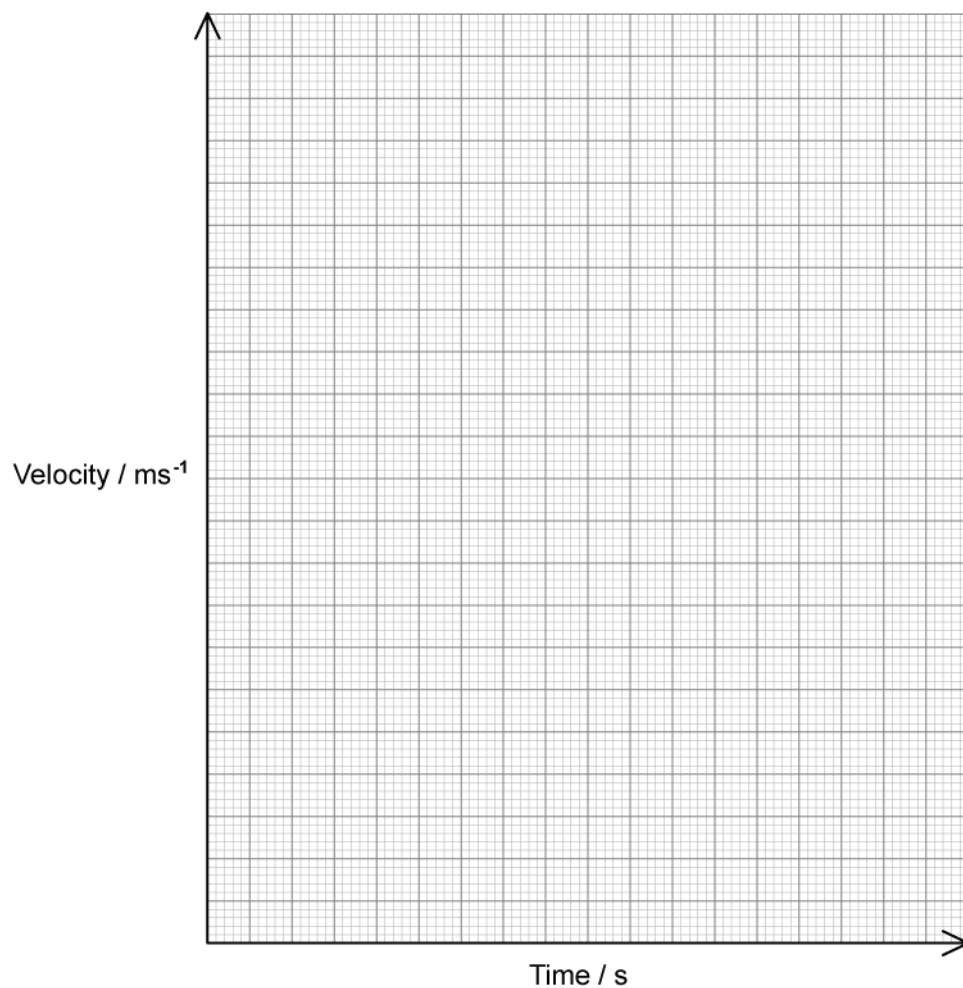

(4 marks)

- (c) Sketch the displacement-time and acceleration-time graphs for the truck on the pair of axes provided. Label each axes appropriately.

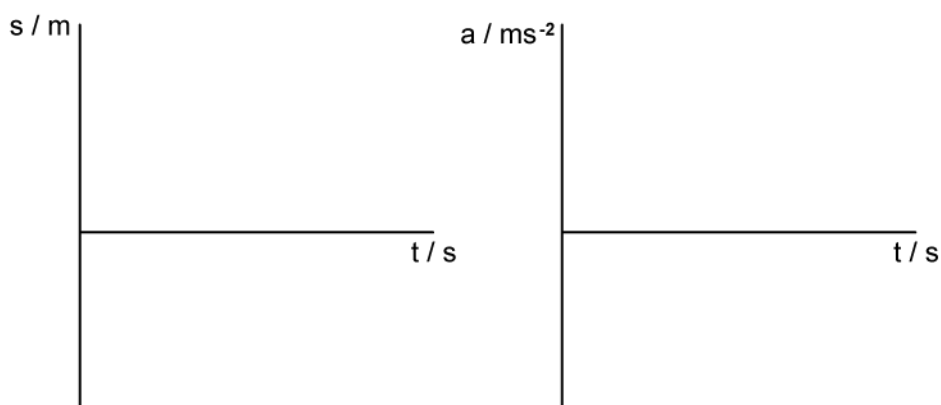

(4 marks)

- 3 (a) An object is released near the surface of the Moon at time $t = 0$. The graph shows the variation of displacement s with time t of the object from the point of release.

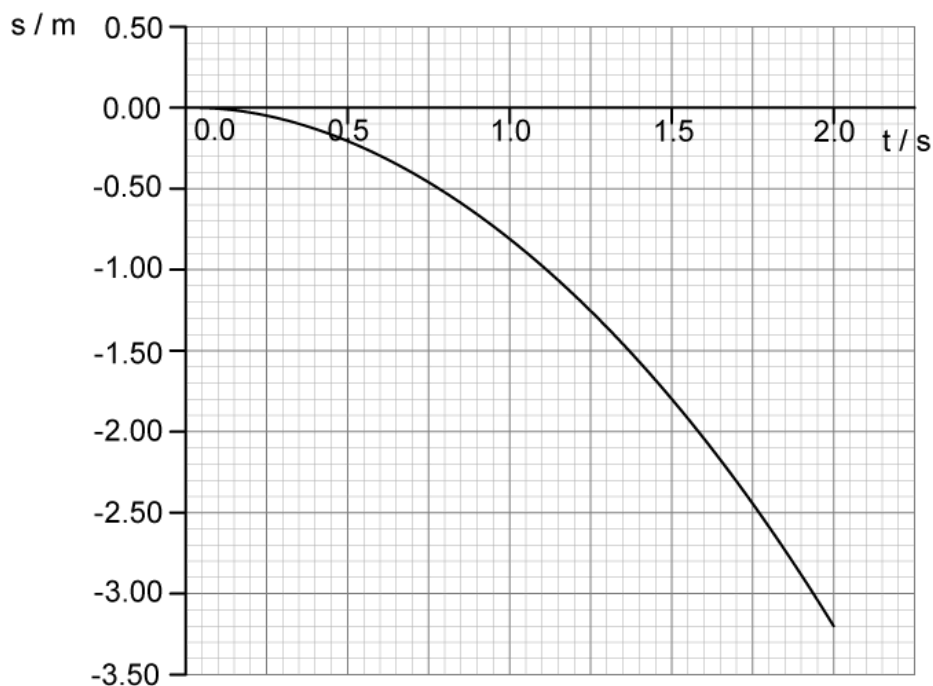

- (i) State the significance of the negative values of s [1]
- (ii) State an assumption about the point of release of the object. [1]

(2 marks)

- (b) Use the graph to determine a value for the acceleration of free fall close to the surface of the Moon.

(2 marks)

- (c) Use the graph to estimate the instantaneous velocity of the object at $t = 1.5$ s.

(3 marks)

(d) (i) Sketch, on the axes provided in part (a), a graph that would show the variation of displacement s with time t if the same object was released close to the surface of the Earth.

[2]

(ii) Describe and explain the features of your sketch.

[2]

(4 marks)

- 4 (a) A projectile is launched from sea level with an initial velocity v at an angle of θ above the ground.

On the axes below, sketch graphs to show how the horizontal and vertical components of the velocity of the ball v_x and v_y change with time t until the projectile hits the ground.

Assume that air resistance is negligible.

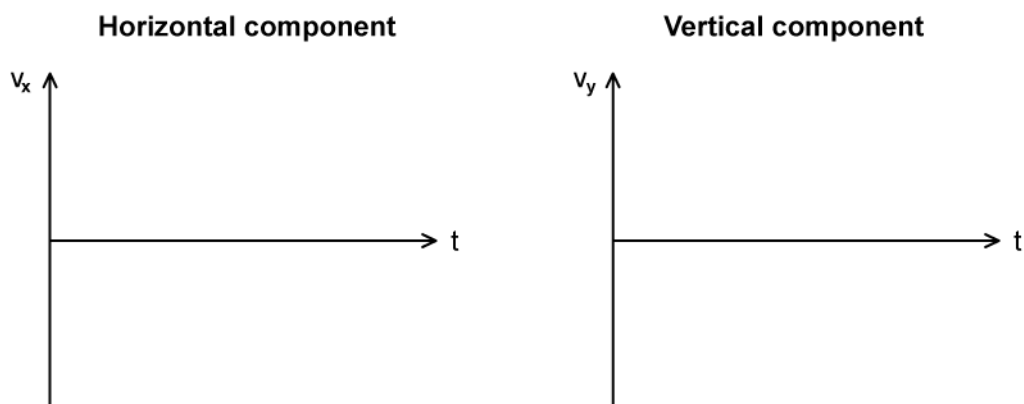

(2 marks)

- (b) The launch location and point of impact of the ball in relation to the ground are shown in the diagram.

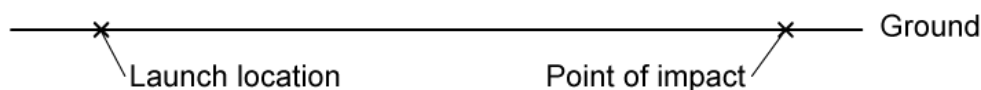

On the diagram, sketch the trajectory of the ball when:

- (i) the effects of fluid resistance are negligible. Label this line X. [1]
- (ii) the effects of fluid resistance are not negligible. Label this line Y. [1]

(2 marks)