

HL IB Physics



Your notes

Processing Uncertainties

Contents

- * Random & Systematic Errors
- * Calculating Uncertainties
- * Determining Uncertainties from Graphs



Your notes

Random & Systematic Errors

Random & Systematic Errors

- Measurements of quantities are made with the aim of finding the true value of that quantity
 - In reality, it is impossible to obtain the true value of any quantity as there will always be a degree of **uncertainty**
- The uncertainty is an estimate of the difference between a **measurement reading** and the **true value**
- The two types of **measurement errors** that lead to uncertainty are:
 - Random errors
 - Systematic errors

Random Errors

- Random errors cause unpredictable fluctuations in an instrument's readings as a result of uncontrollable factors, such as environmental conditions
- This affects the precision of the measurements taken, causing a wider spread of results about the mean value
- To **reduce** random error:
 - **Repeat** measurements several times and calculate an average from them

Reading Errors

- When measuring a quantity using an **analogue** device such as a ruler, the uncertainty in that measured quantity is **± 0.5 the smallest measuring interval**
- When measuring a quantity using a **digital** device such as a digital scale or stopwatch, the uncertainty in that measured quantity is **± 1 the smallest measuring interval**
- To **reduce** reading errors:
 - Use a **more precise** device with **smaller measuring intervals** and therefore less uncertainty

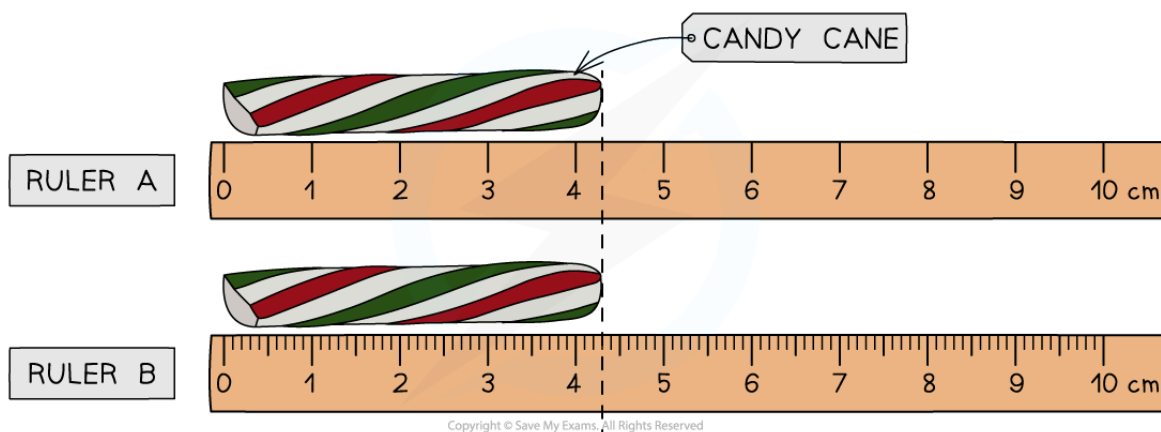

Both rulers measure the same candy cane, yet Ruler B is more precise than Ruler A due to a smaller interval size

Systematic Errors

- Systematic errors arise from the use of faulty instruments or from flaws in the experimental method
- This type of error is repeated consistently every time the instrument is used or the method is followed, which affects the accuracy of all readings obtained
- To **reduce** systematic errors:
 - Instruments should be **recalibrated**, or different instruments should be used
 - Corrections or adjustments should be made to the technique

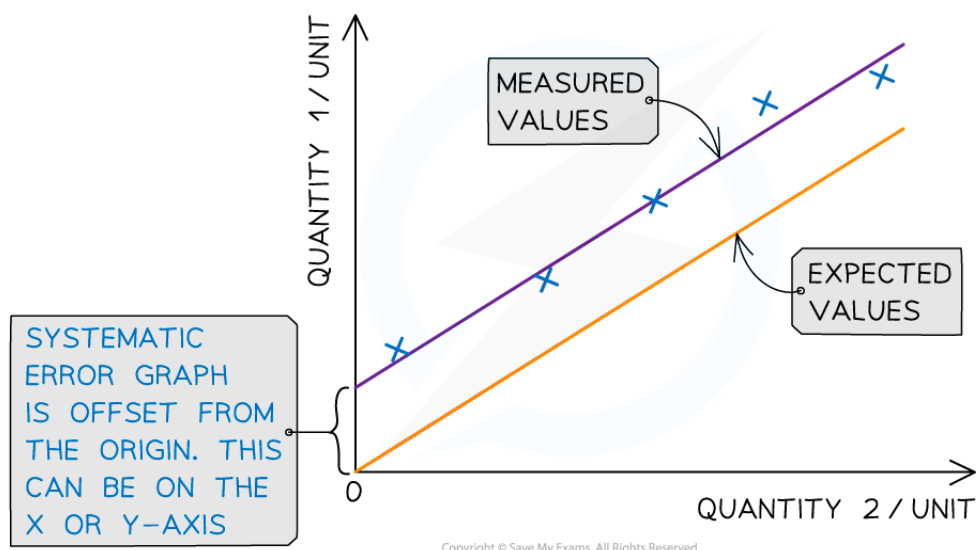

Systematic errors on graphs are shown by the offset of the line from the origin



Your notes

Zero Errors

- This is a type of systematic error which occurs when an instrument gives a reading when the **true reading is zero**
 - For example, a top-ban balance that starts at 2 g instead of 0 g
- To **account for** zero errors
 - Take the **difference** of the **offset** from each value
 - For example, if a scale starts at 2 g instead of 0 g, a measurement of 50 g would actually be $50 - 2 = 48$ g
 - The offset could be positive or negative

Precision

- Precise measurements are ones in which there is **very little spread** about the **mean** value, in other words, **how close** the measured values are **to each other**
- If a measurement is repeated several times, it can be described as **precise** when the values are **very similar to, or the same** as, each other
 - Another way to describe this concept is if the **random uncertainty** of a measurement is **small**, then that measurement can be said to be **precise**
- The precision of a measurement is reflected in the values recorded – measurements to a greater number of decimal places are said to be more **precise** than those to a whole number

Accuracy

- A measurement is considered **accurate** if it is close to the true value
 - Another way to describe this concept is if the **systematic error** of a measurement is **small**, then that measurement can be said to be **accurate**
- The accuracy can be **increased by repeating measurements** and finding a mean of the results
- Repeating measurements also helps to identify anomalies that can be omitted from the final results

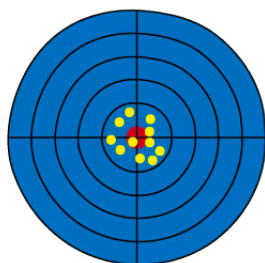

ACCURATE
AND PRECISE

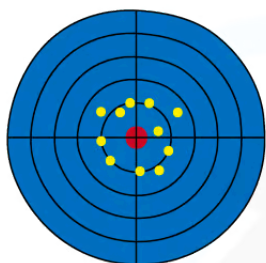

ACCURATE BUT
NOT PRECISE

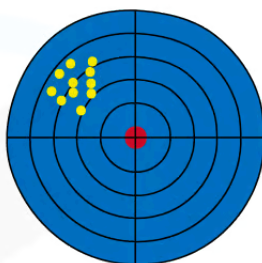

PRECISE BUT
NOT ACCURATE

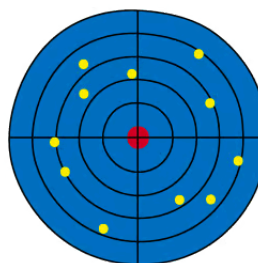

NEITHER ACCURATE
NOR PRECISE

Copyright © Save My Exams. All Rights Reserved

The difference between precise and accurate results

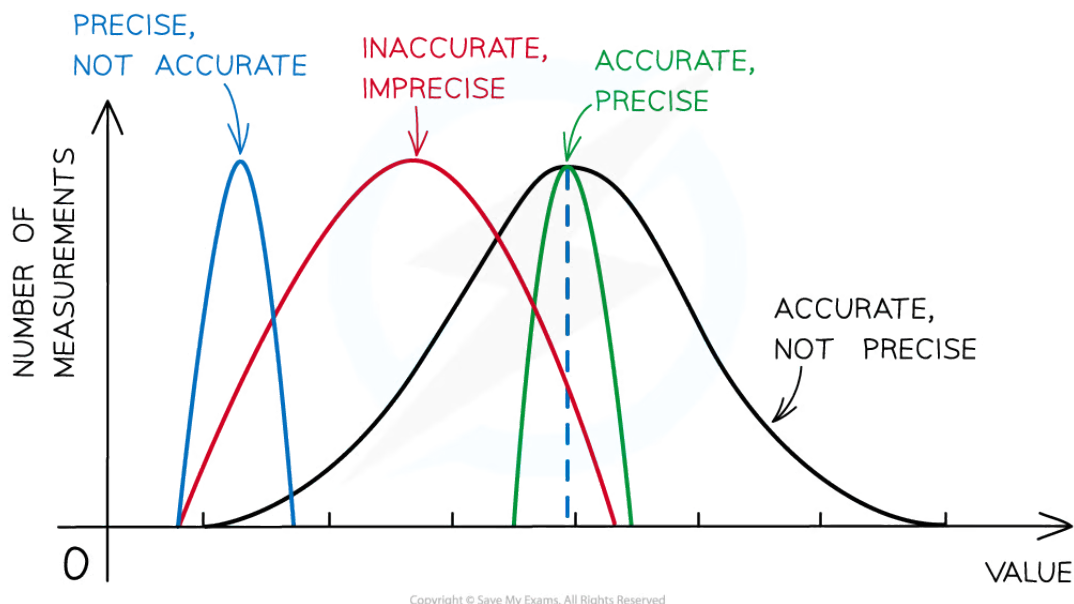

Representing precision and accuracy on a graph

Reliability

- Reliability is defined as
A measure of the ability of an experimental procedure to produce the expected results when using the same method and equipment
- A reliable **experiment** is one which produces consistent results when repeated many times
- Similarly, a reliable **measurement** is one which can be reproduced consistently when measured repeatedly
- When thinking about the reliability of an experiment, a **good question** to ask is
 - Would similar conclusions be reached if someone repeated this experiment?

Validity

- The validity of an experiment relates to the experimental method and the appropriate choice of variables
- Validity is defined as
A measure of the suitability of an experimental procedure to measure what it is intended to measure
- It is essential that any variables that may affect the outcome of an experiment are **identified** and **controlled** in order for the results to be **valid**
- For example, when using Charles' law to determine absolute zero, **pressure** must be kept constant

- When thinking about the validity of an experiment, a **good question** to ask is
 - How relevant is this experiment to my original research question?



Your notes



Your notes

Calculating Uncertainties

Calculating Uncertainties

- There is always a degree of uncertainty when measurements are taken; the uncertainty can be thought of as the difference between the **actual** reading taken (caused by the equipment or techniques used) and the **true value**
- Uncertainties are **not** the same as errors
 - Errors can be thought of as issues with equipment or methodology that cause a reading to be different from the true value
 - The uncertainty is a range of values around a measurement within which the true value is expected to lie, and is an **estimate**
- For example, if the true value of the mass of a box is 950 g, but a systematic error with a balance gives an actual reading of 952 g, the uncertainty is ± 2 g
- These uncertainties can be represented in a number of ways:
 - Absolute Uncertainty:** where uncertainty is given as a fixed quantity
 - Fractional Uncertainty:** where uncertainty is given as a fraction of the measurement
 - Percentage Uncertainty:** where uncertainty is given as a percentage of the measurement

$$\text{percentage uncertainty} = \frac{\text{uncertainty}}{\text{measured value}} \times 100\%$$

- To find uncertainties in different situations:
 - The uncertainty in a reading:** \pm half the smallest division
 - The uncertainty in a measurement:** at least ± 1 smallest division
 - The uncertainty in repeated data:** half the range i.e. $\pm \frac{1}{2}$ (largest - smallest value)
 - The uncertainty in digital readings:** \pm the last significant digit unless otherwise quoted
 - The uncertainty in the natural log of a value:** absolute uncertainty in $\ln(x) = \frac{\text{uncertainty in } x}{x}$

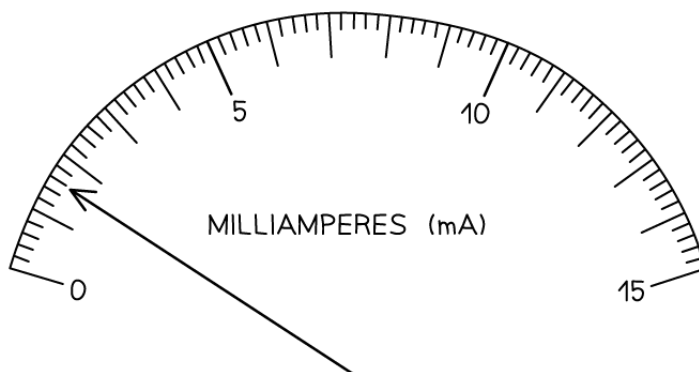

SMALLEST DIVISION = 0.2 mA

READING (I) = 1.6 mA

$$\text{ABSOLUTE UNCERTAINTY } (\Delta I) = \frac{1}{2} \times 0.2 \text{ mA} = 0.1 \text{ mA}$$

$$I = 1.6 \pm 0.1 \text{ mA}$$

$$\text{FRACTIONAL UNCERTAINTY} = \frac{\text{UNCERTAINTY}}{\text{VALUE}} = \frac{0.1}{1.6} = \frac{1}{16}$$

$$I = 1.6 \pm \frac{1}{16} \text{ mA}$$

$$\text{PERCENTAGE UNCERTAINTY } (\%) = \frac{\text{UNCERTAINTY}}{\text{VALUE}} \times 100 = \frac{0.1}{1.6} \times 100 = 6.2\%$$

$$I = 1.6 \pm 6.2\% \text{ mA}$$

Copyright © Save My Exams. All Rights Reserved

How to calculate absolute, fractional and percentage uncertainty

- Always make sure your absolute or percentage uncertainty is to the same number of **significant figures** as the reading

Combining Uncertainties

- When combining uncertainties, the rules are as follows:



Your notes

Operation	Example	Propagation Rule
Addition & Subtraction	$y = a \pm b$	$\Delta y = \Delta a + \Delta b$ The sum of the absolute uncertainties
Multiplication & Division	$y = a \times b$ or $y = \frac{a}{b}$	$\frac{\Delta y}{y} = \frac{\Delta a}{a} + \frac{\Delta b}{b}$ The sum of the fractional uncertainties
Power	$y = a^{\pm n}$	$\frac{\Delta y}{y} = n \left(\frac{\Delta a}{a} \right)$ The magnitude of n times the fractional uncertainty

Adding / Subtracting Data

- **Add** together the absolute uncertainties



Your notes

ADDING / SUBTRACTING DATA

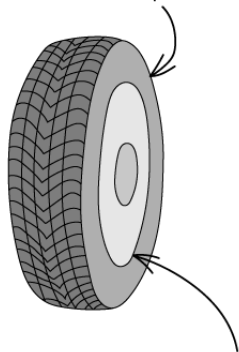
DIAMETER OF TYRE (d_1) = 55.0 ± 0.5 cmDIAMETER OF INNER TYRE (d_2) = 21.0 ± 0.7 cmDIFFERENCE IN DIAMETERS ($d_1 - d_2$) = $55.0 - 21.0 = 34.0$ cmUNCERTAINTY IN DIFFERENCE = $\pm(0.5 + 0.7) = \pm 1.2$ cm $d_1 - d_2 = 34.0 \pm 1.2$ cm**Multiplying / Dividing Data**

- **Add** the percentage or fractional uncertainties

MULTIPLYING / DIVIDING DATA



Your notes

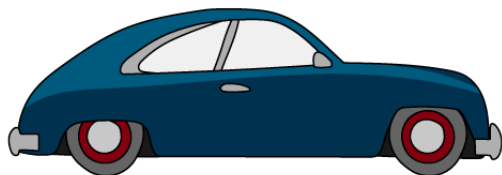

$$\text{DISTANCE} = 50.0 \pm 0.1 \text{ m}$$

$$\text{TIME} = 5.00 \pm 0.05 \text{ s}$$

$$\text{SPEED (v)} = \frac{\text{DISTANCE (s)}}{\text{TIME (t)}}$$

$$v = \frac{50.0}{5.0} = 10.0 \text{ ms}^{-1}$$

$$\frac{\Delta v}{v} = \frac{\Delta s}{s} + \frac{\Delta t}{t} = \frac{0.1}{50.0} + \frac{0.05}{5.00} = 0.002 + 0.01 = 0.012$$

$$\text{ABSOLUTE UNCERTAINTY } (\Delta v) = 10.0 \times 0.012 = \pm 0.12 \text{ ms}^{-1}$$

$$v = 10.0 \pm 0.12 \text{ ms}^{-1}$$

Copyright © Save My Exams. All Rights Reserved

Raising to a Power

- **Multiply** the percentage uncertainty by the power

RAISING TO A POWER

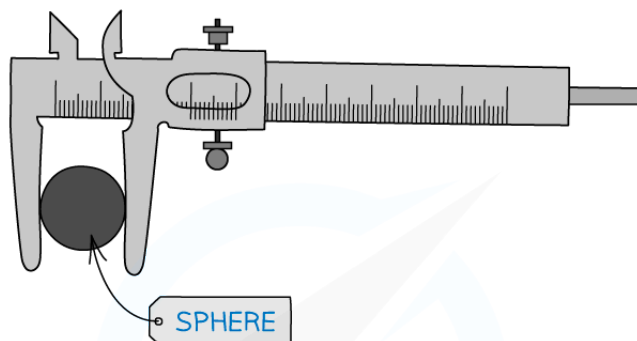

$$V = \frac{4}{3} \pi r^3$$

$$r = 2.50 \pm 0.02 \text{ cm}$$

$$V = \frac{4}{3} \pi (2.50)^3 = 65.5 \text{ cm}^3$$

$$\frac{\Delta V}{V} = 3 \times \frac{\Delta r}{r} = 3 \times \frac{0.02}{2.50} = 0.024$$

$$\text{ABSOLUTELY UNCERTAINTY } (\Delta V) = 65.5 \times 0.024 = 1.57 \text{ cm}^3$$

$$\text{PERCENTAGE UNCERTAINTY } (\% \Delta V) = 100 \times 0.024 = 2.4 \%$$

Copyright © Save My Exams. All Rights Reserved

Examiner Tip

Remember:

- Absolute uncertainties (denoted by Δ) have the same units as the quantity
- Percentage uncertainties have no units
- The uncertainty in constants, such as π , is taken to be zero

Uncertainties in trigonometric and logarithmic functions will not be tested in the exam, so just remember these rules and you'll be fine!



Your notes

Determining Uncertainties from Graphs

Determining Uncertainties from Graphs

- The uncertainty in a measurement can be shown on a graph as an **error bar**
- This bar is drawn above and below the point (or from side to side) and shows the **uncertainty** in that measurement
- Error bars are plotted on graphs to show the **absolute uncertainty** of values plotted

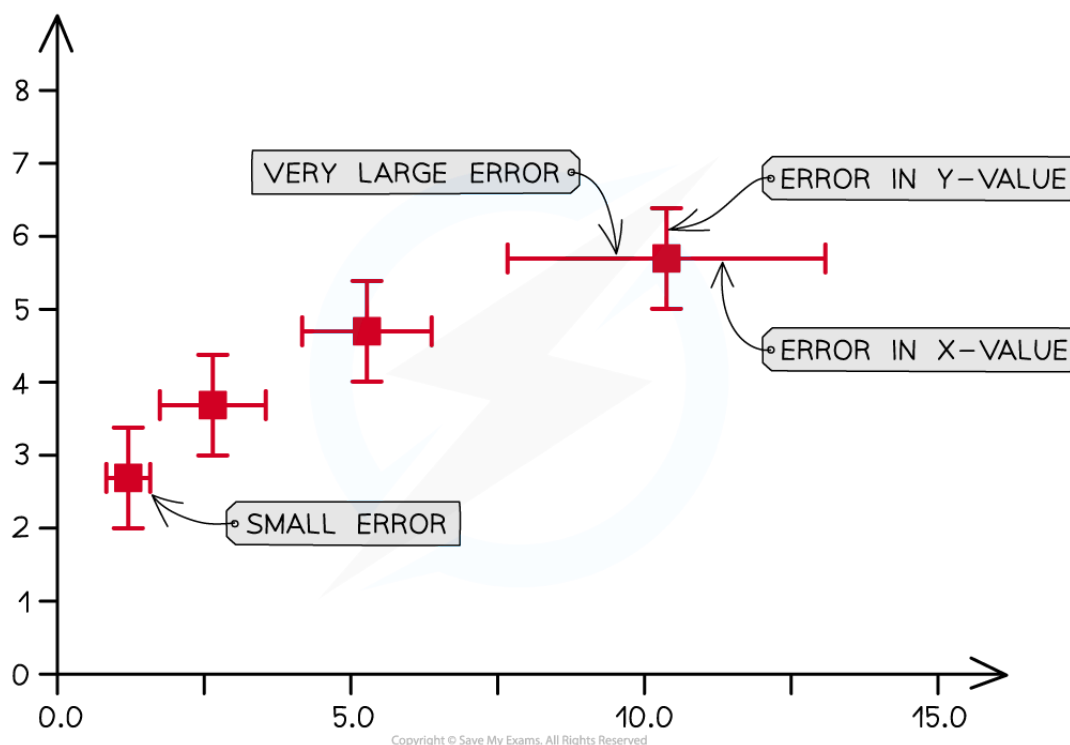

Representing error bars on a graph

- To calculate the **uncertainty in a gradient**, two lines of best fit should be drawn on the graph:
 - The 'best' line of best fit, which passes as **close to the points as possible**
 - The 'worst' line of best fit, either the **steepest possible** or the **shallowest possible** line which fits within all the error bars

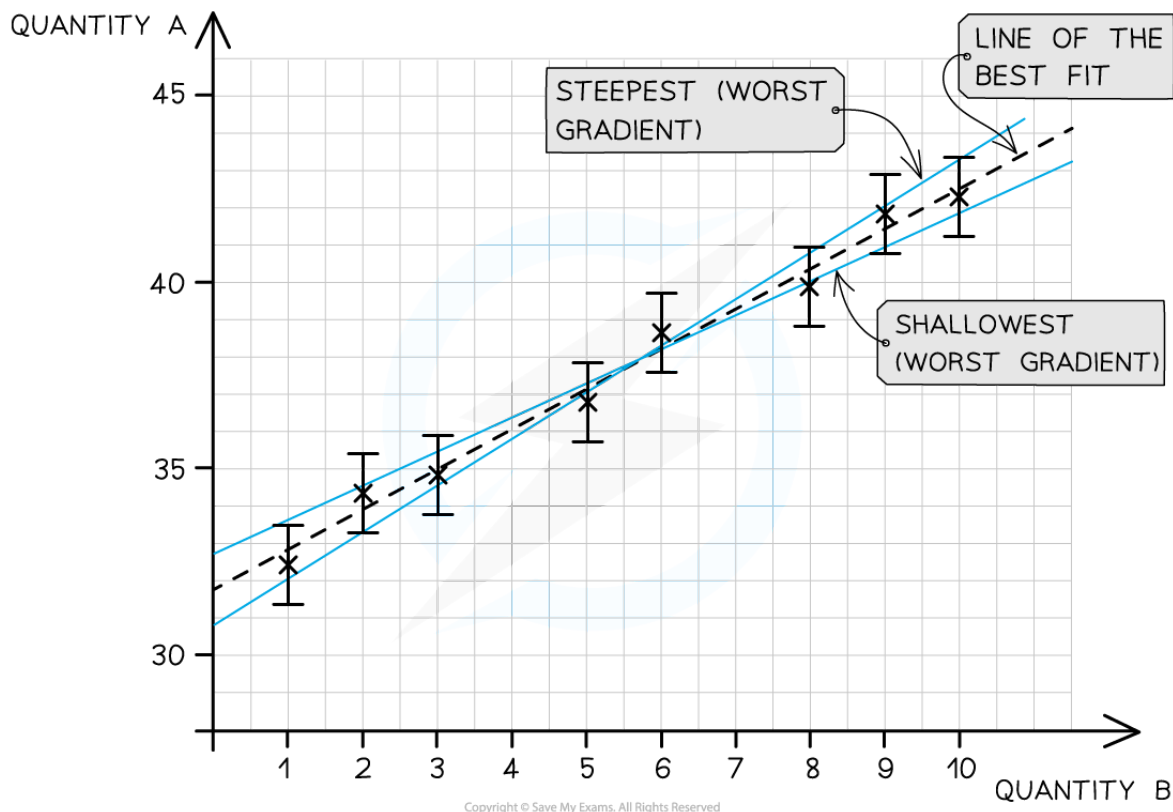

The line of best fit passes as close as possible to all the points. The steepest and shallowest lines are known as the worst fit

- The percentage uncertainty in the **gradient** can be found using the magnitude of the 'best' and 'worst' gradients:

$$\text{percentage uncertainty} = \frac{\text{best gradient} - \text{worst gradient}}{\text{best gradient}} \times 100\%$$

- Either the steepest or shallowest line of best fit may have the 'worst' gradient on a case-by-case basis.
 - The 'worst' gradient will be the one with the **greatest difference** in magnitude from the 'best' line of best fit.
 - The equation **above** is for the case where the 'worst' gradient is the **shallowest**.
 - If the 'worst' gradient is the **steepest**, then the 'worst' gradient should be **subtracted** from the 'best' gradient and **then** divided by the best gradient and multiplied by 100
- Alternatively, the **average** of the two maximum and minimum lines can be used to calculate the percentage uncertainty:

$$\text{percentage uncertainty} = \frac{\text{max. gradient} - \text{min. gradient}}{2} \times 100\%$$

- The percentage uncertainty in the **y-intercept** can be found using:

$$\text{percentage uncertainty} = \frac{\text{best } y \text{ intercept} - \text{worst } y \text{ intercept}}{\text{best } y \text{ intercept}} \times 100\%$$

$$\text{percentage uncertainty} = \frac{\text{max. } y \text{ intercept} - \text{min. } y \text{ intercept}}{2} \times 100\%$$



Your notes

Percentage Difference

- The percentage difference gives an indication of how close the **experimental value** achieved from an experiment is to the **accepted value**
 - It is **not** a percentage uncertainty
- The percentage difference is defined by the equation:

$$\text{percentage difference} = \frac{\text{experimental value} - \text{accepted value}}{\text{accepted value}} \times 100\%$$

- The experimental value is sometimes referred to as the 'measured' value
- The accepted value is sometimes referred to as the 'true' value
 - This may be labelled on a component such as the capacitance of a capacitor or the resistance of a resistor
 - Or, from a reputable source such as a peer-reviewed data booklet
- For example, the acceleration due to gravity g is known to be 9.81 m s^{-2} . This is its **accepted value**
 - From an experiment, the value of g may be found to be 10.35 m s^{-2}
 - Its **percentage difference** would therefore be 5.5%
- The **smaller** the percentage difference, the more **accurate** the results of the experiment



Your notes

Worked example

On the axes provided, plot the graph for the following data and draw error bars and lines of best and worst fit.

Force / N	10	20	30	40	50	60	70	80
Extension / mm	8.5 ± 1	11 ± 0.5	15 ± 1	15 ± 2	20 ± 1.5	19.5 ± 2	22 ± 0.5	26 ± 1

Copyright © Save My Exams. All Rights Reserved

Find the percentage uncertainty in the gradient from your graph.

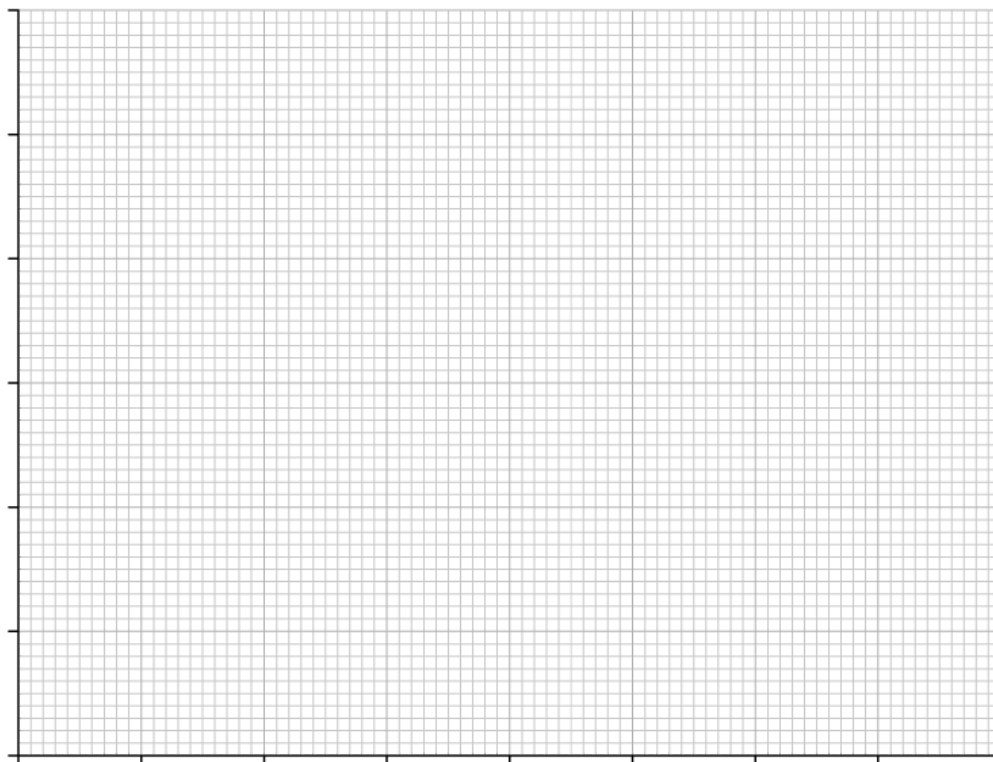

Answer:

Step 1: Draw sensible scales on the axes and plot the data



Your notes

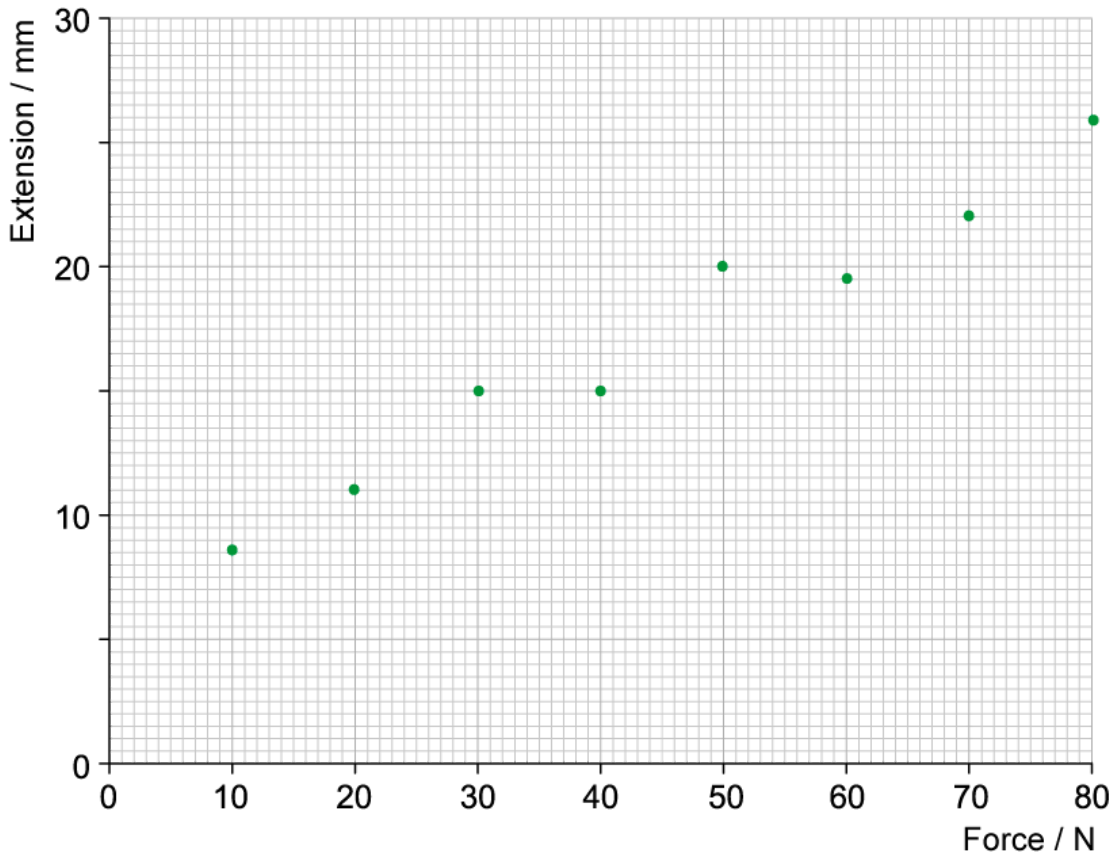

Step 2: Draw the errors bars for each point



Your notes

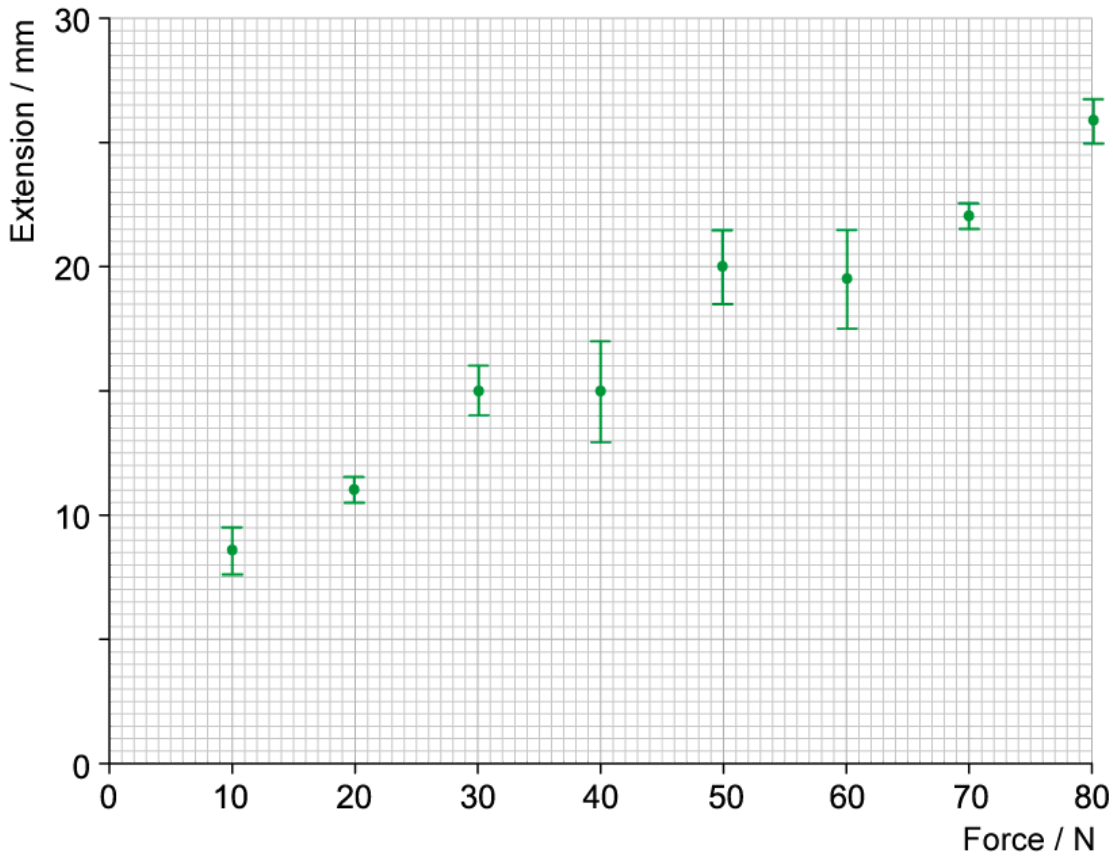

Step 3: Draw the line of best fit



Your notes

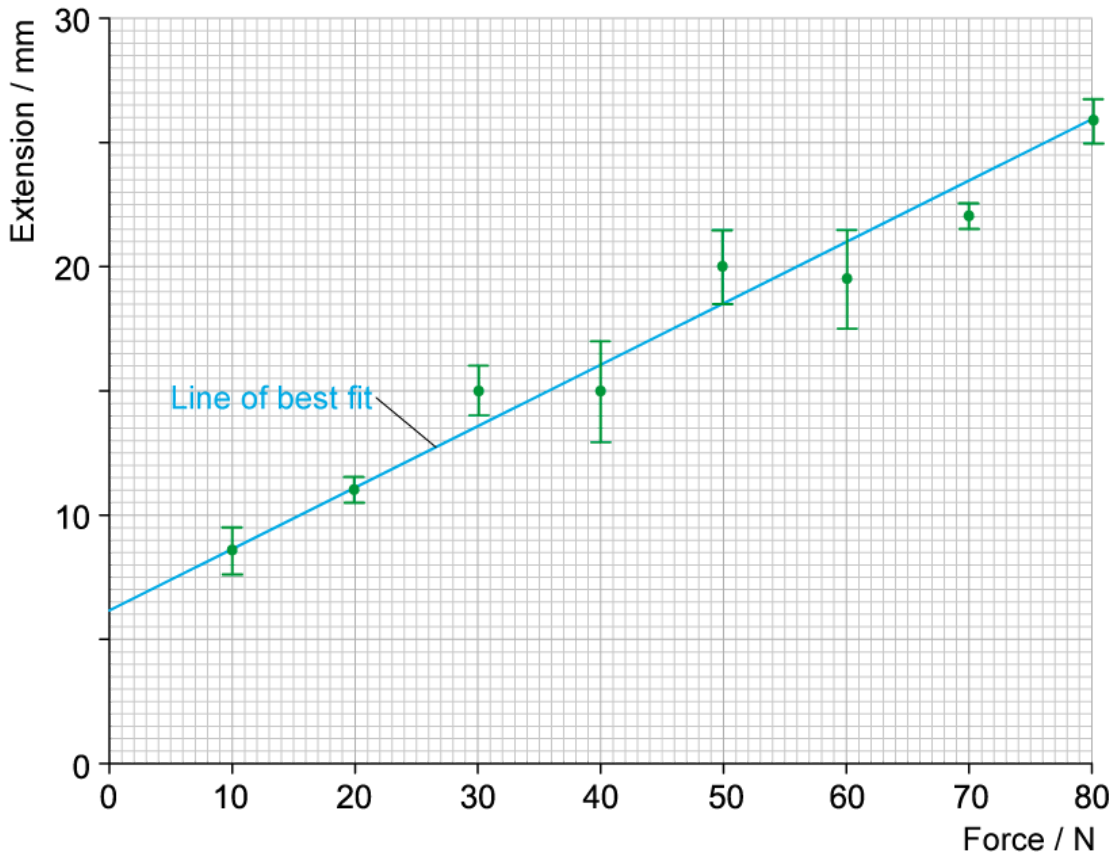

Step 4: Draw the line of worst fit



Your notes

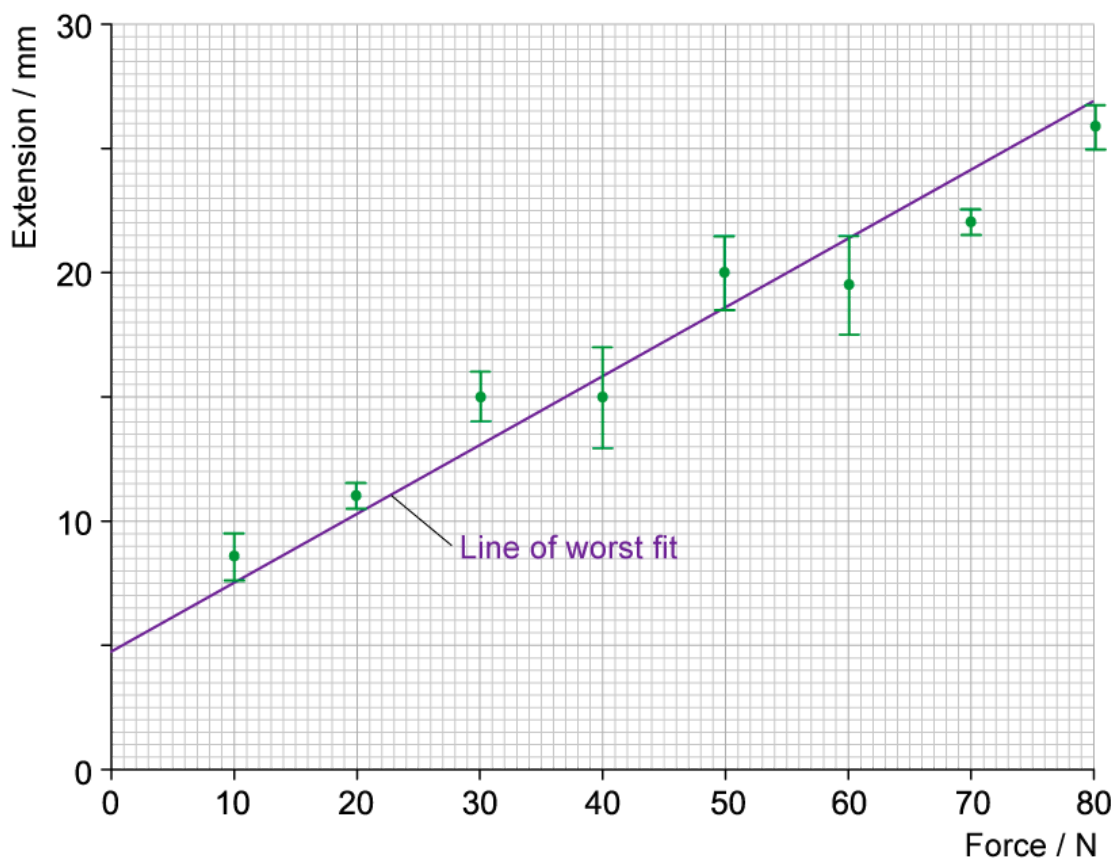

Step 5: Work out the gradient of each line and calculate the percentage uncertainty



Your notes

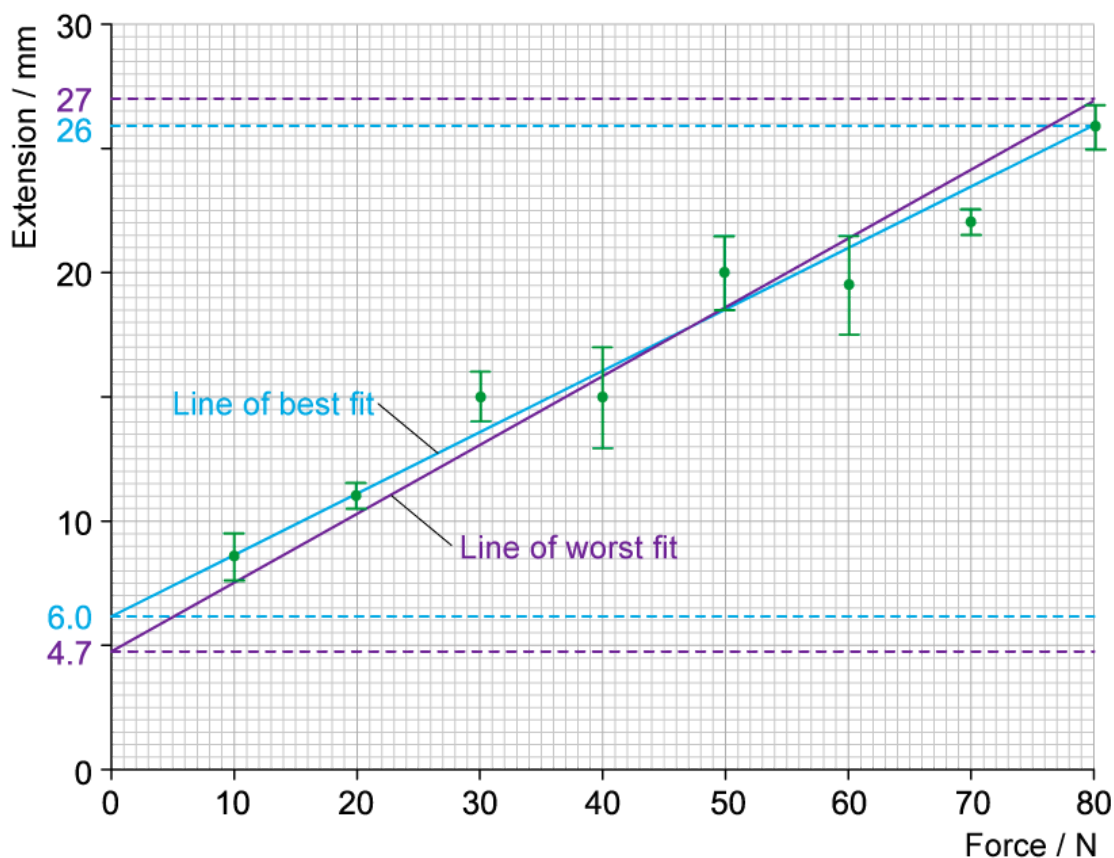

- best gradient = $\frac{\Delta y}{\Delta x} = \frac{26 - 6}{80 - 0} = 0.25$
- worst gradient = $\frac{\Delta y}{\Delta x} = \frac{27 - 4.7}{80 - 0} = 0.28$
- % uncertainty = $\frac{0.28 - 0.25}{0.25} \times 100\% = 12\%$

Examiner Tip

A common misconception is that error bars need to all be the same size. In physics, this is not the case and each data point can have different error bar sizes as they have different uncertainties.