

Structured Questions

Current & Circuits

Circuit Diagrams / Electric Current / Electric Potential Difference / Electrical Conductors & Insulators / Electric Resistance / Electrical Resistivity / I-V Characteristics / Series & Parallel Circuits / Electrical Power / Sources of Electrical Energy / Electromotive Force & Internal Resistance / Variable Resistance

Easy (11 questions)	/116
Medium (11 questions)	/89
Hard (9 questions)	/81
Total Marks	/286

Scan here to return to the course
or visit [savemyexams.com](https://www.savemyexams.com)



Easy Questions

1 (a) Define the coulomb.

.....
.....
(2 marks)

(b) A charge of 60×10^{-6} C flows through a given section of a conductor in 140×10^{-3} s. Calculate the electric current, stating the final answer in mA.

.....
.....
(2 marks)

(c) Use words from the list below to complete the description of the movement of charge carriers in a conductor.

- | | | |
|------------------------|--------------------|-----------------------|
| average current | delocalised | electric force |
| electric field | randomly | drift |

The charge carriers in a metal conductor are electrons.

Normally the electrons move in all directions, but if a potential difference is applied between two points on the conductor, then an is created.

This causes an to act on the charge carriers, causing them to along the conductor in a resultant direction.

Therefore we can say that a steady flows through the conductor.

.....
.....

(4 marks)

2 (a) Define electrical current.

(2 marks)

(b) Define potential difference.

(i) State the definition in words.

[1]

(ii) State the equation, defining all terms.

[2]

(3 marks)

3 (a) In circuit building a set of agreed symbols is in use worldwide to represent components.

For each description below, write the name and draw the correct symbol which would be used in a circuit diagram.

(i) A resistor whose resistance depends on the light intensity. [2]

(ii) A component with zero resistance which measures the current in the circuit. [2]

(iii) The component which is used to convert ac current to dc current; it also allows current to flow in only one direction. [2]

.....

.....

.....

.....

.....

.....

(6 marks)

(b) In each case select the word to correctly describe an ammeter.

- In a circuit the **current/voltage/resistance** is measured using an ammeter, which is always connected in **series/parallel** within a circuit.
- An ideal ammeter should have **very high/zero** resistance. This prevents the ammeter taking any energy from the **electrons/positive ions** flowing through it.
- If the electrons transferred their **electricity/energy/motion** to the ammeter this would change the circuit by **reducing/increasing** the value of the current it is meant to measure.

(3 marks)

(c) A charge of 15.0 C passes through a resistor at a constant rate in 60 s. The potential difference across the resistor is 2.0 V.

Calculate the resistance R of the resistor.

(3 marks)

(d) The resistance of a wire is affected by factors including the resistivity of the material it is made from.

(i) Define resistivity.

[2]

(ii) State two other factors apart from temperature which affects the resistance of a wire. For each one identify whether the relationship is directly or inversely proportional to resistance.

[2]

(4 marks)

- 4 (a)** A student is building a circuit using three resistors, each with a value of 5.0Ω . The student arranges the resistors first in series and then in parallel, as shown.

Determine the total resistance in each case.

- (i) Three 5.0Ω resistors in series

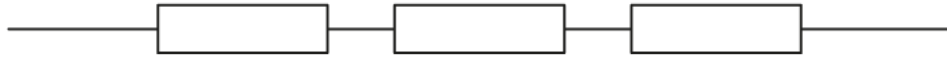

[2]

- (ii) Three 5.0Ω resistors in parallel

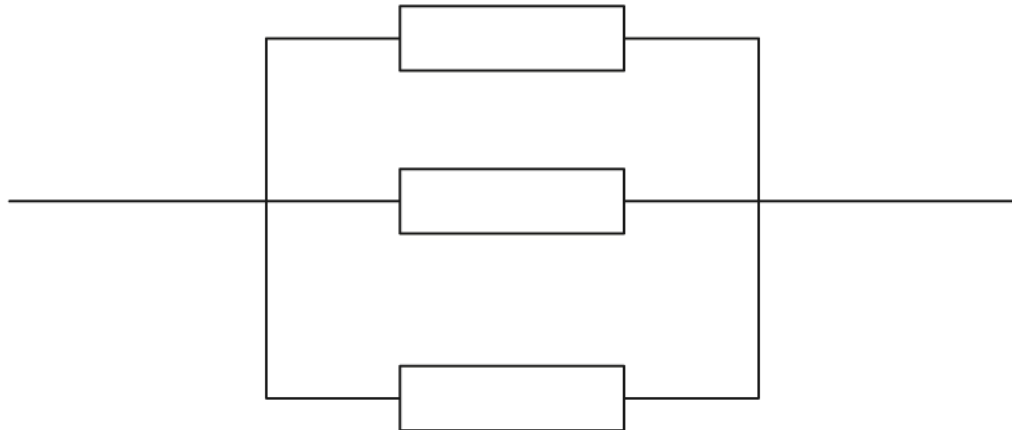

[2]

(4 marks)

- (b)** The student arranges the identical 5.0Ω resistors so that they are in a combination of series and parallel as shown.

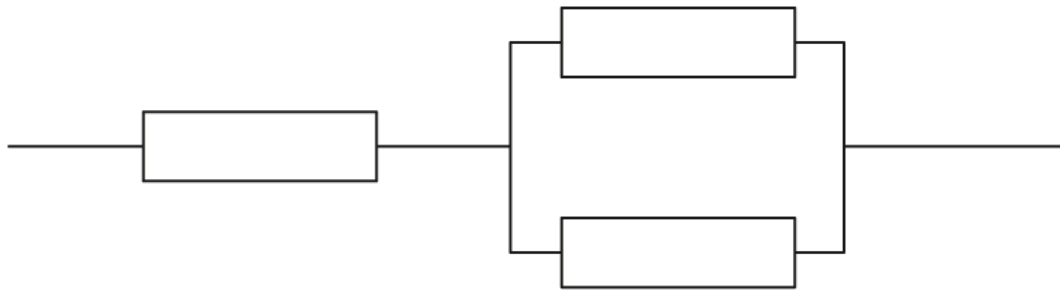

Calculate the new combined resistance.

(3 marks)

- (c) An electrically-conducting wire is made from copper. Copper has resistivity $\rho = 1.7 \times 10^{-8} \Omega \text{ m}$.

The wire has diameter $d = 2.0 \text{ mm}$ and length $L = 20 \text{ mm}$ as shown.



For the wire calculate

- (i) The cross-sectional area of the wire [2]
- (ii) The resistance of the wire [2]

(4 marks)

- (d) A student investigating the resistivity of a sample of wire has plotted a graph of resistance against length as shown.

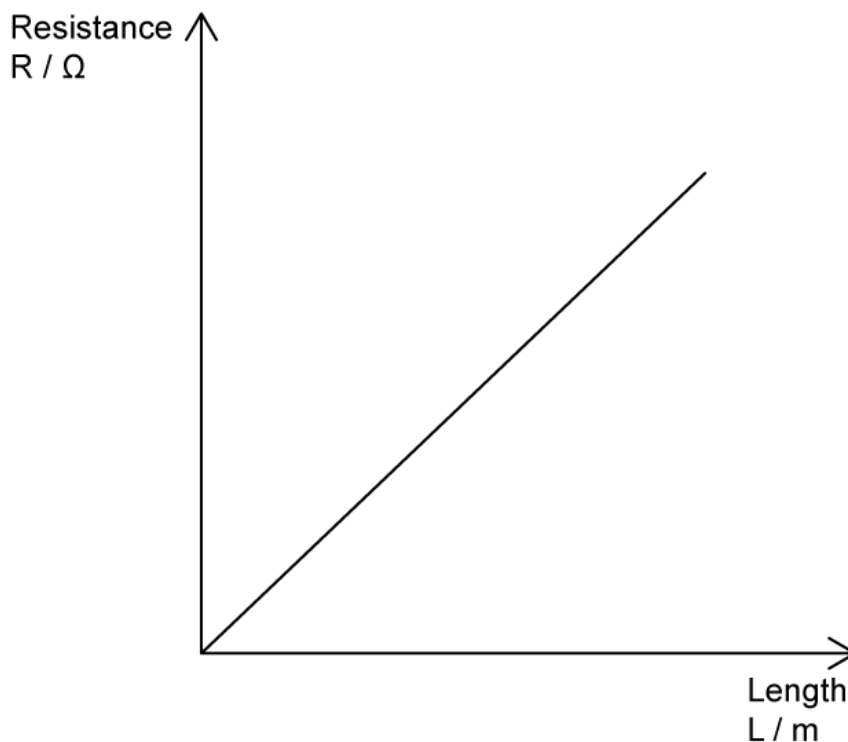

Explain how the graph can be used to determine the resistivity of the wire.

(3 marks)

5 (a) Define resistance.

(2 marks)

(b) Write an expression for the current shown in the following section of a circuit

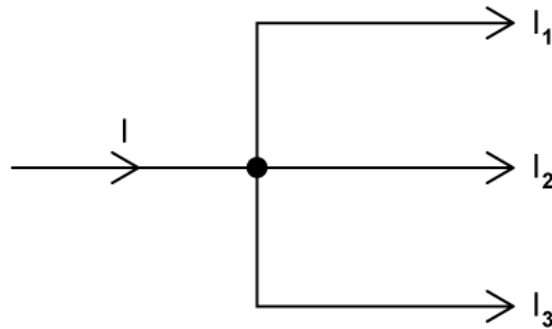

(1 mark)

(c) For the circuit shown determine the values on the ammeters A_1 , A_2 and A_3 .

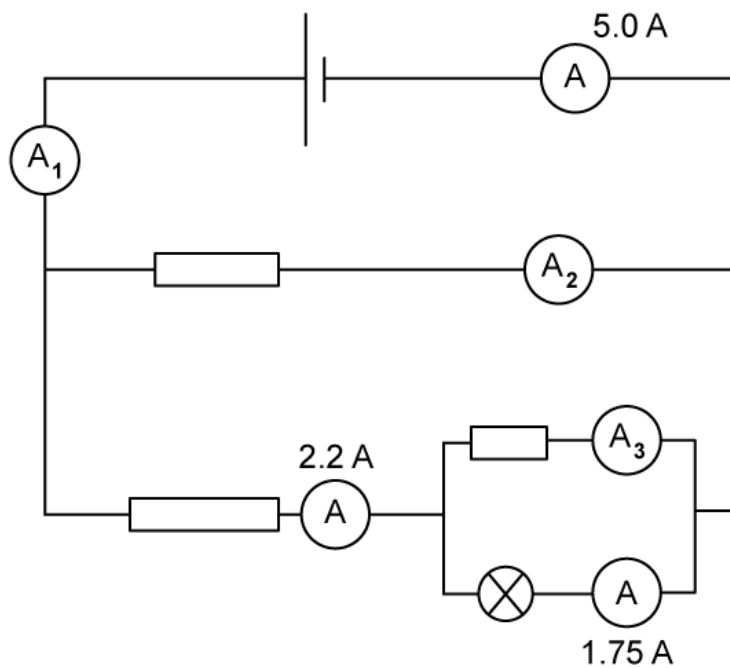

(3 marks)

6 (a) The graph shown represents current and potential difference for an Ohmic resistor.

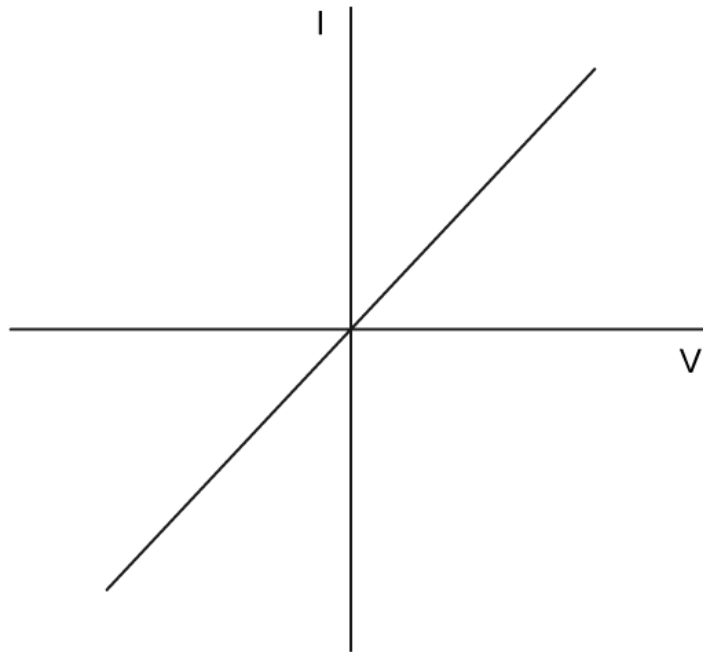

State the features of the graph which show that the resistor obeys Ohm's Law.

.....

.....

(2 marks)

(b) A student investigating the I-V characteristics of various components plots the graph shown.

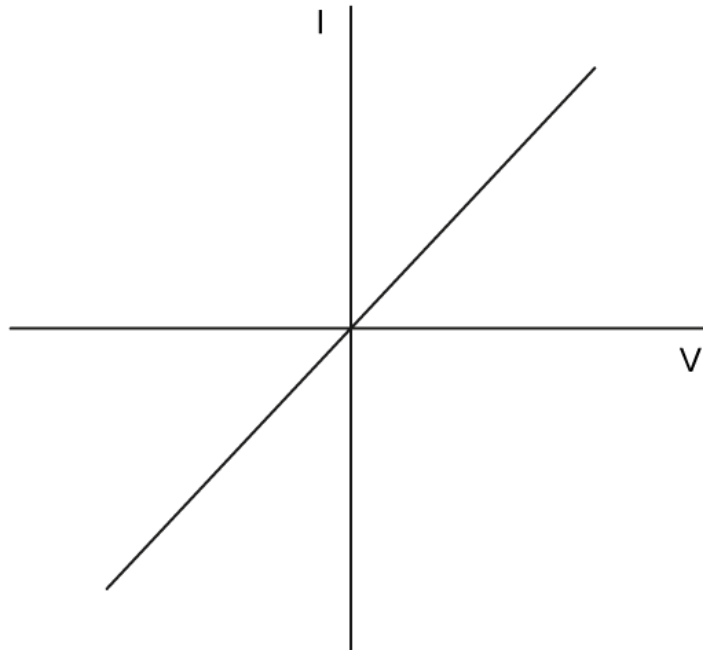

Outline how to find the resistance of the component from the graph.

.....

.....

.....

(3 marks)

- (c)** The graph shown represents the I-V characteristics of a non-Ohmic resistor such as a lamp.

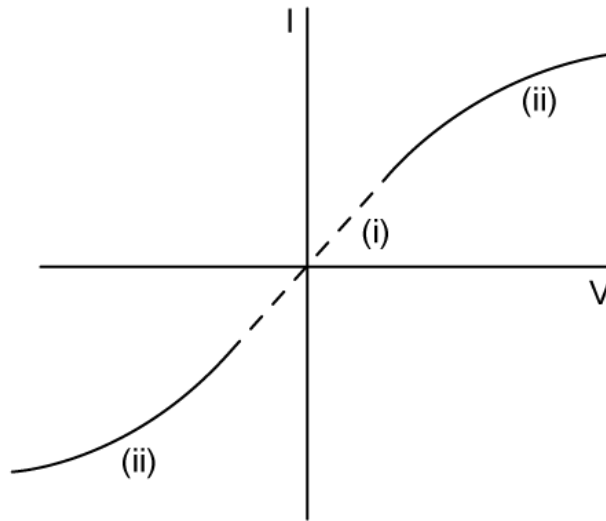

The graph consists of three distinct parts.

(i) For the section labelled (i) outline the behaviour of the resistor.

[2]

(ii) For the two similar sections labelled (ii) outline the behaviour of the resistor.

[3]

.....

.....

.....

.....

.....

(5 marks)

(d) Heating is typically seen in electrical components and must be accounted for so that they operate safely and efficiently.

State two factors which increase the amount of heat output.

.....

.....

(2 marks)

7 (a) For the series circuit shown, calculate

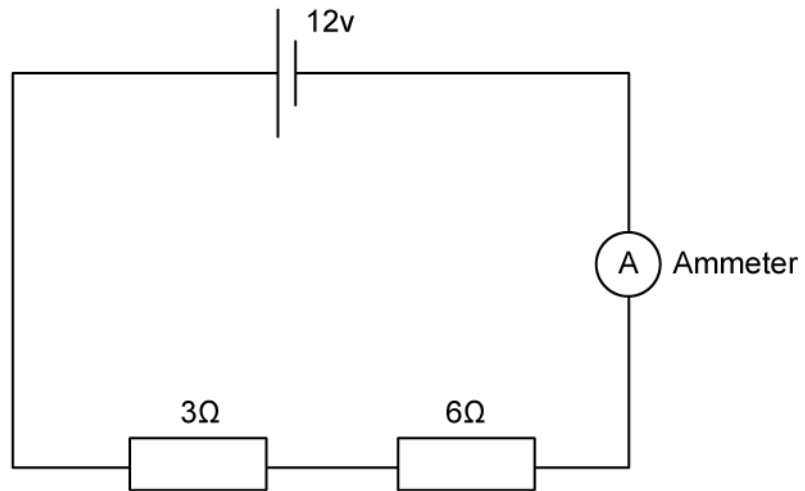

(i) Total resistance.

[2]

(ii) Current measured by the ammeter

[2]

.....

.....

.....

.....

(4 marks)

(b) For the parallel circuit shown, calculate

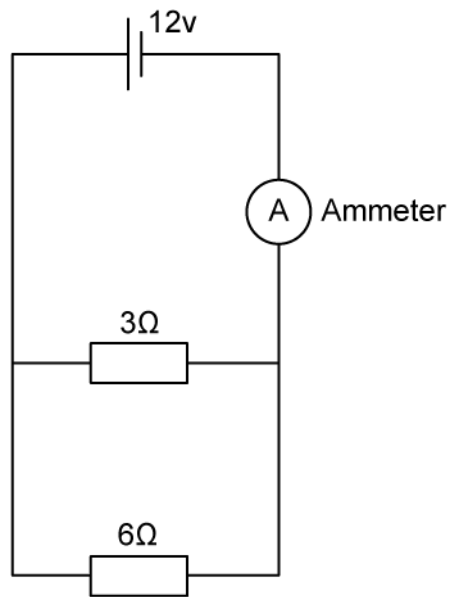

(i) Total resistance.

[2]

(ii) Current measured by the ammeter

[2]

.....

.....

.....

.....

(4 marks)

- 8 (a) Chemical cells used in circuits can be divided into two groups, rechargeable or non-rechargeable cells.

Give an example of a non-rechargeable cell.

.....
.....
(1 mark)

- (b) Give an example of a rechargeable cell and state a device it might be used in.

.....
.....
(2 marks)

- (c) For the following descriptions of the functions of rechargeable or non-rechargeable cells, choose the correct words from each pair in bold to complete the sentences.

During normal operation of a non-rechargeable cell, the electrons flow from the **negative/positive** plate of the cell, around the circuit, to the **negative/positive** plate of the cell.

When charging a rechargeable cell, the electrons are forced from the **negative/positive** plate to the **negative/positive** plate by an external current.

.....
.....
(2 marks)

- (d) Lithium cells are widely used and have allowed for a revolution in the manufacture of portable electronics. However there are concerns with reliance on lithium as a material for making cells.

Outline two concerns with the use of lithium in cells.

.....
.....
(2 marks)

9 (a) The electromotive force, ε is defined by the equation

$$\varepsilon = I(R + r)$$

Define the following variables and state an appropriate unit for each.

- (i) I [1]
- (ii) R [1]
- (iii) r [1]

.....

.....

.....

(3 marks)

(b) The circuit shown includes a cell with internal resistance and a load resistor.

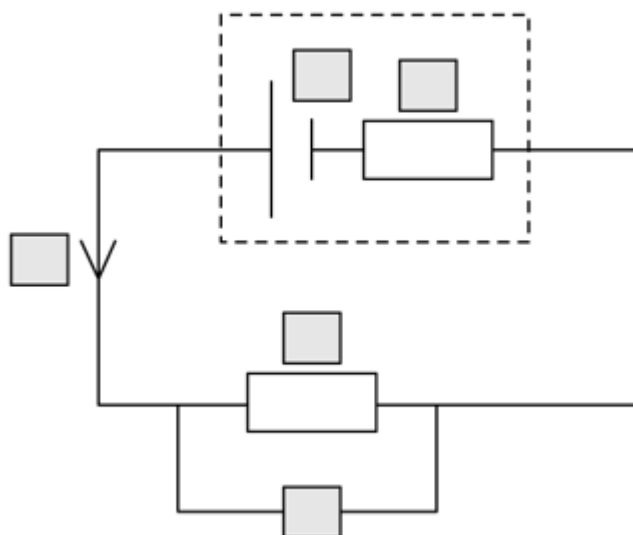

Complete the labels on the components using each of the following variables once only.

ε I r R V

(5 marks)

(c) A current of 0.6 mA flows through the circuit in part (a) and the resistor has a resistance of 2.5 kΩ.

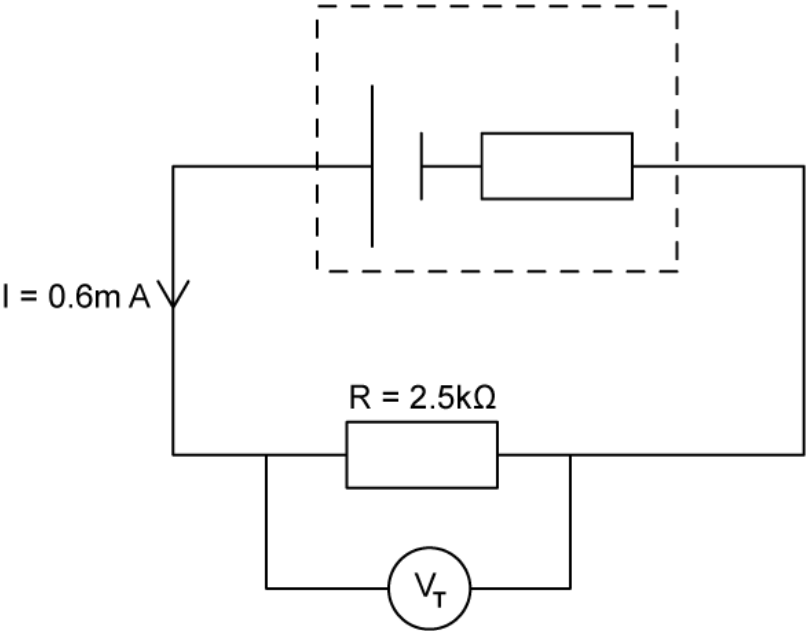

Calculate the terminal potential difference V_T of the circuit.

(3 marks)

(d) The internal resistance of the cell is $1.3 \text{ k}\Omega$.

Calculate the emf of the cell.

(3 marks)

10 (a) Explain what is meant by the electromotive force of a cell and state the units.

(4 marks)

(b) Define the internal resistance of a cell.

(1 mark)

(c) In the circuit shown a high resistance voltmeter is used to measure the potential difference across the terminals of a battery.

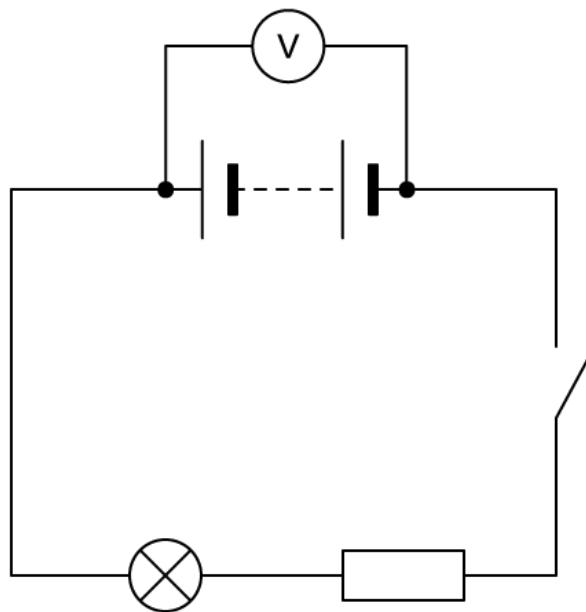

The switch is closed.

(i) State how the voltmeter reading changes.

[1]

(ii) Explain what property of the battery causes this change.

[1]

(2 marks)

(d) Explain why the voltmeter reading changes when the switch is closed.

(1 mark)

11 (a) The circuit shown is used to test a battery of four identical cells each with emf $\varepsilon = 0.70 \text{ V}$.

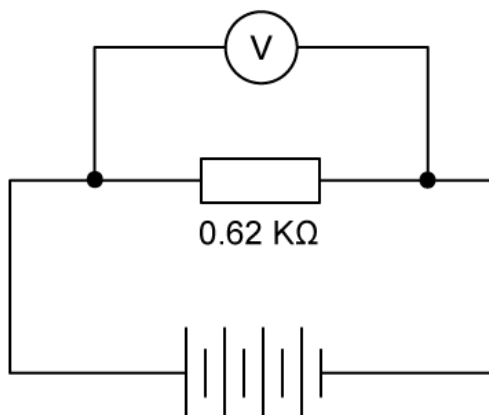

A fixed resistor with $R = 0.62 \text{ k}\Omega$ is connected in series with the cell. A current $I = 4.50 \text{ mA}$ travels through the circuit.

For this circuit

- (i) Calculate the emf of the battery. [2]
- (ii) Calculate the internal resistance of the battery. [3]
- (iii) State an appropriate unit for your answer. [1]

.....

.....

.....

.....

.....

.....

.....

(6 marks)

(b) For the circuit in part (a), calculate the internal resistance of one cell.

.....

(c) As cells are used they discharge their voltage, according to a curve as shown.

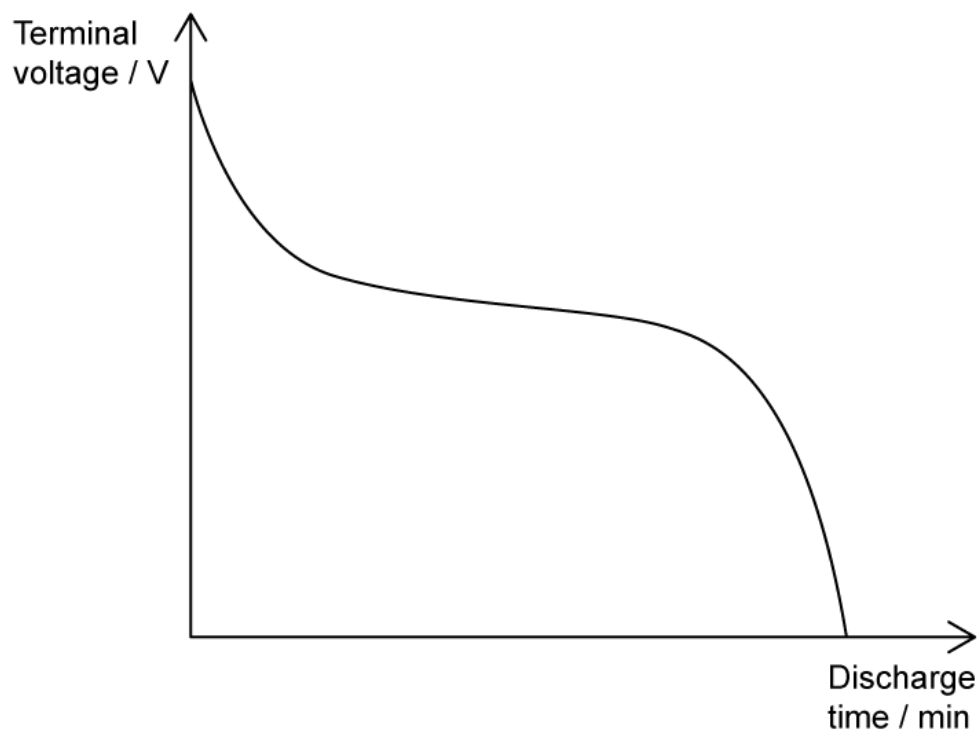

To describe the graph, choose the correct word from each pair.

- When a cell is discharging, it **will/will not** discharge a constant amount of voltage.
- When the cell is new the initial high voltage will begin to discharge **slowly/fairly quickly**.
- For most of the life of the cell it discharges **slowly/fairly quickly**.
- Finally, as the cell reaches the end of its life the voltage is discharged **slowly/fairly quickly**.

(4 marks)

- (d)** The graph in part (c) represents a 1.5 V AA battery discharging over time. The battery is connected so that the circuit draws a current of 2.0 A.

Using the graph from part (c), add discharge curves for two identical cells which are drawing different currents. Label your lines (i) and (ii).

(i) Current, $I = 1.0 \text{ A}$

[3]

(ii) Current, $I = 4.0 \text{ A}$

[3]

(6 marks)

Medium Questions

1 (a) In a circuit, a current of 2.0 A flows through a resistor for 90 minutes.

Determine the number of electrons that pass a point in the resistor this time.

(3 marks)

(b) The current in (a) flows across a potential difference of 12 V.

Using your answer to (a), calculate the total energy transferred in the circuit.

(2 marks)

(c) When a copper wire is exposed to a potential difference, a current is detected in it.

Explain, with reference to charge carriers, why there is a current detected in the wire.

(2 marks)

2 A student is investigating the electrical resistivity of a thin film of carbon.

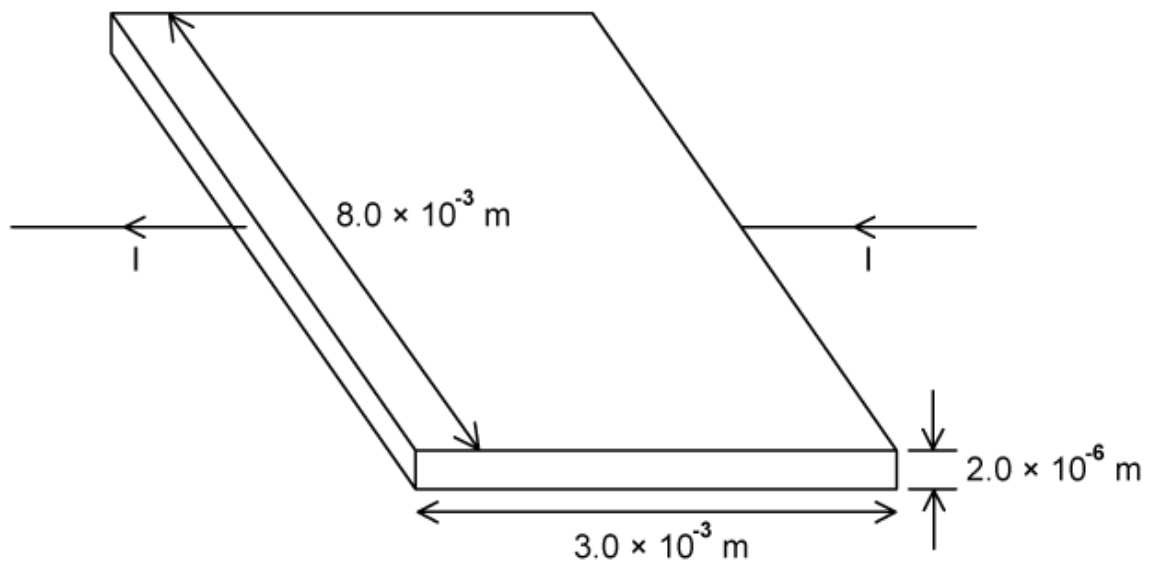

Calculate the current which passes through the carbon film when a potential difference of 2.5 mV is applied across it.

The resistivity of carbon is $4.0 \times 10^{-5} \Omega \text{ m}$.

(3 marks)

3 (a) A current $I = 10 \text{ A}$ flows through a network of six resistors as shown.

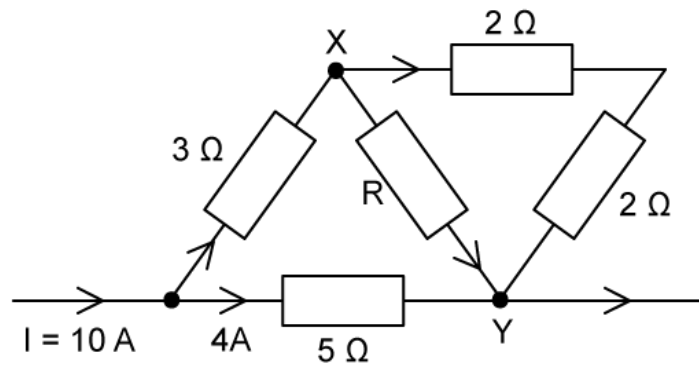

The potential difference across the line XY is 8 V.

Calculate the value of the unknown resistance R .

(4 marks)

(b) Another network, comprised of four identical resistors each of resistance 2Ω , is connected to a 6 V battery with negligible internal resistance.

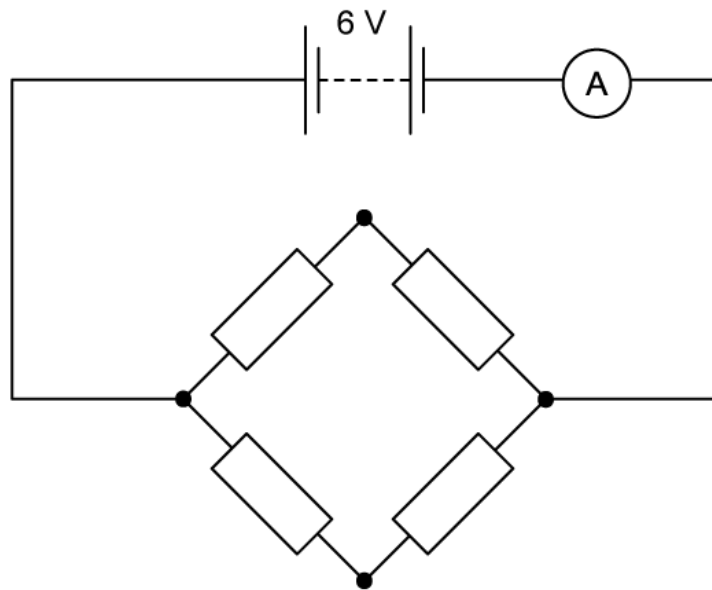

Determine the reading on the ammeter.

.....

.....

.....

(3 marks)

- (c) A resistor is made by connecting two uniform cylinders X and Y of the same material and equal in length, in series.

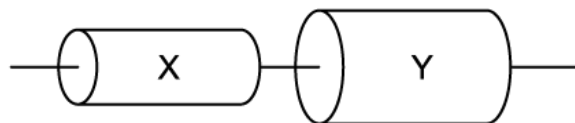

Cylinder Y has a resistance of $5\ \Omega$ and is twice the diameter of cylinder X.

Calculate the total resistance of this series combination.

.....

(1 mark)

- (d) State and explain why knowledge of quantities like resistivity is useful to scientists.

(2 marks)

- 4 (a) A variable resistor R_1 has a resistance that varies between 0 and $10\ \Omega$ is connected to two resistors R_2 and R_3 and two cells of e.m.f. 5 V and 6 V.

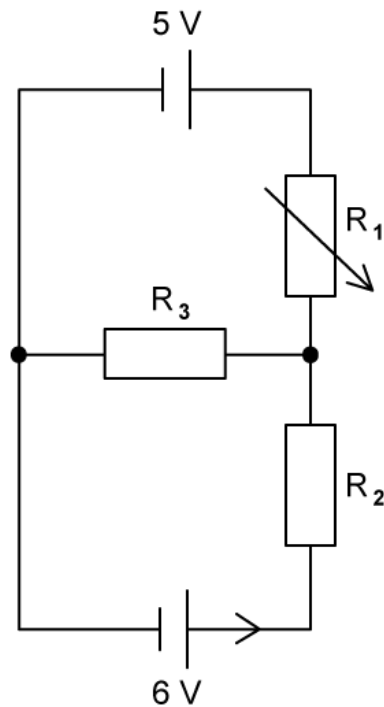

Deduce an expression for three currents I_1 , I_2 and I_3 at the junction between the resistors R_1 , R_2 and R_3 .

(2 marks)

- (b) Initially, the variable resistor R_1 is set to $0\ \Omega$.

If R_2 is $5\ \Omega$ and R_3 is $10\ \Omega$, determine the current through resistor R_2 .

(4 marks)

5 A circuit includes three fixed resistors and a thermistor with variable resistance R .

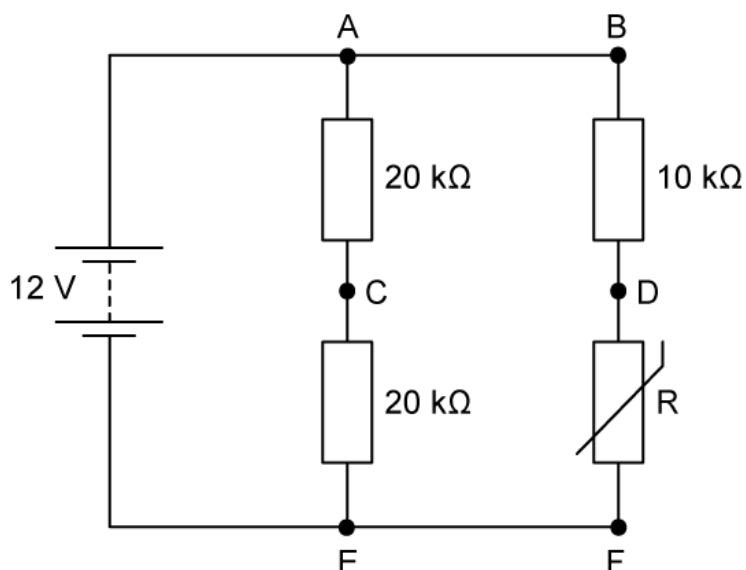

The battery has an e.m.f. of 12 V, with negligible internal resistance. At room temperature, the resistance of the thermistor is 4.0 kΩ.

Calculate the current in the battery at room temperature.

(4 marks)

6 (a) An electronic circuit contains two resistors connected as shown.

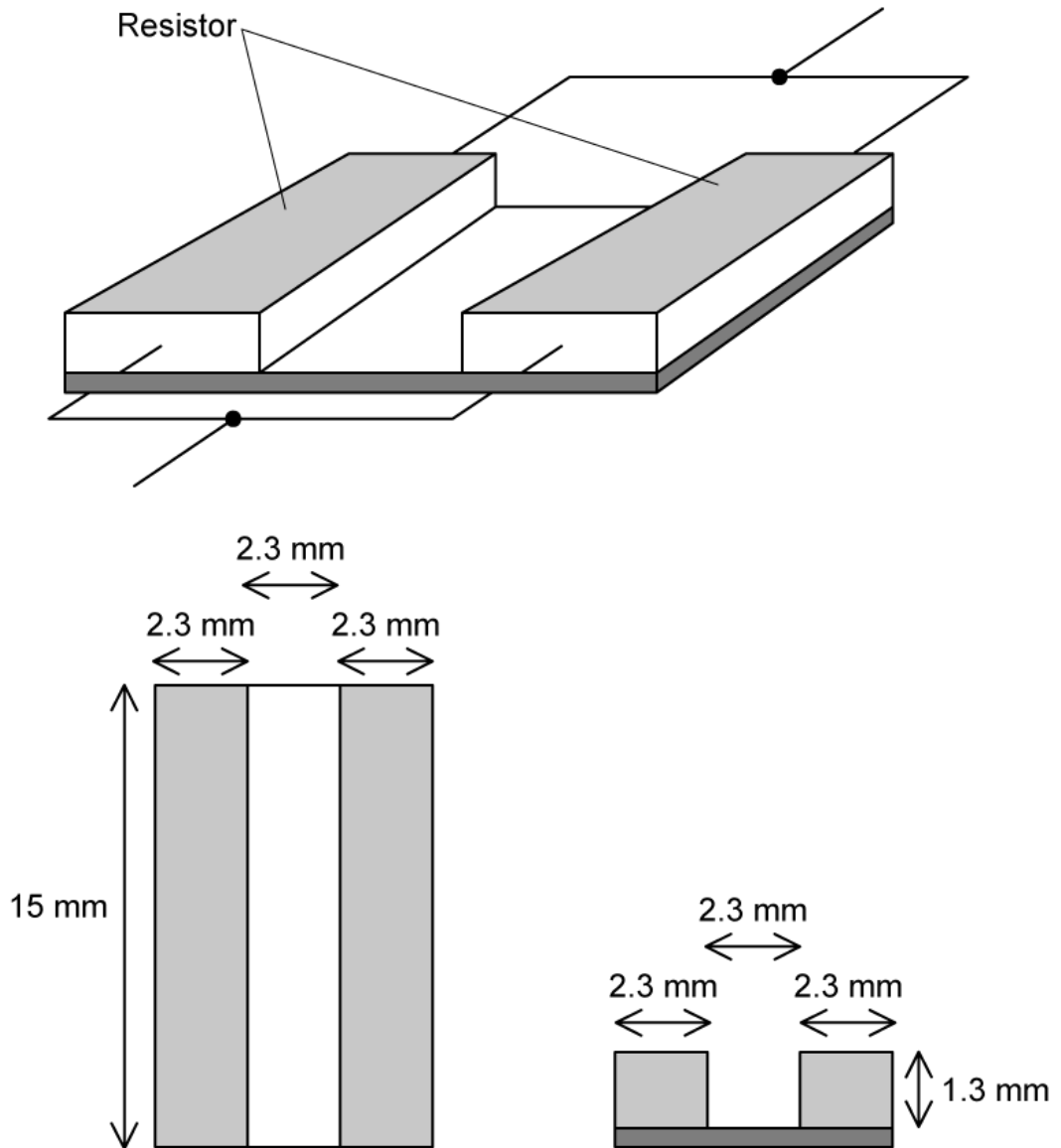

The material from which each resistor is made has a resistivity of $2.0 \times 10^5 \Omega \text{ m}$ and both resistors have dimensions of 15 mm by 2.3 mm by 1.3 mm.

Calculate the total resistance of the electronic circuit.

(2 marks)

- (b) The circuit is designed such that changes to the dimensions of each resistor by a common factor x are easily accomplished.

Show that if the dimensions of each resistor are increased by a factor of x then the resistance decreases by the same factor.

.....

.....

(2 marks)

- (c) An electrical heating element is made of nichrome wire of resistivity $1.1 \times 10^{-6} \Omega \text{ m}$. It is required to dissipate 800 W when connected to the 230 V mains supply. The radius of the wire is 0.17 mm.

Calculate the length of wire required for the heating element.

.....

.....

.....

.....

(4 marks)

- (d) Suggest **two** properties that the nichrome wire must have to make it suitable as an electrical heating element.

.....

.....

(2 marks)

- 7 (a) The diagram below shows two circuits A and B that were used by a student to test a battery of four identical cells. In circuit A, there was no load resistor and in circuit B a load resistor was connected. Assume that the meters in the circuits are ideal.

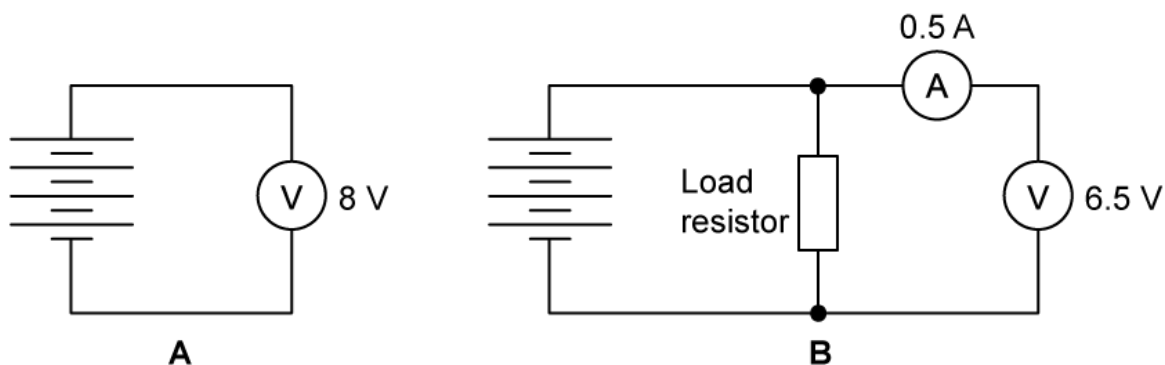

Explain why there is a difference in voltages recorded in the two circuits.

.....

.....

.....

(3 marks)

- (b) Calculate the internal resistance of a single cell.

.....

.....

.....

(3 marks)

- (c) In circuit B, the resistance of the load resistor R is altered so that a series of values on the voltmeter and the corresponding values of the current on the ammeter are obtained.

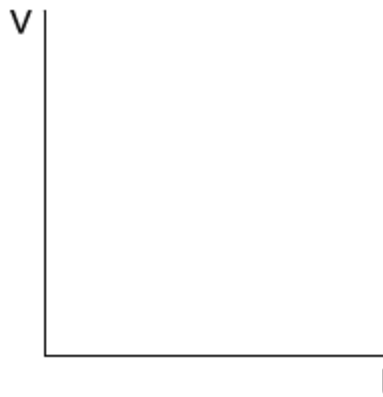

(i) On the axes above, sketch the graph you would expect to obtain as R is changed.

[2]

(ii) Outline how the values of ε and r can be obtained from the graph.

[2]

.....

.....

.....

.....

(4 marks)

(d) A cell is connected to an external resistor and the terminal voltage across the cell monitored. The graph shows the discharge time for one cell with a current of 0.5 A.

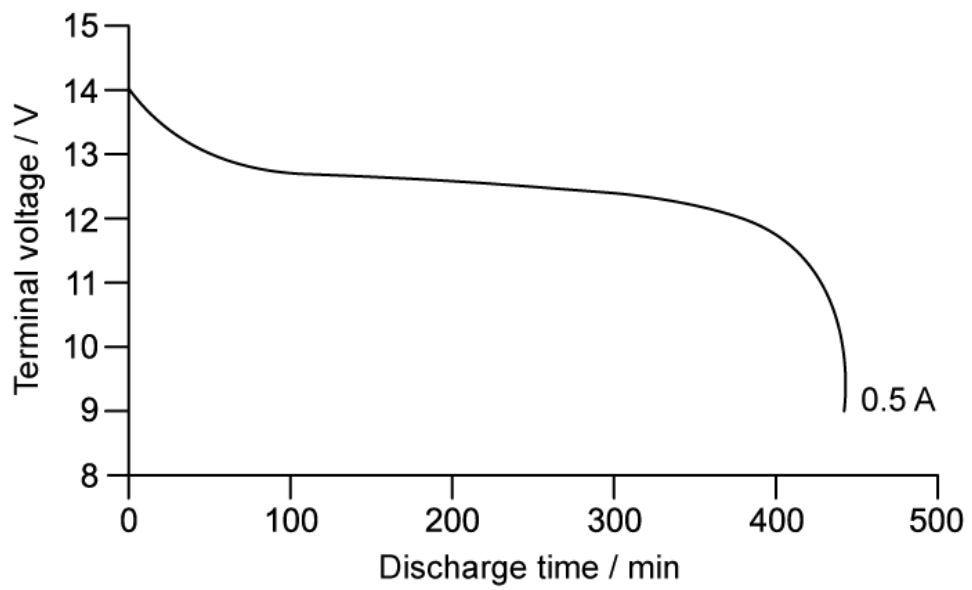

Determine the terminal voltage of the single cell. Show your working clearly.

(2 marks)

8 (a) The diagram shows a battery of e.m.f. 40.0 V and internal resistance, r .

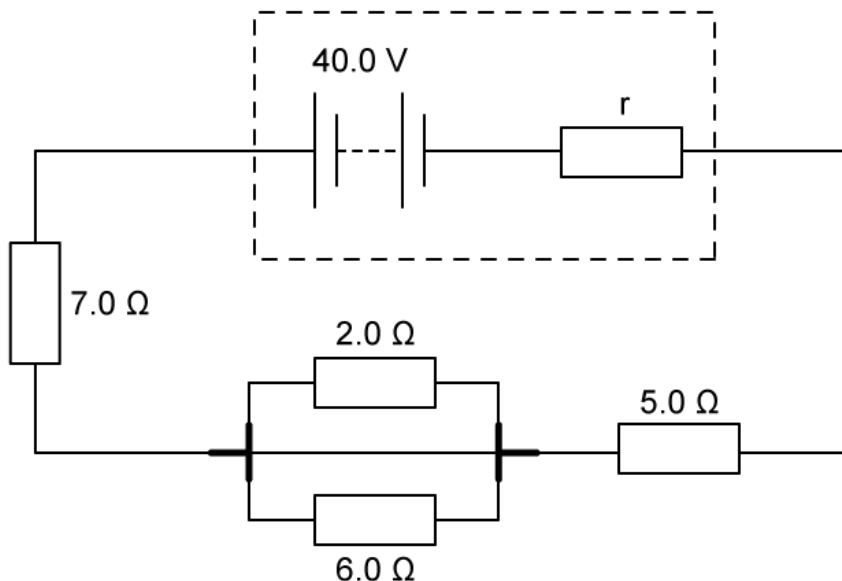

The current in the battery is 2.5 A.

Calculate the internal resistance r .

(3 marks)

(b) Calculate the energy dissipated in the battery in 3.5 minutes.

(1 mark)

(c) The circuit is amended to include a solar cell.

Explain the function of a solar cell and an advantage it has in an electric circuit over a chemical cell.

(2 marks)

- (d)** The internal resistance of the cell affects the efficiency of the transfer of energy from the cell to the circuit.

Explain what causes internal resistance and why this affects the efficiency of the cell.

.....

.....

(2 marks)

- 9 (a) The diagram shows a cell of e.m.f. ϵ , and internal resistance, r , is connected to a variable resistor R . The current through the cell and the terminal p.d. of the cell are measured as R is decreased.

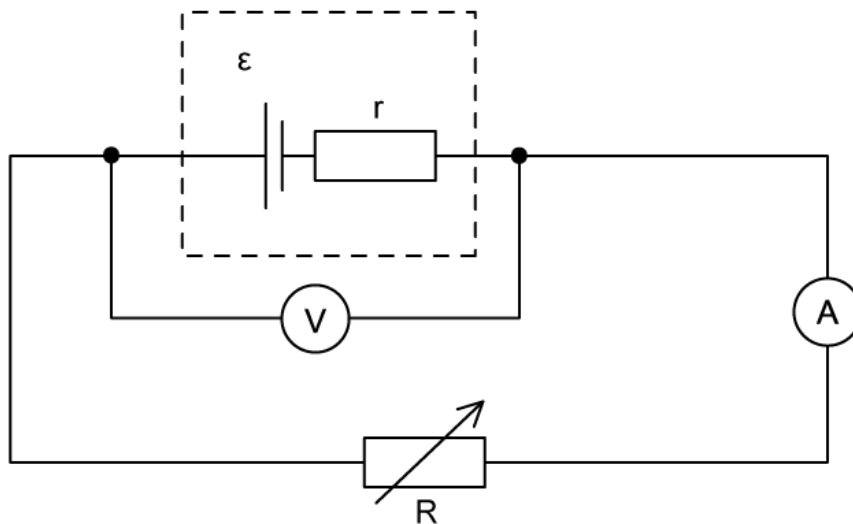

The graph below shows the results from the experiment.

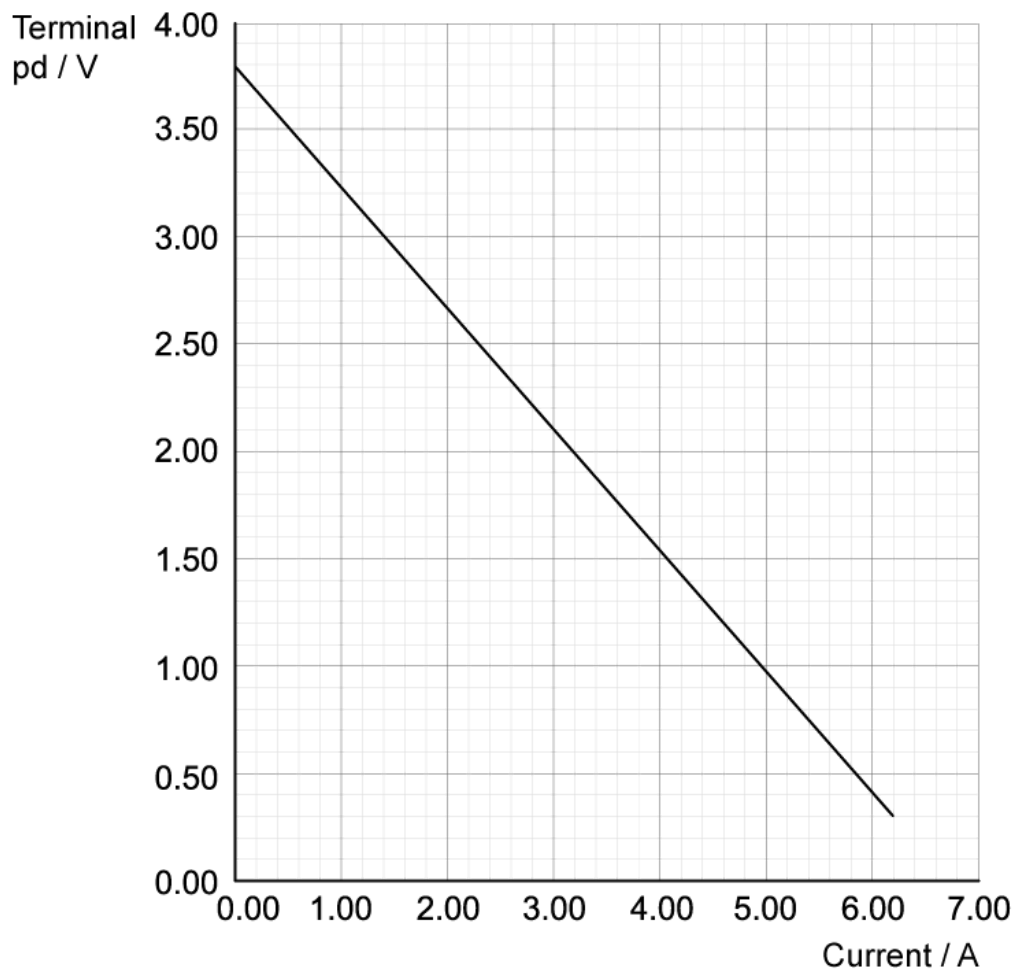

State the relationship between the terminal p.d. and current and explain why this relationship occurs.

.....

.....

.....

(3 marks)

(b) Find the e.m.f., ϵ , and the internal resistance, r , of the cell.

.....

.....

.....

(3 marks)

(c) Draw a line on the graph above to show the results obtained from a cell with the half the e.m.f. but double the internal resistance of the first cell. Label your graph **A**.

.....

.....

(2 marks)

(d) Draw a line on the same graph to show the results obtained from a cell with the same e.m.f. but negligible internal resistance. Label your graph **B**.

.....

.....

(2 marks)

10 (a) A battery is connected to an 9.0Ω resistor. The e.m.f. of the battery is 12 V .

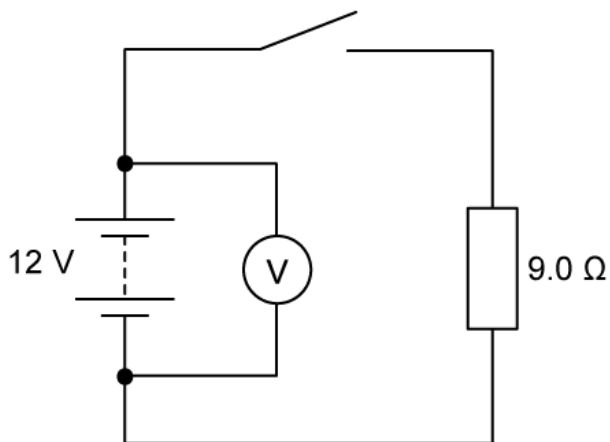

When the switch is open the voltmeter reads 12 V and when it is closed it reads 11.3 V .

Explain why the readings are different.

(3 marks)

(b) Calculate the internal resistance of the battery.

(3 marks)

(c) The circuit diagram shows that the 9.0Ω resistor is now connected in parallel with an unknown resistor, R . The battery now supplies a current of 3.0 A and has the same internal resistance r as the previous circuit.

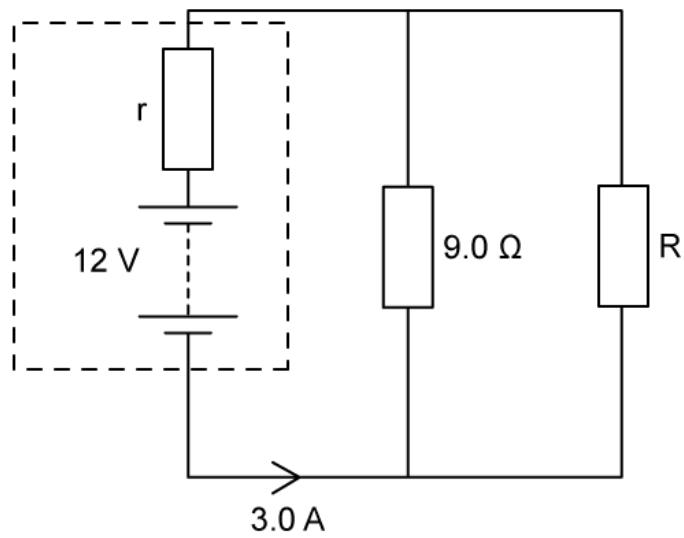

Calculate the p.d. across the 9.0Ω resistor.

.....

.....

(2 marks)

(d) Calculate the resistance of R .

.....

.....

.....

(3 marks)

- 11 (a) A very high resistance voltmeter reads 11.5 V when it is connected across the terminals of a power supply.

Explain why the reading on the voltmeter is equal to the E.m.f. of the power supply.

(3 marks)

A battery of e.m.f. 11.5 V and internal resistance r is connected in a circuit with three identical 13Ω resistors. A current of 0.40 A flows through the battery.

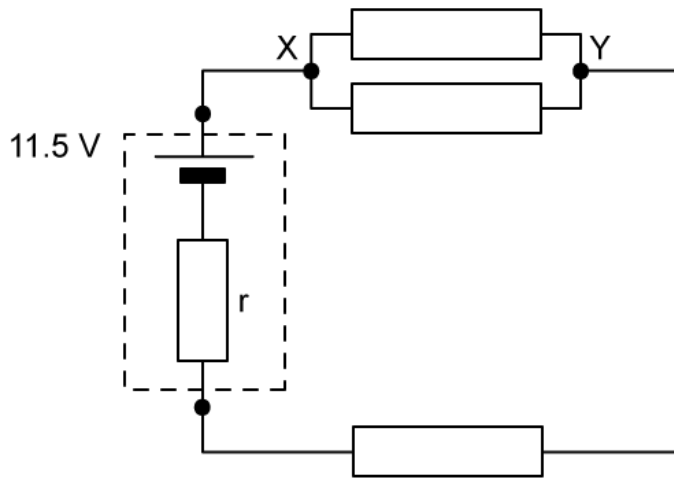

- (b) Calculate the potential difference between points X and Y in the circuit.

(2 marks)

- (c) Calculate the internal resistance of the battery.

(3 marks)

Hard Questions

- 1 (a) A combination of identical resistors each with resistance R has a total resistance of 250Ω .

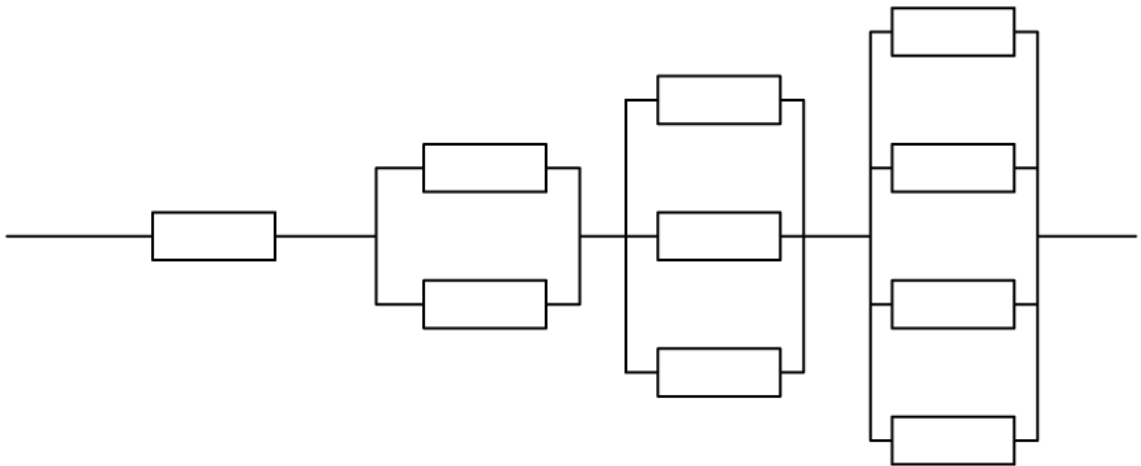

Show, without the use of a calculator, how to find the value of resistance of each resistor and hence determine the value of R .

(2 marks)

(b) A student is provided with four fixed resistors of the following sizes:

$$1 \times 5.0 \, \Omega$$

$$1 \times 10.0 \, \Omega$$

$$2 \times 20.0 \, \Omega$$

Calculate the maximum power which can be drawn from a circuit which uses all four resistors connected to a variable power supply with terminal voltage ranging from 2-12 V. Include a sketch of the circuit you have outlined in your answer.

(4 marks)

(c) A physics class planned an investigation into electromotive force (emf) and internal resistance. When the students arrived the equipment had not been set out as they expected. They were provided with the circuit diagram shown, and a set of ten fixed resistors, ranging from 10-200 Ω in regular increments which could be used in place of the resistor, R .

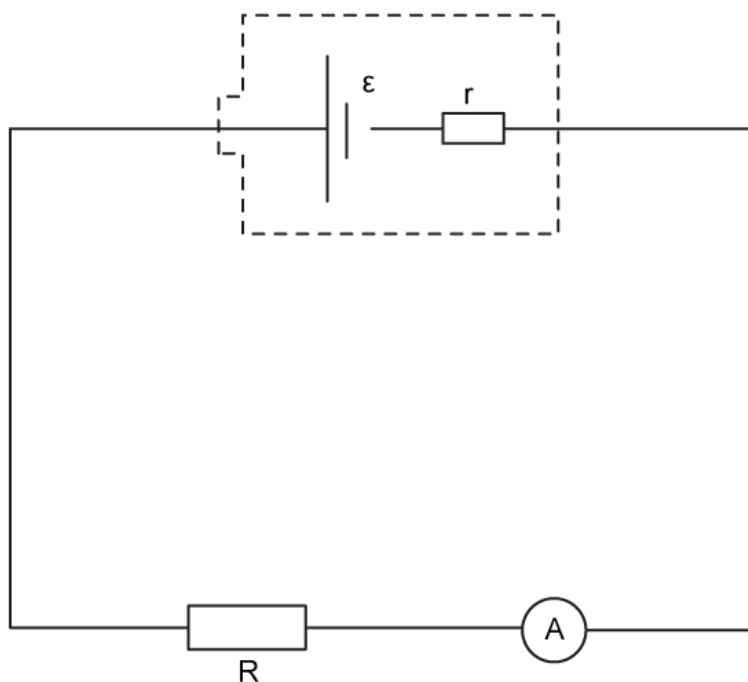

Comment on how the students can use their results to find both the emf and the internal resistance of the cell and hence suggest the outcome of this investigation.

Assume that the ammeter is suitable to measure all the currents which this circuit may produce. No additional equipment may be used.

.....

.....

.....

(3 marks)

- (d) The circuit diagram shows a battery which has negligible internal resistance connected to three resistors which have different values of resistance.

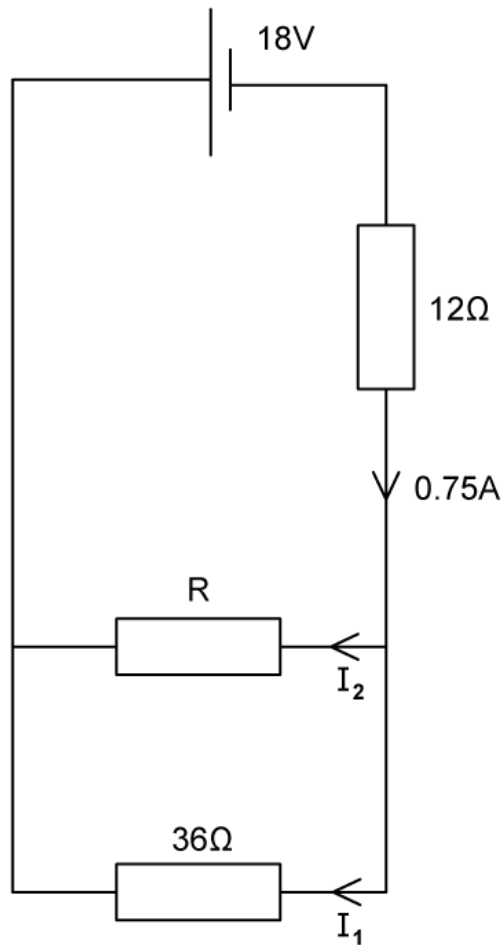

(i) Calculate current I_1 .

[1]

(ii) Calculate resistance, R .

[1]

(2 marks)

2 (a) A current of 2.0 mA flows in an ammeter for 90 minutes.

Calculate the approximate number of electrons which pass through the ammeter in this time.

(1 mark)

(b) Human skin tissue has much higher resistivity than muscle tissue. Typical values for the resistivity of particular tissue types vary. For this question use the data in the table below.

Tissue	Resistivity / Ω m
Muscle	8.3
Dry skin	3.0×10^4

A person grasps a wire which has a diameter of 0.5 cm at a potential of 12 V. The wire is not insulated and the person is well earthed. The skin of the hand is 1.0 mm thick and is in contact with the whole wire for a distance of 10 cm.

(i) Calculate the current in mA which passes through the person as a result of this accident.

[2]

(ii) Comment on the change as the current passes through the skin and into the muscle tissue.

[2]

(1 mark)

- (c) Following the accident in part (b) the teacher sets a research homework, where students are asked to discuss electrical safety.

By comparing the factors given in the question

- (i) Suggest how the magnitude of the current passing into the body could have been affected. [2]
- (ii) Outline safety precautions which the student should have taken before handling the wire. [3]

(1 mark)

- (d) High voltage electrical accidents can cause deep burns throughout the body, which often require major surgery and can lead to permanent disability or death.

Outline the reasons for this level of injury, stating two assumptions that you have made in your explanation.

(4 marks)

3 (a) The variation with temperature of the resistance, R_T of a thermistor with temperature is shown.

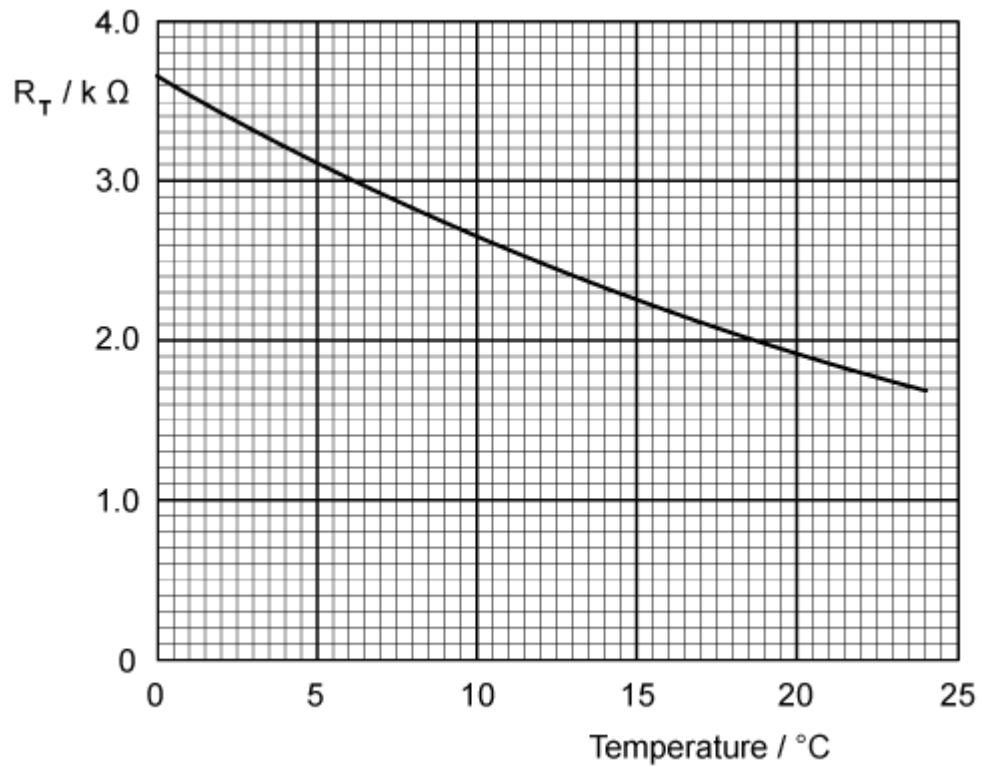

The thermistor is connected into a circuit using a power source with negligible internal resistance. The temperature is $22.5^{\circ}C$.

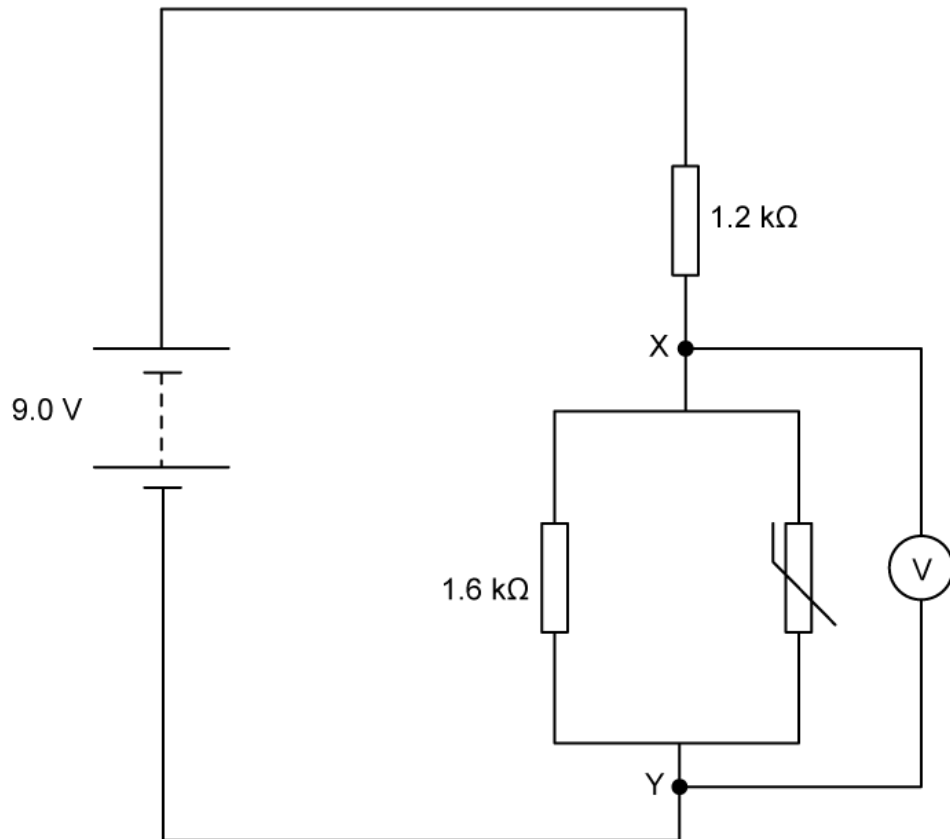

Show, without the use of a calculator, how to determine the reading on the voltmeter, giving the answer to two significant figures.

.....
(1 mark)

(b) The temperature is changed so that the voltmeter reads 4.0 V.

Determine the new temperature.

.....

(2 marks)

- 4 (a) Show that $I^2R = \frac{V^2}{R}$ and hence express the unit represented by these equations in S.I. units.

(2 marks)

- (b) A family on a tight budget needs to buy a new electric heater. The retailer's website, written (it claims) by electrical engineers, suggests that the best value-for-money heater has very high resistance because $P = I^2R$.

The family, who all study physics, think that a low resistance heater would be better,

because $P = \frac{V^2}{R}$.

Explain who is correct.

(2 marks)

- (c) Two thin strips of silver and of iron have the same dimensions. The strips are connected to a circuit, first in series and then in parallel. A potential difference is applied in the positions shown, and the voltage increased incrementally until one of the two wires begins to glow.

(i)

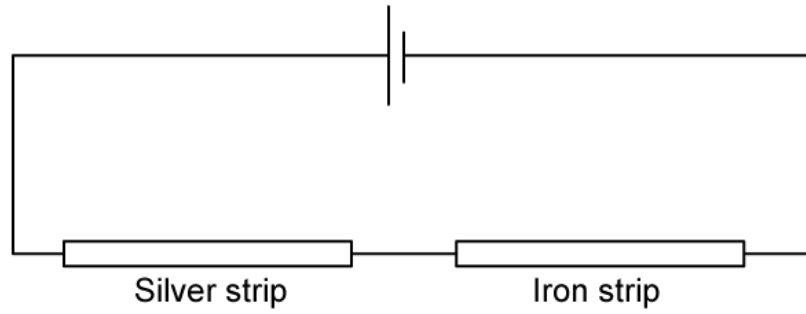

(ii)

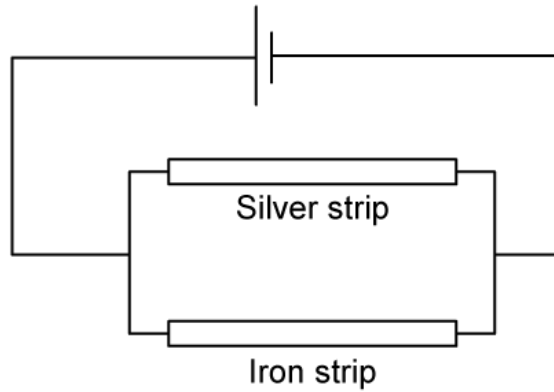

Explain which metal strip will glow first

(i) For the series arrangement.

[2]

(ii) For the parallel arrangement.

[2]

.....

.....

.....

.....

(4 marks)

- 5 (a) In a thought experiment a teacher asks students to imagine an electron passing through a cell with a terminal voltage of 9 V.

The electron passes along a wire until it reaches the positive terminal of the cell. In the thought experiment, students are asked to assume that there is no obstruction to the movement of the electron within the wire.

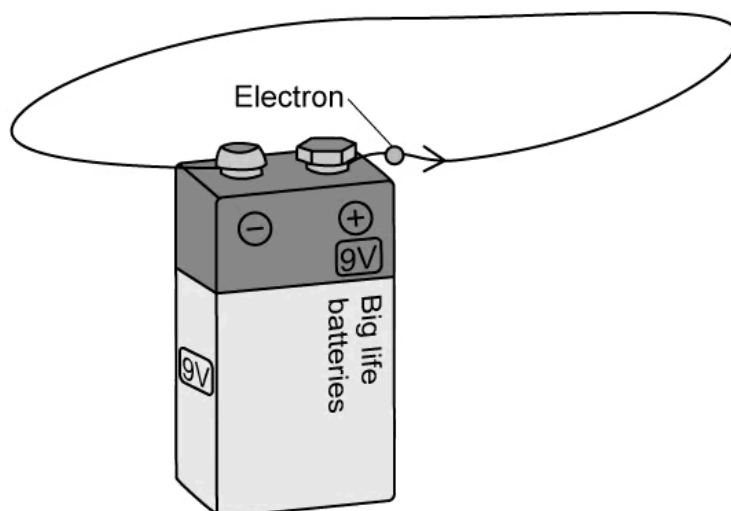

Using energy considerations, calculate the final speed of the electron.

(2 marks)

- (b) The teacher points out that the thought experiment is fundamentally flawed, since it breaks a certain law of physics.

Explain the teacher's comment, and hence use a simple observation from daily experience to prove that the teacher is correct.

(2 marks)

- 6 (a) A uniform wire of length 80 cm and radius 0.50 mm is connected in series with a cell of e.m.f. 3.0 V and an internal resistance of 0.70 Ω .

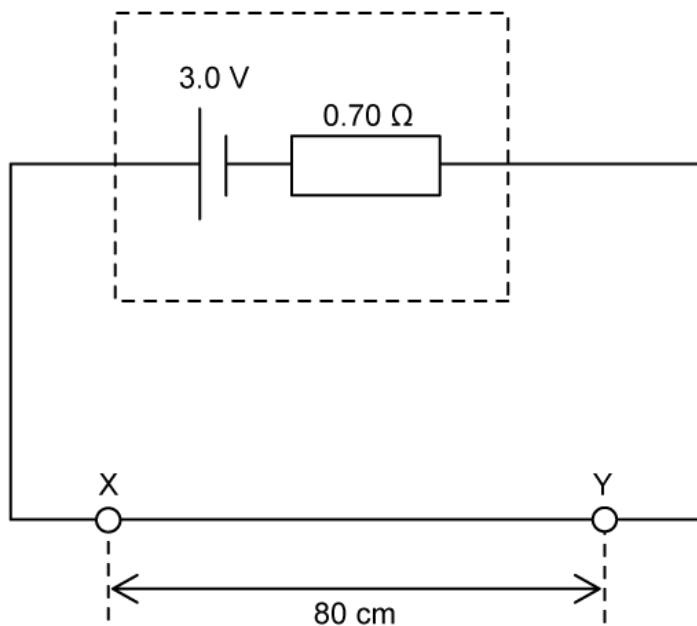

The resistivity of the metal used to make the wire is $1.10 \times 10^{-6} \Omega \text{ m}$.

Determine the current that flows in the cell.

(2 marks)

- (b) A voltmeter is connected at X, with a movable probe C, such that the voltmeter is able to read the potential difference across the wire at different points between X and Y.

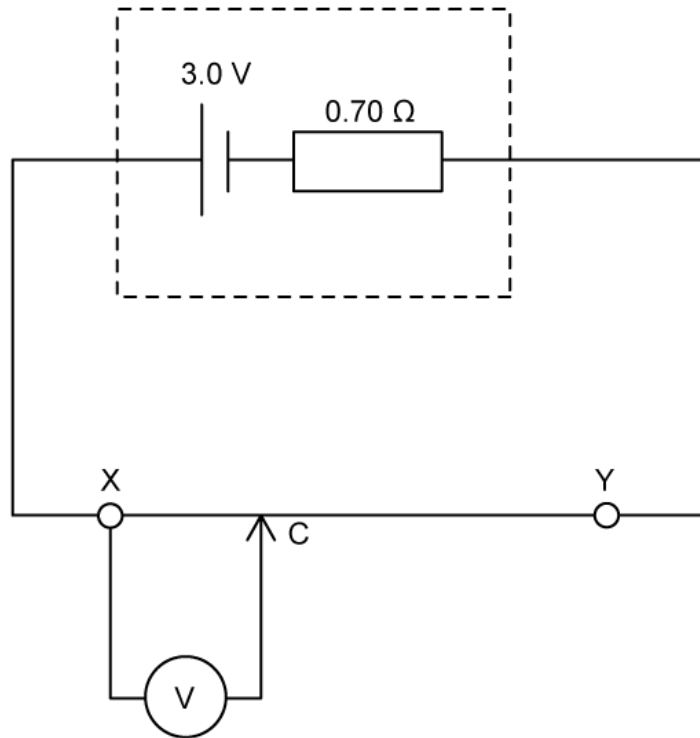

Sketch a graph on the set of axes below which shows how the potential difference V varies between X and Y as the sliding contact C moves from X to Y.

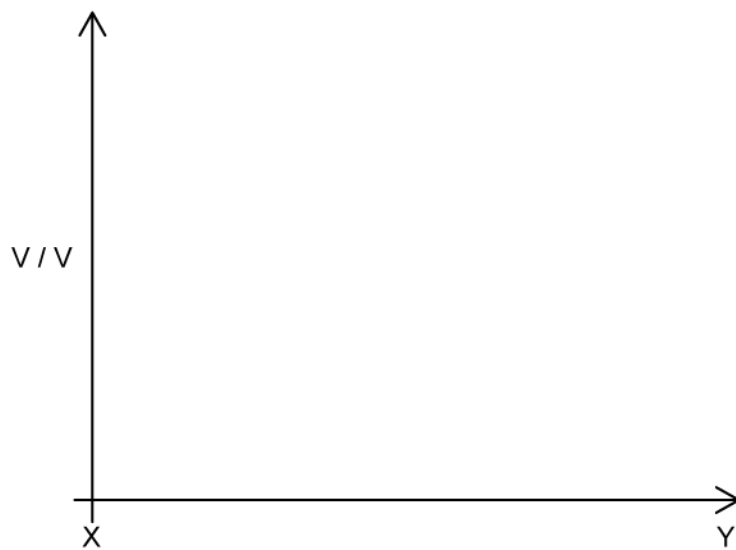

(4 marks)

- (c) The voltmeter in (b) is replaced with a cell of e.m.f. 1.5 V with internal resistance 0.50Ω , and an ammeter:

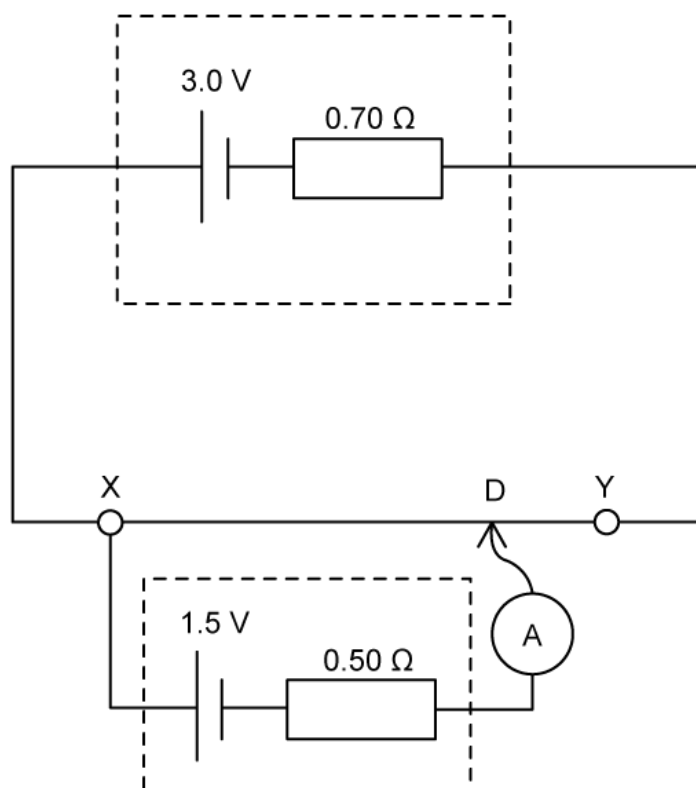

The moveable contact can again be connected to any point along the wire XY. At point D, there is zero current in the ammeter.

Calculate the length of XD.

(4 marks)

- 7 (a) The Maximum Power Transfer theorem says the maximum amount of electrical power is dissipated in a load resistance R_L when it is exactly equal to the internal resistance of the power source r .

The circuit below is used to investigate maximum power transfer.

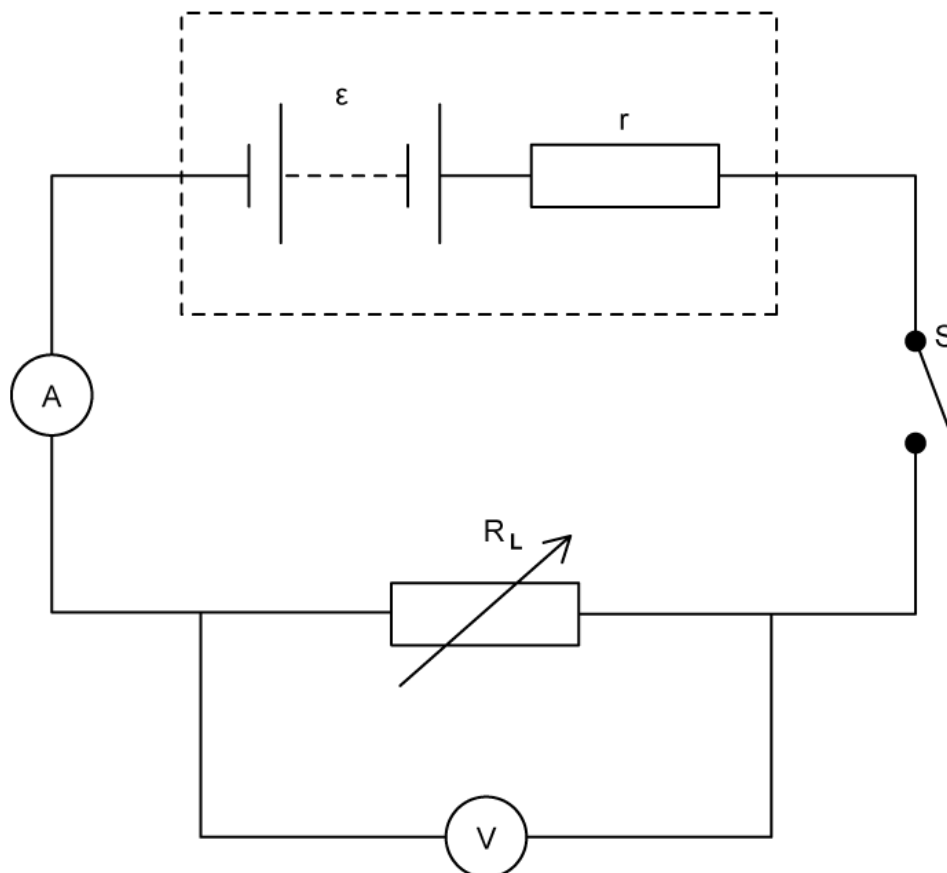

A variable resistor, which acts as the load resistance R_L , is connected to a power source of e.m.f. ϵ and internal resistance r , along with a switch S and an ammeter and voltmeter.

The graph below shows the results obtained for the power P dissipated in R_L as the potential difference V across R_L is varied:

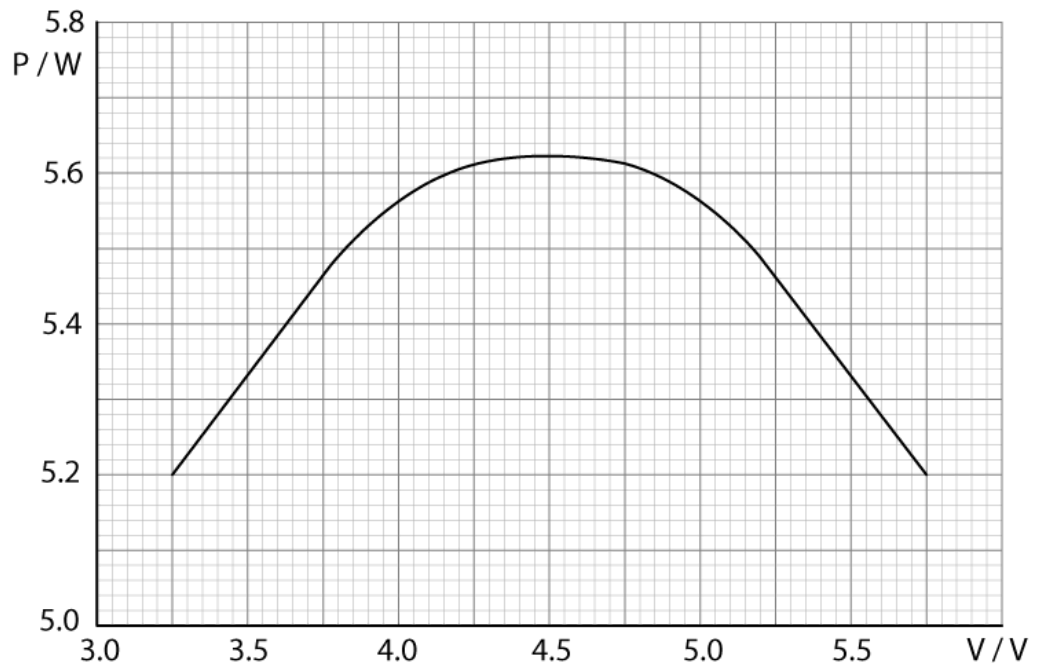

Assuming the Maximum Power Theorem is valid, use the graph to determine the internal resistance of the power source.

.....

.....

.....

(3 marks)

(b) Show that the e.m.f. of the power supply is 9 V.

.....

.....

.....

(3 marks)

(c) Identify what happens to each of the following quantities as the value of the load resistance R_L becomes infinitely large:

- (i) Current. [1]
- (ii) Potential difference across R_L . [1]
- (iii) Power dissipated in R_L . [1]

.....

.....

.....

(3 marks)

(d) It can be shown that the power P dissipated in the load resistance R_L is zero when the load resistance is zero.

Sketch a graph on the axes provided to show how the power dissipated P varies with load resistance R_L .

Label the position of the internal resistance, r .



.....

(3 marks)

- 8 (a)** The diagram shows a circuit which can be used to investigate the internal resistance r of a power supply. In this case, a battery consisting of six dry cells in series, each of e.m.f. $\epsilon = 0.5 \text{ V}$, is connected to an oscilloscope:

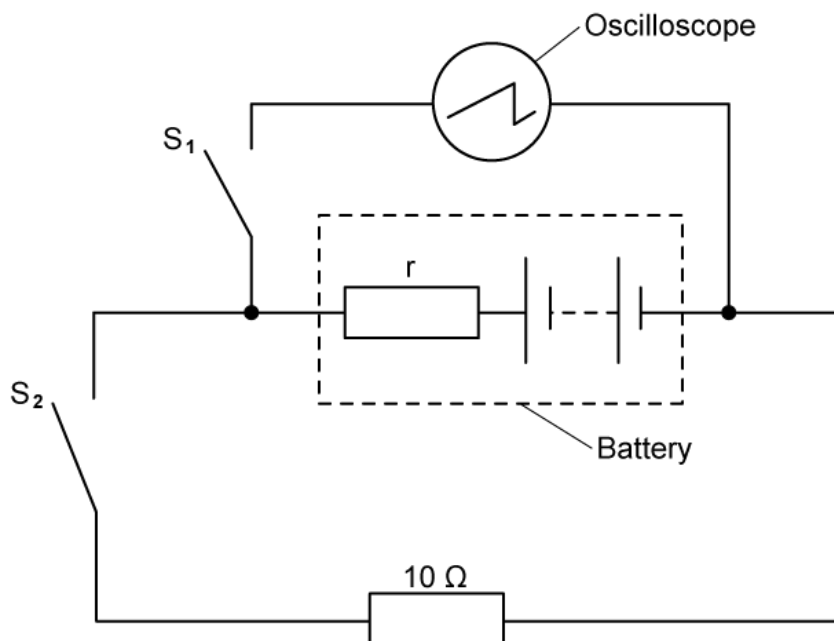

The chart below represents the trace shown on the oscilloscope screen when both of the switches S_1 and S_2 are open:

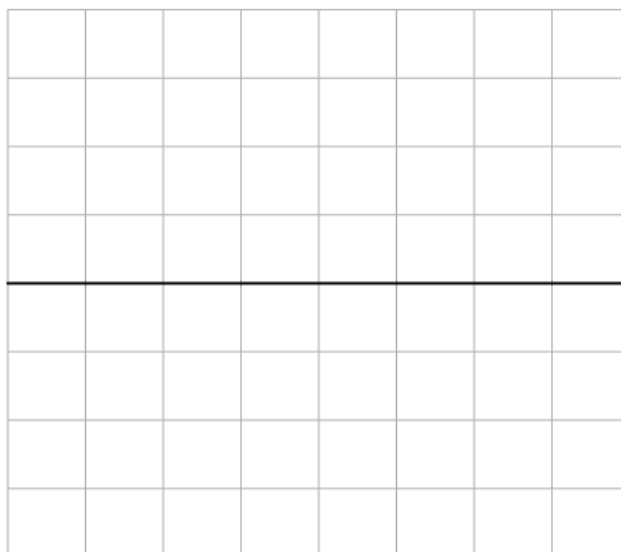

The y-gain of the oscilloscope is set at 1.5 V div^{-1} .

Discuss what happens to the trace shown on the oscilloscope screen when switch S_1 is closed.

(4 marks)

(b) Draw the trace on the oscilloscope screen when both switches S_1 and S_2 are closed. Explain your answer.

(3 marks)

(c) Calculate the internal resistance of the battery if the vertical distance between the traces in part (a) and part (b) is measured to be half a division.

(3 marks)

(d) Determine the current in the cell that would move the trace shown on the oscilloscope screen back to its original position as shown in part a. Assume both switches, S_1 and S_2 , remain closed.

(2 marks)

9 (a) Understanding the properties of e.m.f. and internal resistance can help the design decisions of architects and electrical engineers.

In an experiment to investigate power dissipation across two lamps, L_1 and L_2 , an engineer connects them in a series circuit to a cell of e.m.f. 45 V and internal resistance 7Ω .

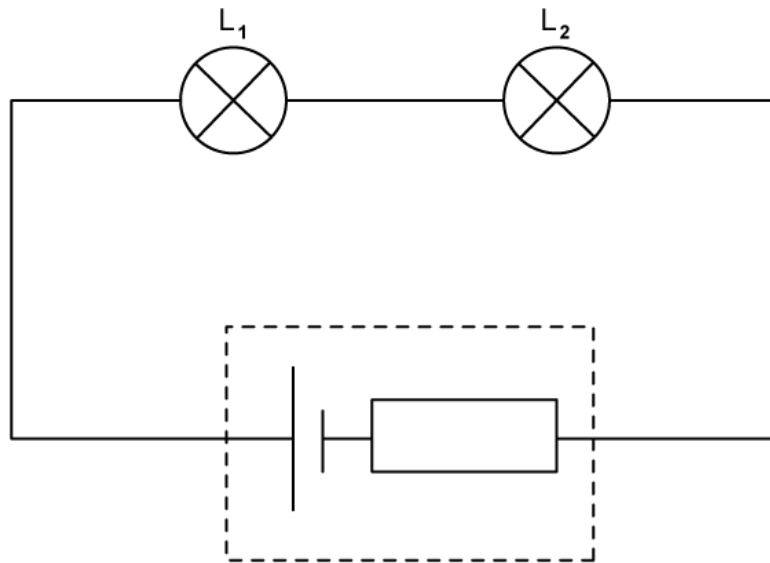

The lamp L_1 has a resistance of 10Ω and L_2 has a resistance of 25Ω .

Calculate the percentage difference between the power generated by the cell and the power dissipated in the two lamps L_1 and L_2 . Suggest a reason for this percentage difference.

.....

.....

.....

.....

.....

(5 marks)

- (b) The engineer wishes to maximise the power dissipated across each lamp and explores various alternatives to the circuit shown in part a.

Suggest and explain, using appropriate calculations, how the engineer should arrange the lamps L_1 and L_2 such that the power dissipated in each lamp is maximised.

(6 marks)

- (c) The engineer comes up with a theoretical problem, which involves arranging a large number of identical lamps in parallel with each other, as illustrated below:

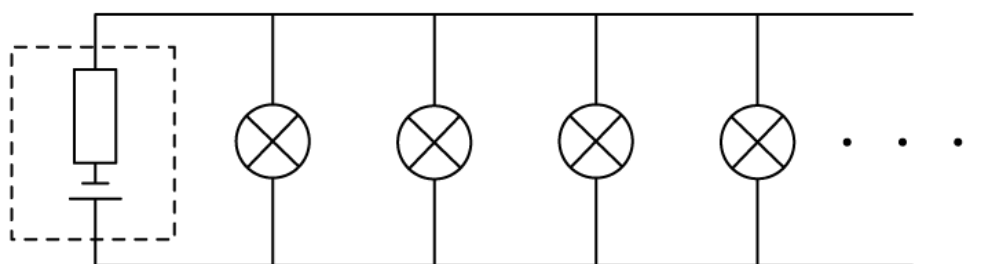

The lamps are connected to a cell of e.m.f. ϵ and internal resistance r .

Discuss the effect on the terminal p.d. supplied by the cell, and hence on the lamps, as more lamps are added in parallel.

(3 marks)