

 **SL IB Physics**  
Your notes

## Structure of the Atom

### Contents

- \* Rutherford's Gold Foil Experiment
- \* Nuclear Notation
- \* Emission & Absorption Spectrum
- \* Photon Energy



Your notes

## Rutherford's Gold Foil Experiment

### Rutherford's Gold Foil Experiment

- Evidence for the structure of the atom was discovered by Ernest Rutherford at the beginning of the 20th century from the study of **alpha particle scattering**
- The experiment consisted of beams of high-energy alpha particles fired at thin gold foil and a detector on the other side to determine
  - The different **angles of deflection** of the alpha particles
  - The **number of alpha particles** that were deflected at each angle

### Apparatus for the Rutherford Scattering Experiment

- The setup for the scattering experiment consisted of:
  - A source of alpha particles in a lead container
  - A thin sheet of gold foil
  - A movable detector
  - An evacuated chamber

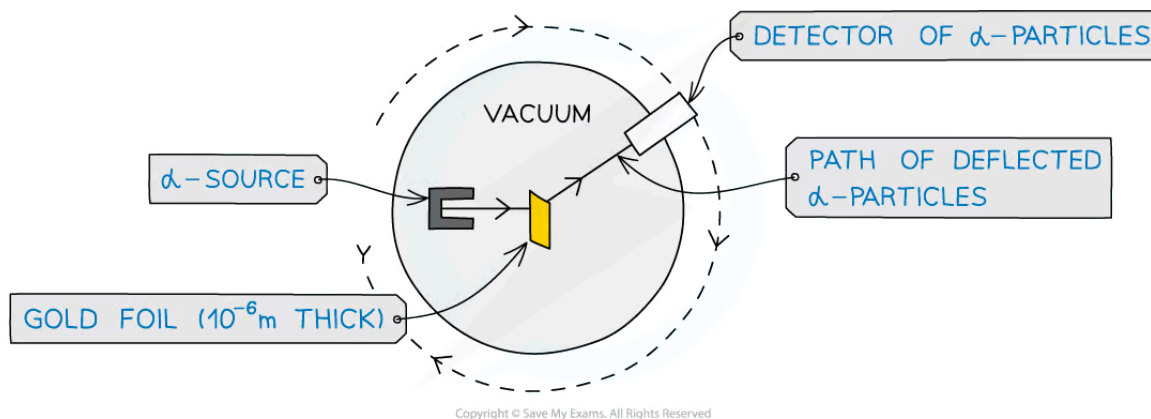

*Experimental set up for  $\alpha$ -particle scattering*

#### Purpose of the lead container

- Alpha particles are emitted in all directions, so the source was placed in a **lead container**
- This was to produce a collimated beam of alpha particles
- This is because alpha particles are absorbed by lead, so a long narrow hole at the front allowed a concentrated beam of alpha particles to escape and be directed as needed

#### Purpose of the thin sheet of gold foil

- The target material needed to be **extremely thin**, about 10<sup>-6</sup> m thick
- This is because a thicker foil would stop the alpha particles completely
- Gold was chosen due to its malleability, meaning it was easy to hammer into thin sheets

#### Purpose of the evacuated chamber

- Alpha particles are highly ionising, meaning they only travel about 5 cm before interacting with molecules of air
- So, the apparatus was placed in an **evacuated chamber**
- This was to ensure that the alpha particles did not collide with any particles on their way to the foil target

## Findings from the Rutherford Scattering Experiment

- An alpha ( $\alpha$ ) particle is the nucleus of a helium atom, so it has a **positive** charge

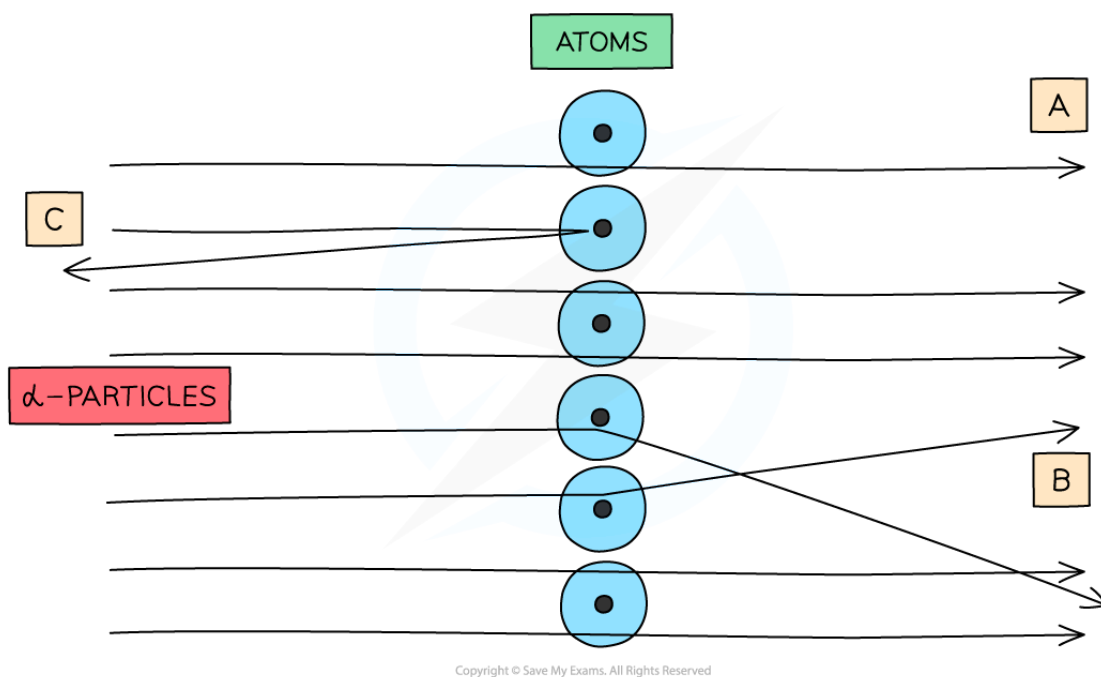

**When  $\alpha$ -particles are fired at thin gold foil, most of them go straight through but a small number bounce straight back**

- The observations from Rutherford's experiment were:
  - The majority of  $\alpha$ -particles passed straight through the foil undeflected**
    - This suggests the atom is mostly empty space
  - Some  $\alpha$ -particles deflected through small angles of  $<10^\circ$** 
    - This suggests there is a positive nucleus at the centre (since two positive charges would repel)
  - Only a small number of  $\alpha$ -particles deflected straight back at angles of  $>90^\circ$** 
    - This suggests the nucleus is extremely small and is where most of the mass and charge of the atom are concentrated
    - This led to the conclusion that atoms consist of small, dense positively charged nuclei surrounded by negatively charged electrons

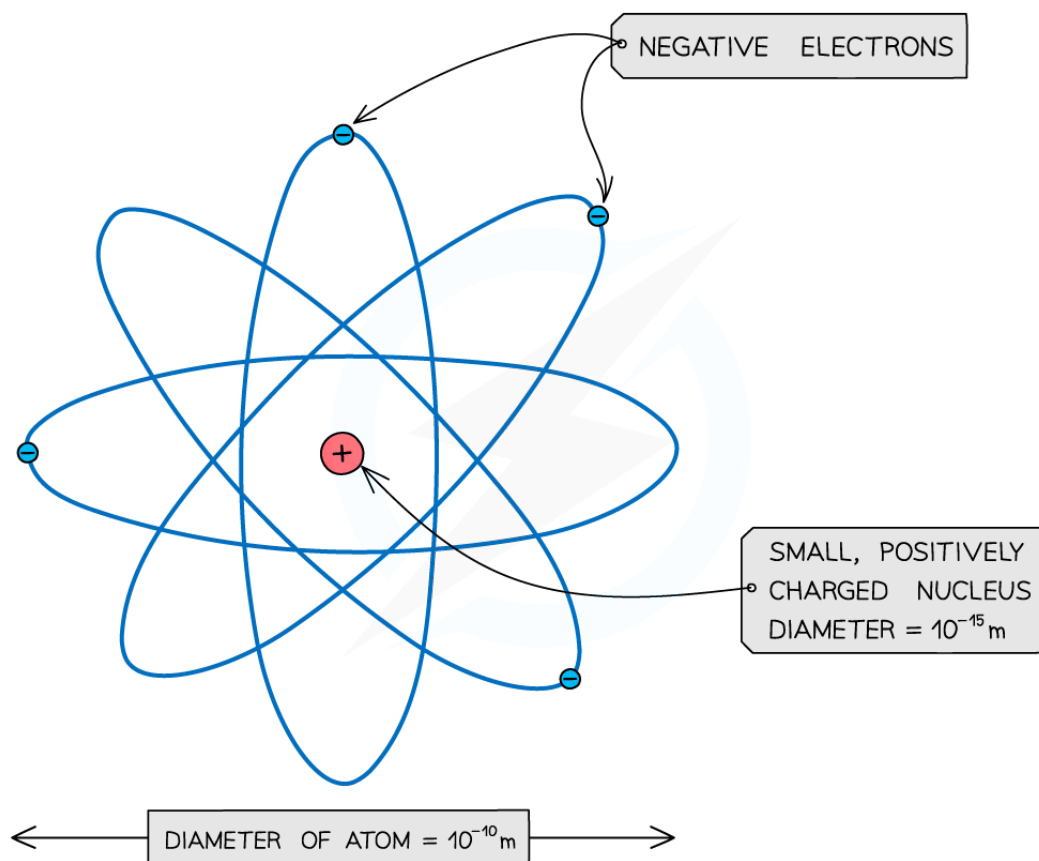

Copyright © Save My Exams. All Rights Reserved

***An atom: a small positive nucleus, surrounded by negative electrons***

- (Note: The atom is around 100,000 times larger than the nucleus!)



Your notes

### Worked example

In an  $\alpha$ -particle scattering experiment, a student set up the apparatus below to determine the number of  $\alpha$ -particles,  $n$ , incident per unit time on a detector held at various angles  $\theta$ .

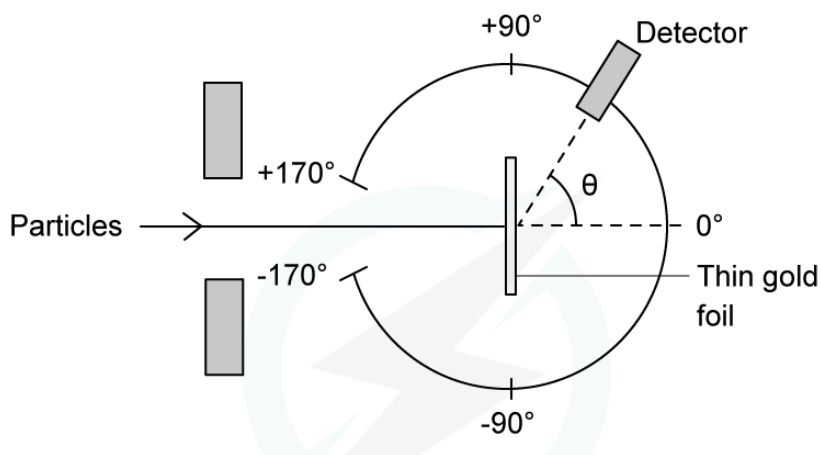

Which of the following graphs best represents the variation of  $n$  with  $\theta$  from 0 to 90°?

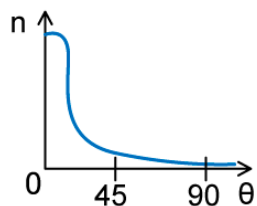
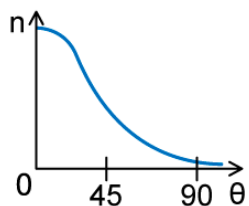
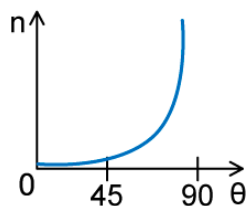
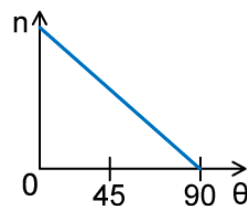
**A.**

**B.**

**C.**

**D.**

**Answer: A**

- The Rutherford scattering experiment directed parallel beams of  $\alpha$ -particles at gold foil
- The observations were:
  - Most of the  $\alpha$ -particles went straight through the foil
  - The largest value of  $n$  will therefore be at small angles
  - Some of the  $\alpha$ -particles were deflected through small angles
  - $n$  drops quickly with increasing angle of deflection  $\theta$
- These observations fit with graph A



Your notes

## Nuclear Notation

### Nuclear Notation

- All matter is made from **atoms**
- Atoms are made up of three subatomic particles:
  - Protons
  - Neutrons
  - Electrons

#### Structure of the Atom

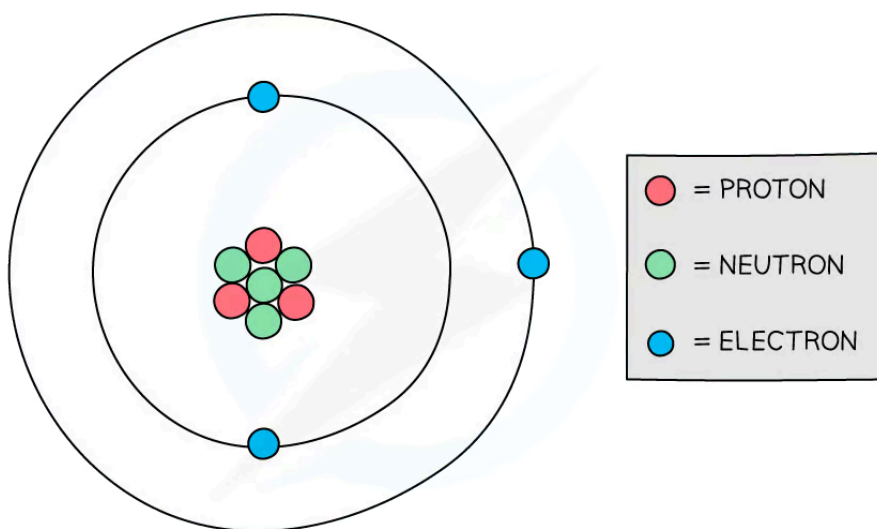

Copyright © Save My Exams. All Rights Reserved

**Protons and neutrons are found in the nucleus of an atom while electrons orbit the nucleus**

- Each of these subatomic particles has a **mass** and a **charge**
  - Charge can be expressed in coulombs (C), or units of elementary charge  $e$
  - Mass can be expressed in kilograms (kg), or in atomic mass units  $u$

**Table of properties of subatomic particles**

particle	charge / C	charge / $e$	mass / kg	mass / $u$
proton	$+1.60 \times 10^{-19}$	+1	$1.673 \times 10^{-27}$	1.007276

neutron	0	0	$1.675 \times 10^{-27}$	1.008665
electron	$-1.60 \times 10^{-19}$	-1	$9.109 \times 10^{-31}$	0.000549

- A nucleus can be described using  ${}^A_ZX$  notation

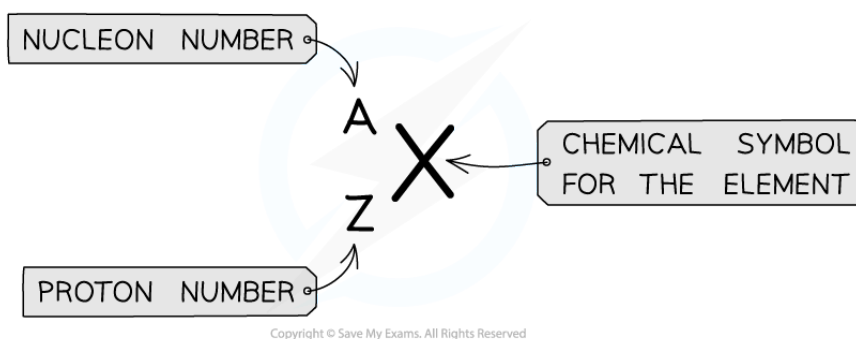

${}^A_ZX$  notation is used to describe the constituents of a nucleus

- The top number A represents the **nucleon** number or the **mass** number
  - Nucleon number (A)** = total number of **protons and neutrons** in the nucleus
- The lower number Z represents the **proton** or **atomic** number
  - Proton number (Z)** = total number of **protons** in the nucleus

### Examiner Tip

In Chemistry, you may see nucleon number referred to as mass number and proton number as atomic number. Both of these are valid, just make sure you don't mistake mass number for atomic number, or vice versa.

Make sure you know that the periodic table is ordered by **atomic number**



Your notes

## Emission & Absorption Spectrum

### Spectra & Atomic Energy Levels

- Atomic spectra are observed when atoms **emit** or **absorb** light of certain wavelengths
  - These are known as **emission spectra** and **absorption spectra**
- Atomic spectra provide **evidence** that electrons in atoms can only transition between discrete atomic energy levels

### Emission Spectra

- Emission spectra can be produced by heating a low-pressure gas
  - Heating provides energy to **excite** electrons to higher energy levels
  - When an electron transitions back to a **lower** energy level, it **emits** a photon
- Each transition corresponds to a **specific wavelength** of light which correlates to an observable spectral line
- The resulting **emission spectrum** contains a set of discrete wavelengths, represented by coloured lines on a black background

Emission spectrum of hydrogen gas

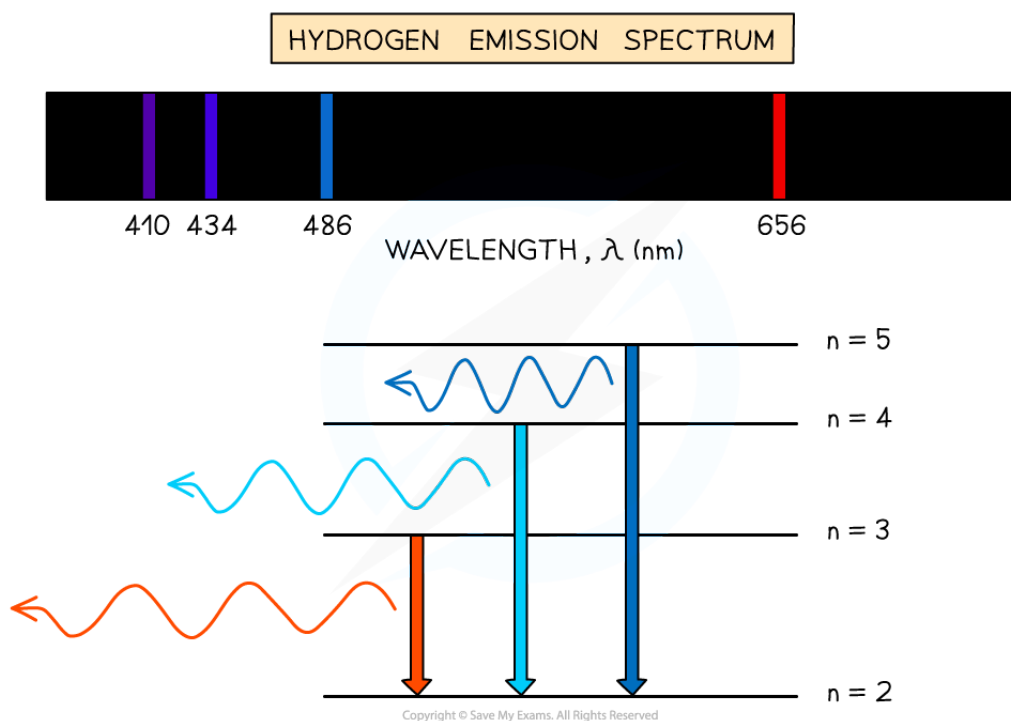

*A typical hydrogen emission spectrum contains several spectral lines in the visible region of the electromagnetic spectrum*





Your notes

## Absorption Spectra

- Absorption spectra can be produced by passing white light through a **cool, low-pressure gas**
  - Only photons with the exact energy required to excite electrons will be absorbed
- Each absorbed photon corresponds to a **specific wavelength** of light which correlates to an observable dark line in a continuous spectrum of wavelengths
- The resulting **absorption spectrum** contains a set of discrete wavelengths, represented by dark lines on a coloured background
  - These lines correspond to the same lines observed on an emission spectrum for the **same** element

### Absorption spectrum of hydrogen gas

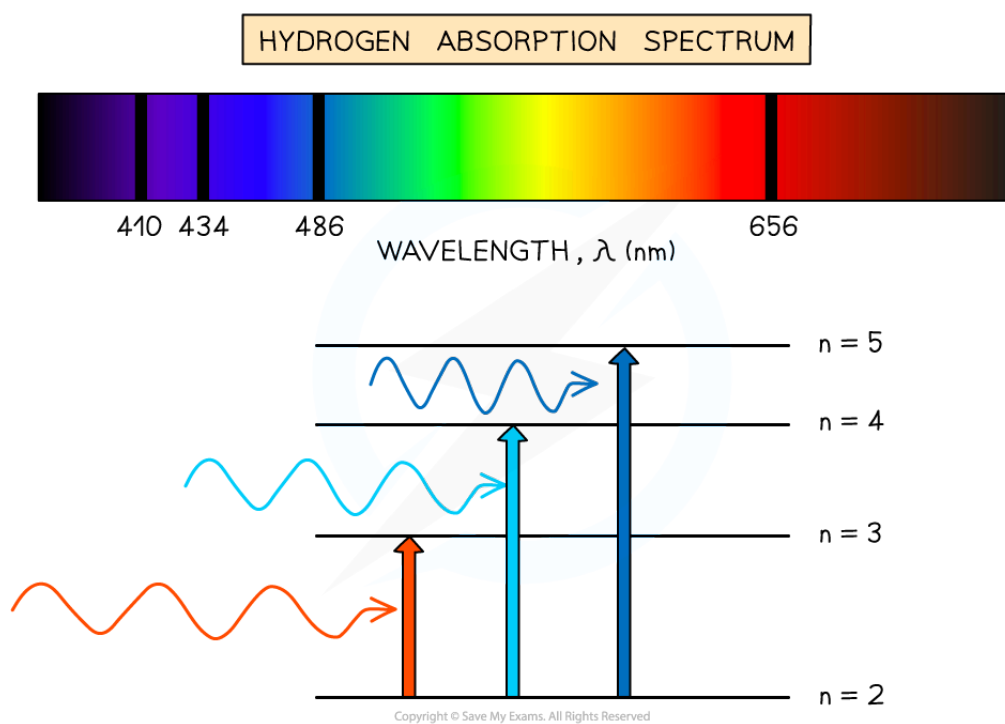

*A typical hydrogen absorption spectrum is the inverse of its emission spectrum*

## Spectra & Chemical Composition

- The **chemical composition** of a substance can be investigated using emission and absorption spectra
- Each element produces a unique pattern of spectral lines
- No two elements produce the same set of spectral lines, therefore, elements can be identified by their atomic spectrum

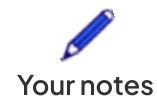

### Emission spectra of different elements

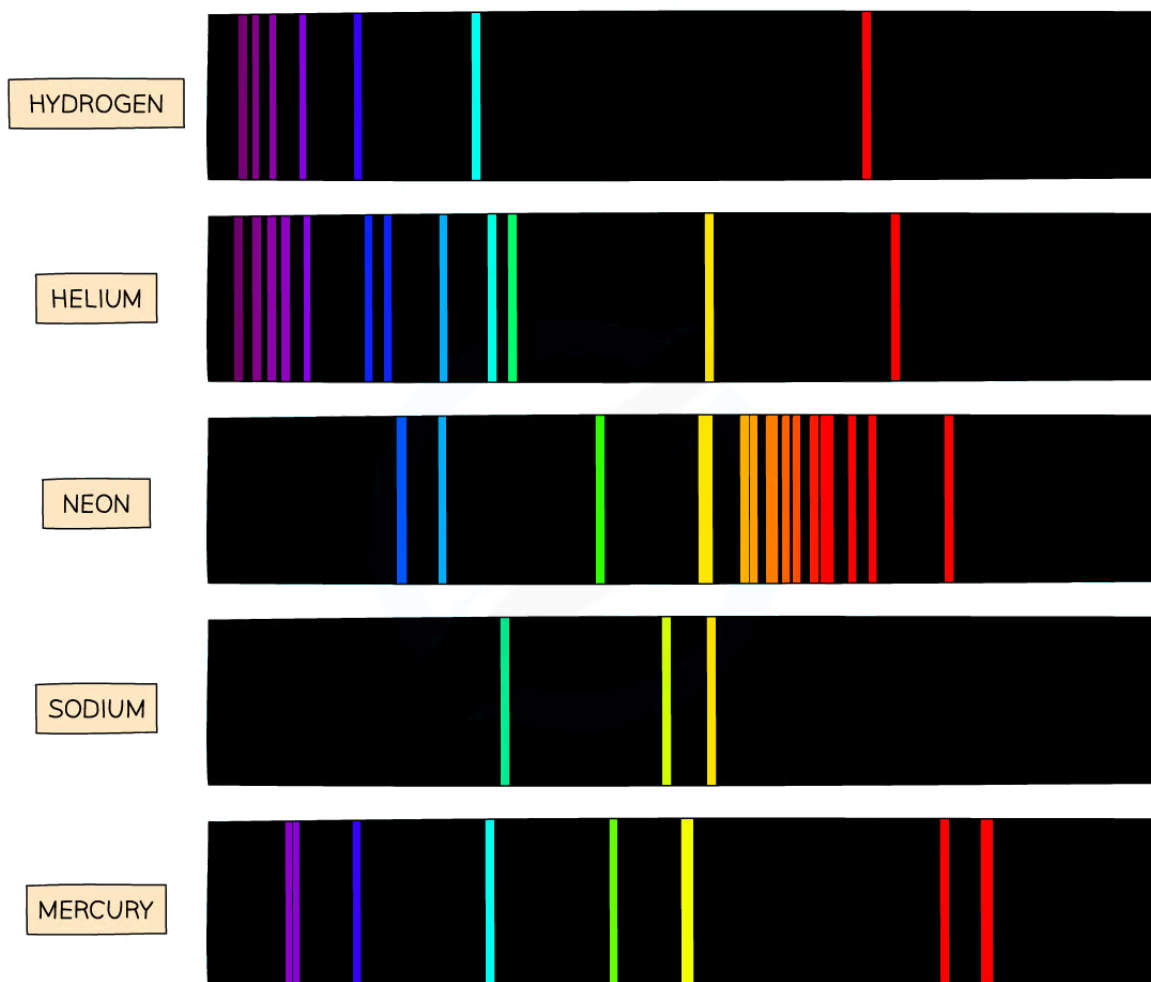

Copyright © Save My Exams. All Rights Reserved



**Emission line spectra are unique to each element, like a fingerprint**

- For example:
  - **Hydrogen** is known to produce strong spectral lines in the **red** portion of the visible spectrum, at **656 nm**

- When sodium is burned, a characteristic **yellow** flame is observed due to it producing strong spectral lines in the yellow portion of the spectrum, at **589 nm**
- When mercury is burned, most of the emission lines are below **450 nm**, which produces a characteristic **blue** light
- Elements such as **sodium** and **mercury** are known for their use in street lights, as well as **neon** for its use in colourful signs
- This can be achieved when
  - An electrical discharge is applied to the vapourised substance
  - The energy supplied excites orbital electrons within individual atoms to a higher energy state
  - When the electrons move back down to the ground state, a specific wavelength of light is emitted



Your notes



Your notes

## Photon Energy

### Photons & Atomic Transitions

#### The Photon Model

- Photons are fundamental particles that make up all forms of electromagnetic radiation
- A photon is defined as  
    **A massless “packet” or a “quantum” of electromagnetic energy**
- This means that the energy transferred by a photon is not continuous but as discrete packets of energy
  - In other words, each photon carries a specific amount of energy and transfers this energy all in one go
  - This is in contrast to waves which transfer energy continuously

#### Atomic Energy Levels

- Electrons in an atom occupy certain energy states called **energy levels**
  - Electrons will occupy the **lowest** possible energy level as this is the most **stable** configuration for the atom
  - When an electron **absorbs** or **emits** a photon, it can move between these energy levels, or be removed from the atom completely

#### Excitation

- When an electron moves to a higher energy level, the atom is said to be in an **excited state**
  - To **excite** an electron to a higher energy level, it must **absorb** a photon
- Electrons can also move back down to a lower energy level by **de-excitation**
  - To **de-excite** an electron to a lower energy level, it must **emit** a photon

#### Ionisation

- When an electron is removed from an atom, the atom becomes **ionised**
  - An electron can be removed from any energy level it occupies
  - However, the **ionisation energy** of an atom is the **minimum** energy required to remove an electron from the **ground state** of an atom

#### Representing Energy Levels

- Energy levels can be represented as a series of horizontal lines
  - The line at the bottom with the greatest negative energy represents the ground state
  - The lines above the ground state with decreasing energies represent excited states
  - The line at the top, usually 0 V or infinity  $\infty$ , represents the ionisation energy

#### Energy Levels in a Hydrogen Atom

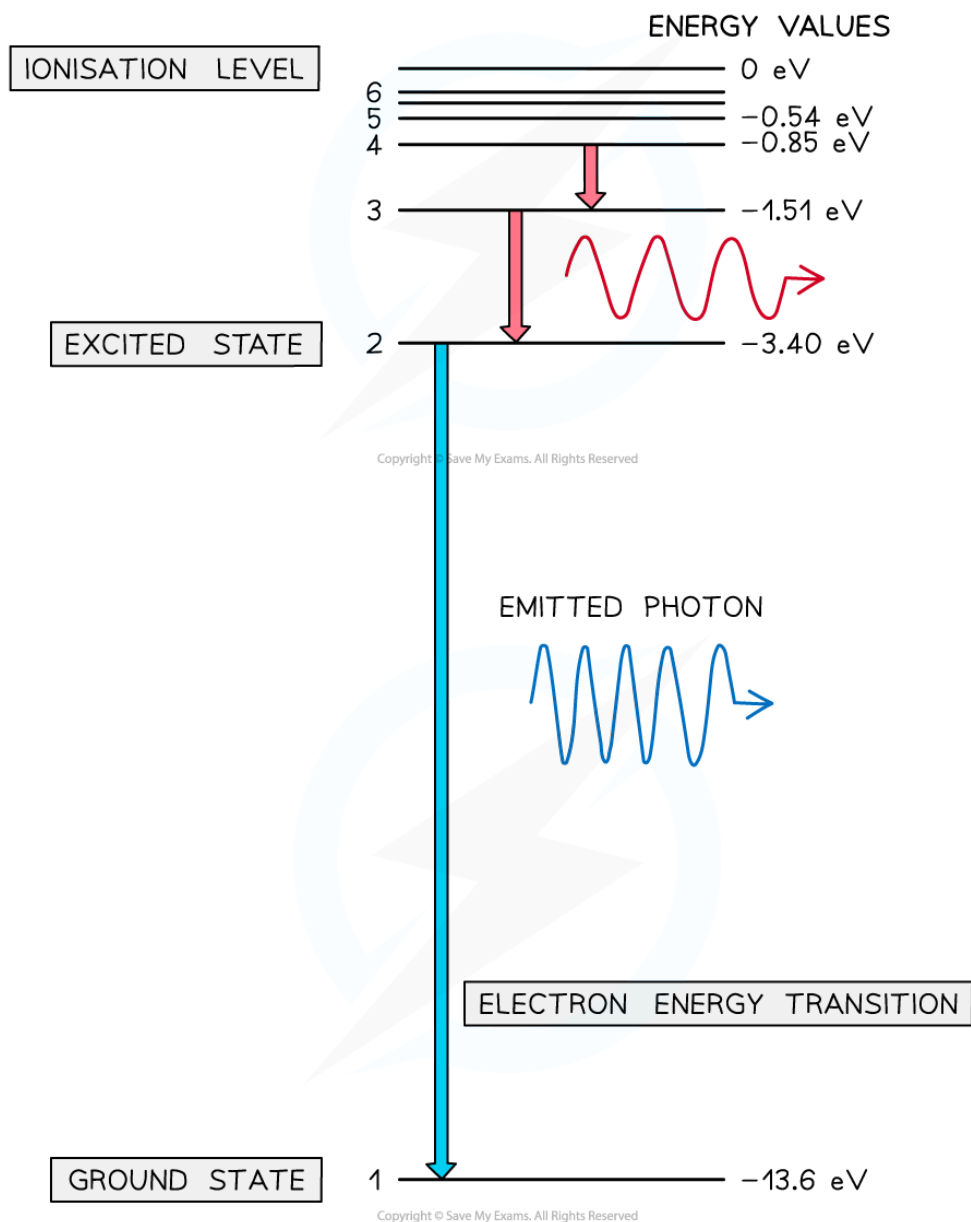

**A photon is emitted when an electron moves from a higher energy state to a lower energy state. The energy of the emitted photon is equal to the difference in energy between the energy levels in the transition.**



Your notes

### Worked example

Explain how atomic spectra provide evidence for the quantisation of energy in atoms.

**Answer:**

#### **Step 1: Outline the meaning of atomic spectra**

- Atomic spectra show the spectrum of discrete wavelengths emitted or absorbed by a specific atom

#### **Step 2: Describe the relationship between energy and wavelength**

- Photon energy is related to frequency and wavelength
- Therefore, photons with discrete wavelengths have discrete energies equal to the difference between two energy levels

#### **Step 3: Explain how atomic spectra give evidence for the quantisation of energy**

- Photons arise from electron transitions between energy levels
- This happens when an electron is excited, or de-excited, from one energy level to another, by either emitting or absorbing light of a specific wavelength
- Since atomic spectra are made up of discrete wavelengths, this shows that atoms must contain discrete, or quantised, energy levels



Your notes

### Worked example

The diagram shows the electron energy levels in an atom of hydrogen.

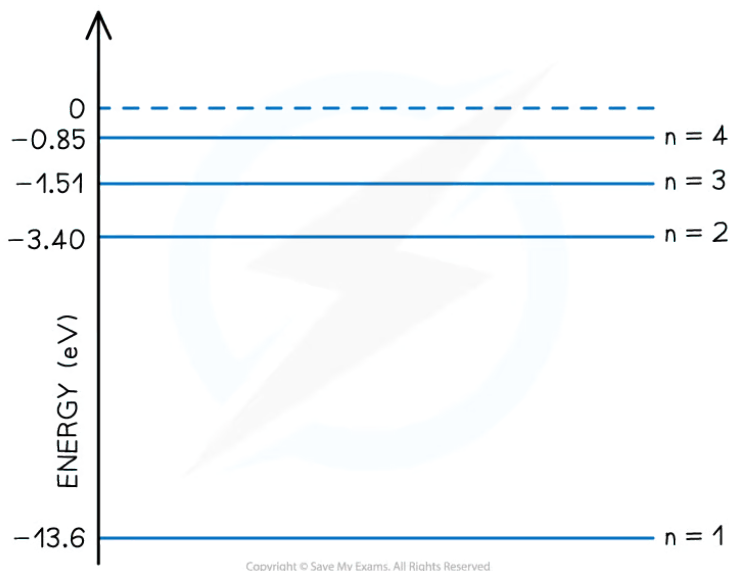

Determine the number of possible wavelengths that can be produced from transitions between the  $n = 4$  excited state and the  $n = 1$  ground state.

#### Answer:

- There are **six** possible wavelengths that could be produced from the different energy level transitions



Your notes

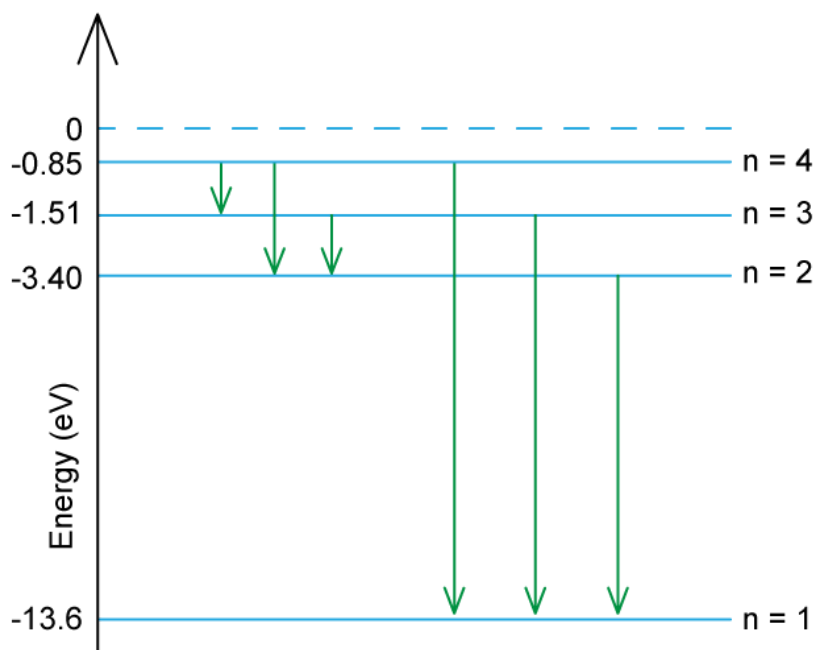

▪ The possible transitions are:

- n = 4 to n = 3
- n = 4 to n = 2
- n = 4 to n = 1
- n = 3 to n = 2
- n = 3 to n = 1
- n = 2 to n = 1

### Examiner Tip

Make sure you learn the definition for a photon: *discrete quantity / packet / quantum of electromagnetic energy* are all acceptable definitions





Your notes

## Calculating Photon Energy

- Each line of the emission spectrum corresponds to a different **energy level transition** within the atom
  - Electrons can transition between energy levels absorbing or emitting a **discrete amount of energy**
  - An excited electron can transition down to the next energy level or move to a further level closer to the ground state
- For example, if an atom has **six** energy levels:
  - At low temperatures, most electrons will occupy the ground state  $n = 1$
  - At high temperatures, electrons may be excited to the most excited state  $n = 6$



$$E = hf$$

Copyright © Save My Exams. All Rights Reserved

**Energy and frequency of a photon are directly proportional**

- The energy of a photon can be calculated using the formula:

$$E = hf$$

- Using the wave equation, energy can also be equal to:

$$E = \frac{hc}{\lambda}$$

- Where:
  - $E$  = energy of the photon (J)
  - $h$  = Planck's constant (J s)
  - $c$  = the speed of light ( $\text{m s}^{-1}$ )
  - $f$  = frequency (Hz)
  - $\lambda$  = wavelength (m)
- This equation tells us:
  - The higher the frequency of EM radiation, the higher the energy of the photon
  - The energy of a photon is inversely proportional to the wavelength
  - A long-wavelength photon of light has a lower energy than a shorter-wavelength photon

## Difference in discrete energy levels

- The difference between two energy levels is equal to a specific photon energy

- The energy of the photon is given by:

$$\Delta E = hf = E_2 - E_1$$

- Where:

- $E_1$  = energy of the lower level (J)
- $E_2$  = energy of the higher level (J)

- Using the wave equation, the wavelength of the emitted, or absorbed, radiation can be related to the energy difference by the equation:

$$\lambda = \frac{hc}{E_2 - E_1}$$

- This equation shows that:

- The larger the difference in energy between two levels  $\Delta E$ , the shorter the wavelength  $\lambda$  and vice versa



Your notes



Your notes

### Worked example

Some electron energy levels in atomic hydrogen are shown below.

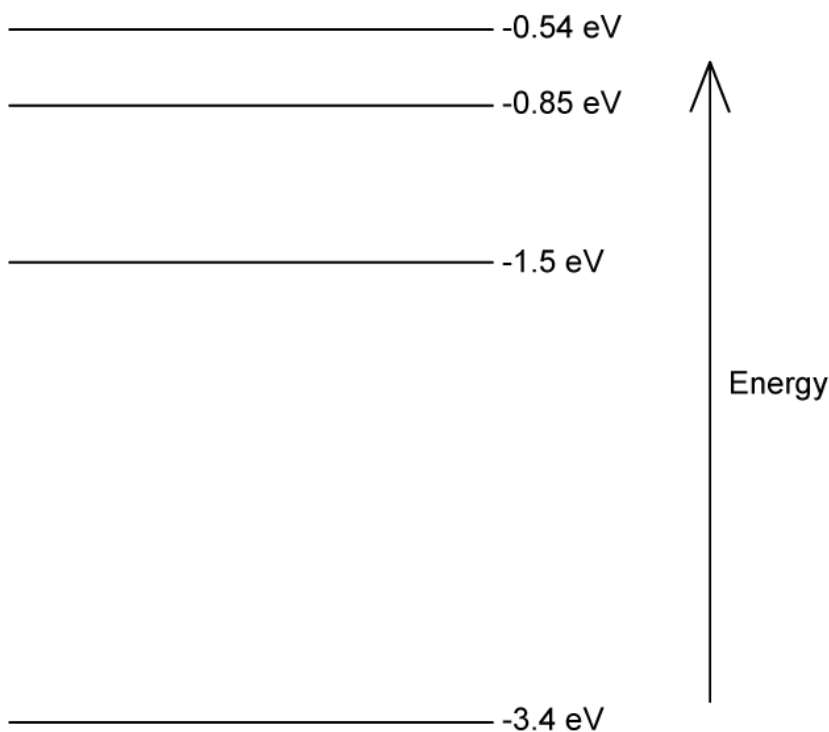

The longest wavelength produced as a result of electron transitions between two of the energy levels is  $4.0 \times 10^{-6}$  m.

- (a) Draw an arrow to show the transition that would produce:
- A photon of wavelength  $4.0 \times 10^{-6}$  m. Mark with the letter **L**.
  - The photon with the shortest wavelength. Mark with the letter **S**.
- (b) Calculate the wavelength for the transition giving rise to the shortest wavelength.

**Answer:**

- (a)
- Photon energy and wavelength are inversely proportional
  - Therefore, the largest energy change corresponds to the shortest wavelength (line **S**)
  - The smallest energy change corresponds to the longest wavelength (line **L**)



Your notes

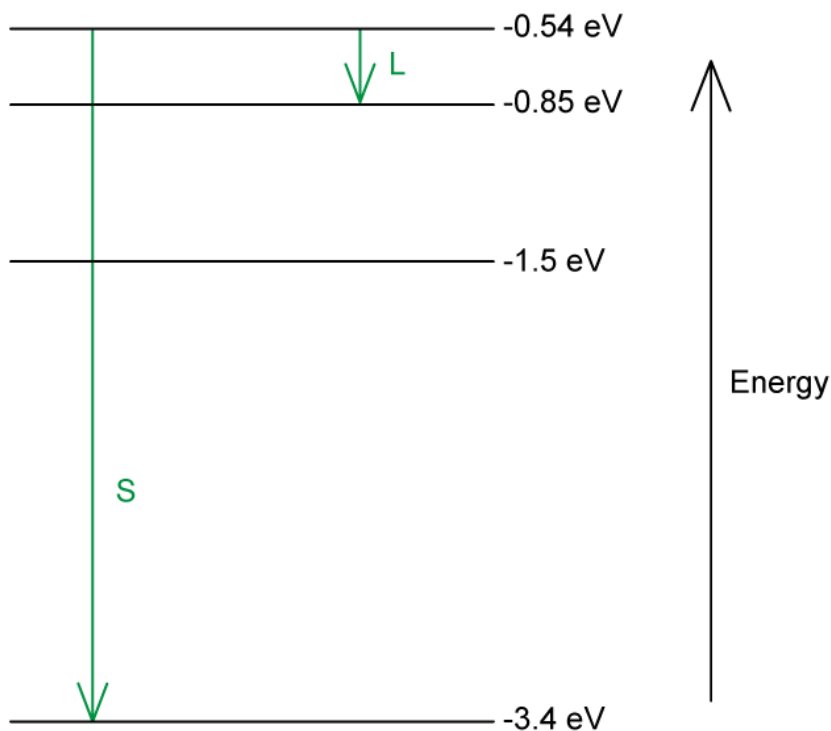

(b)

**Step 1: Write down the equation linking wavelength and energy**

$$\lambda = \frac{hc}{\Delta E} = \frac{hc}{E_2 - E_1}$$

**Step 2: Identify the energy levels that give rise to the shortest wavelength**

- The shortest wavelength photon will come from a transition between the energy levels that have the largest difference:

- $E_2 = -0.54 \text{ eV}$

- $E_1 = -3.4 \text{ eV}$

- Therefore, the greatest possible difference in energy is

$$\Delta E = E_2 - E_1 = -0.54 - (-3.4) = 2.86 \text{ eV}$$

**Step 3: Calculate the wavelength**

- To convert from eV to J: multiply by  $1.6 \times 10^{-19} \text{ J}$

$$\lambda = \frac{(6.63 \times 10^{-34})(3.0 \times 10^8)}{2.86 \times (1.6 \times 10^{-19})}$$

$$\lambda = 4.347 \times 10^{-7} \text{ m} = 435 \text{ nm}$$



Your notes

### Worked example

Light of wavelength 490 nm is incident normally on a surface, as shown in the diagram.

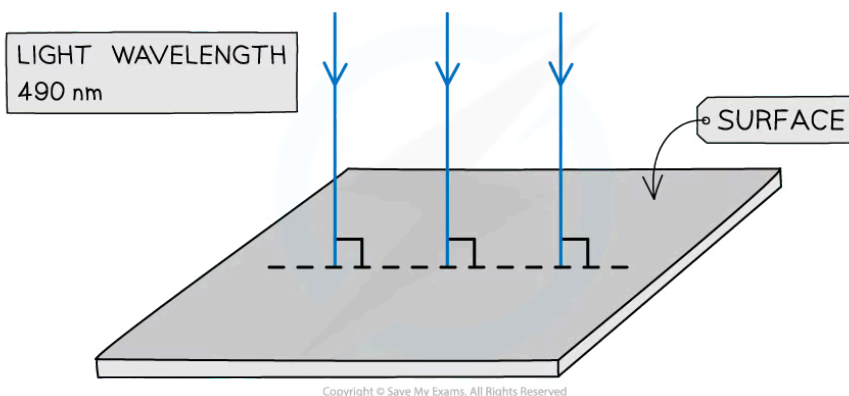

The power of the light is 3.6 mW. The light is completely absorbed by the surface.

Calculate the number of photons incident on the surface in 30 s.

**Answer:**

**Step 1: Write down the known quantities**

- Wavelength,  $\lambda = 490 \text{ nm} = 490 \times 10^{-9} \text{ m}$
- Power,  $P = 3.6 \text{ mW} = 3.6 \times 10^{-3} \text{ W}$
- Time,  $t = 30 \text{ s}$

**Step 2: Write the equation for photon energy and write in terms of wavelength**

$$E = hf \quad \Rightarrow \quad E = \frac{hc}{\lambda}$$

**Step 3: Calculate the energy of one photon**

$$E = \frac{hc}{\lambda} = \frac{(6.63 \times 10^{-34})(3.0 \times 10^8)}{490 \times 10^{-9}} = 4.06 \times 10^{-19} \text{ J}$$

**Step 4: Calculate the number of photons hitting the surface every second**

$$\frac{\text{power of light source}}{\text{energy of one photon}} = \frac{3.6 \times 10^{-3}}{4.06 \times 10^{-19}} = 8.87 \times 10^{15} \text{ s}^{-1}$$

**Step 5: Calculate the number of photons that hit the surface in 30 s**

$$\text{number of photons in 30 s} = (8.87 \times 10^{15}) \times 30 = 2.7 \times 10^{17}$$



Your notes

### Examiner Tip

The values of Planck's constant and the speed of light will be included in the data booklet, however, it helps to memorise them to speed up calculations!