

HL IB Physics



Your notes

Structure of the Atom

Contents

- * Rutherford's Gold Foil Experiment
- * Nuclear Notation
- * Emission & Absorption Spectrum
- * Photon Energy
- * Rutherford Scattering & Nuclear Radius (HL)
- * Deviations from Rutherford Scattering (HL)
- * The Bohr Model of Hydrogen (HL)



Your notes

Rutherford's Gold Foil Experiment

Rutherford's Gold Foil Experiment

- Evidence for the structure of the atom was discovered by Ernest Rutherford at the beginning of the 20th century from the study of **alpha particle scattering**
- The experiment consisted of beams of high-energy alpha particles fired at thin gold foil and a detector on the other side to determine
 - The different **angles of deflection** of the alpha particles
 - The **number of alpha particles** that were deflected at each angle

Apparatus for the Rutherford Scattering Experiment

- The setup for the scattering experiment consisted of:
 - A source of alpha particles in a lead container
 - A thin sheet of gold foil
 - A movable detector
 - An evacuated chamber

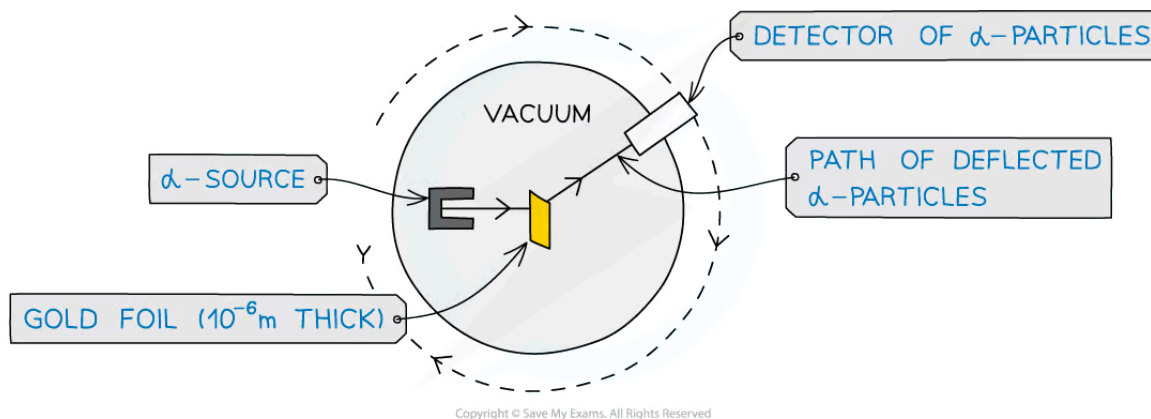

Experimental set up for α-particle scattering

Purpose of the lead container

- Alpha particles are emitted in all directions, so the source was placed in a **lead container**
- This was to produce a collimated beam of alpha particles
- This is because alpha particles are absorbed by lead, so a long narrow hole at the front allowed a concentrated beam of alpha particles to escape and be directed as needed

Purpose of the thin sheet of gold foil

- The target material needed to be **extremely thin**, about 10⁻⁶ m thick
- This is because a thicker foil would stop the alpha particles completely
- Gold was chosen due to its malleability, meaning it was easy to hammer into thin sheets

Purpose of the evacuated chamber

- Alpha particles are highly ionising, meaning they only travel about 5 cm before interacting with molecules of air
- So, the apparatus was placed in an **evacuated chamber**
- This was to ensure that the alpha particles did not collide with any particles on their way to the foil target

Findings from the Rutherford Scattering Experiment

- An alpha (α) particle is the nucleus of a helium atom, so it has a **positive** charge

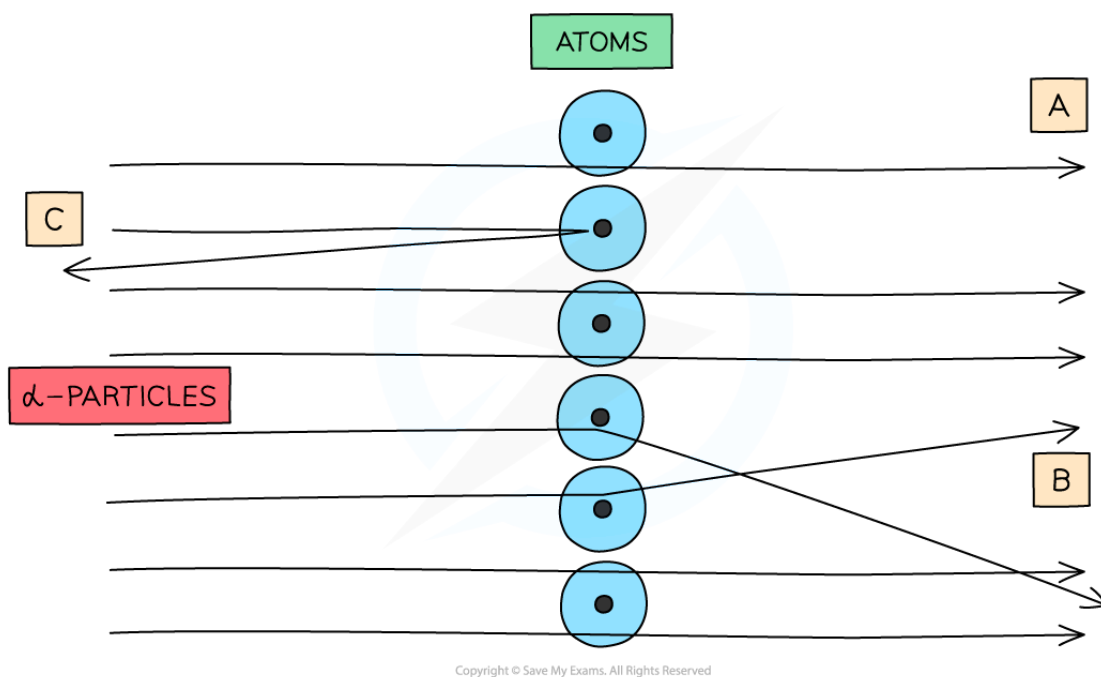

When α -particles are fired at thin gold foil, most of them go straight through but a small number bounce straight back

- The observations from Rutherford's experiment were:
 - The majority of α -particles passed straight through the foil undeflected**
 - This suggests the atom is mostly empty space
 - Some α -particles deflected through small angles of $<10^\circ$**
 - This suggests there is a positive nucleus at the centre (since two positive charges would repel)
 - Only a small number of α -particles deflected straight back at angles of $>90^\circ$**
 - This suggests the nucleus is extremely small and is where most of the mass and charge of the atom are concentrated
 - This led to the conclusion that atoms consist of small, dense positively charged nuclei surrounded by negatively charged electrons

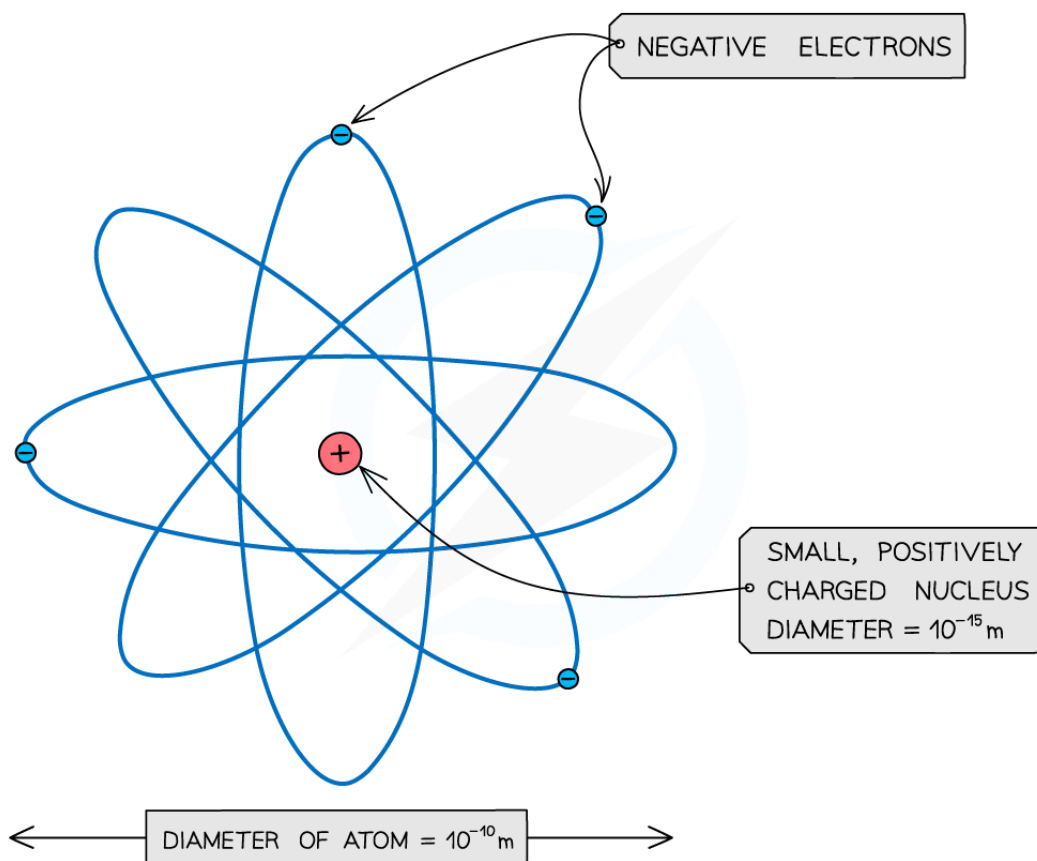

Copyright © Save My Exams. All Rights Reserved

An atom: a small positive nucleus, surrounded by negative electrons

- (Note: The atom is around 100,000 times larger than the nucleus!)



Your notes

Worked example

In an α -particle scattering experiment, a student set up the apparatus below to determine the number of α -particles, n , incident per unit time on a detector held at various angles θ .

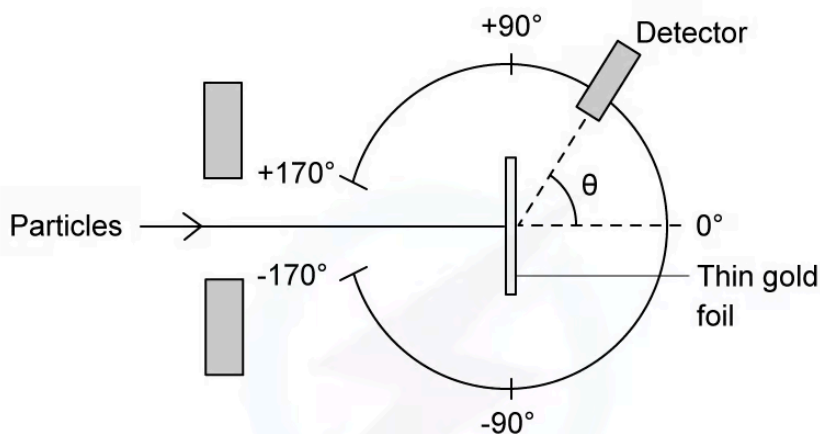

Which of the following graphs best represents the variation of n with θ from 0 to 90°?

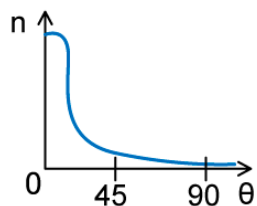
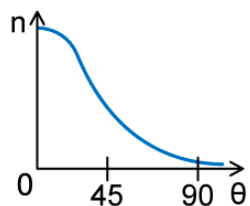
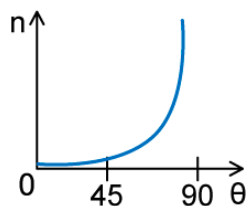
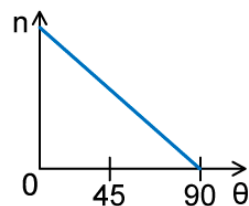
A.

B.

C.

D.

Answer: A

- The Rutherford scattering experiment directed parallel beams of α -particles at gold foil
- The observations were:
 - Most of the α -particles went straight through the foil
 - The largest value of n will therefore be at small angles
 - Some of the α -particles were deflected through small angles
 - n drops quickly with increasing angle of deflection θ
- These observations fit with graph A



Your notes

Nuclear Notation

Nuclear Notation

- All matter is made from **atoms**
- Atoms are made up of three subatomic particles:
 - Protons
 - Neutrons
 - Electrons

Structure of the Atom

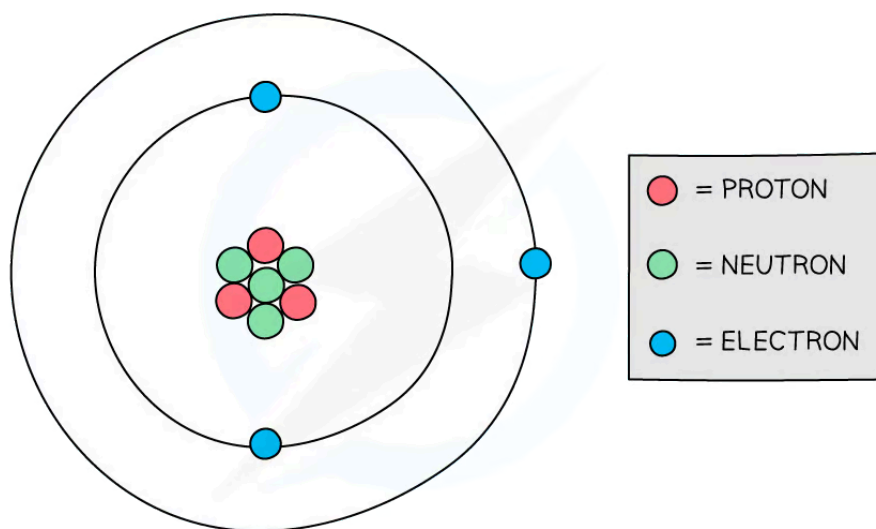

Copyright © Save My Exams. All Rights Reserved

Protons and neutrons are found in the nucleus of an atom while electrons orbit the nucleus

- Each of these subatomic particles has a **mass** and a **charge**
 - Charge can be expressed in coulombs (C), or units of elementary charge e
 - Mass can be expressed in kilograms (kg), or in atomic mass units u

Table of properties of subatomic particles

particle	charge / C	charge / e	mass / kg	mass / u
proton	$+1.60 \times 10^{-19}$	+1	1.673×10^{-27}	1.007276

neutron	0	0	1.675×10^{-27}	1.008665
electron	-1.60×10^{-19}	-1	9.109×10^{-31}	0.000549

- A nucleus can be described using $\frac{A}{Z}X$ notation

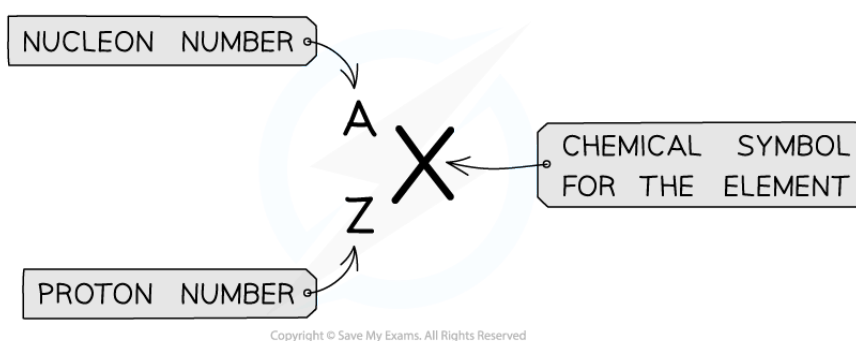

$\frac{A}{Z}X$ notation is used to describe the constituents of a nucleus

- The top number A represents the **nucleon** number or the **mass** number
 - Nucleon number (A)** = total number of **protons and neutrons** in the nucleus
- The lower number Z represents the **proton** or **atomic** number
 - Proton number (Z)** = total number of **protons** in the nucleus

Examiner Tip

In Chemistry, you may see nucleon number referred to as mass number and proton number as atomic number. Both of these are valid, just make sure you don't mistake mass number for atomic number, or vice versa.

Make sure you know that the periodic table is ordered by **atomic number**



Your notes

Emission & Absorption Spectrum

Spectra & Atomic Energy Levels

- Atomic spectra are observed when atoms **emit** or **absorb** light of certain wavelengths
 - These are known as **emission spectra** and **absorption spectra**
- Atomic spectra provide **evidence** that electrons in atoms can only transition between discrete atomic energy levels

Emission Spectra

- Emission spectra can be produced by heating a low-pressure gas
 - Heating provides energy to **excite** electrons to higher energy levels
 - When an electron transitions back to a **lower** energy level, it **emits** a photon
- Each transition corresponds to a **specific wavelength** of light which correlates to an observable spectral line
- The resulting **emission spectrum** contains a set of discrete wavelengths, represented by coloured lines on a black background

Emission spectrum of hydrogen gas

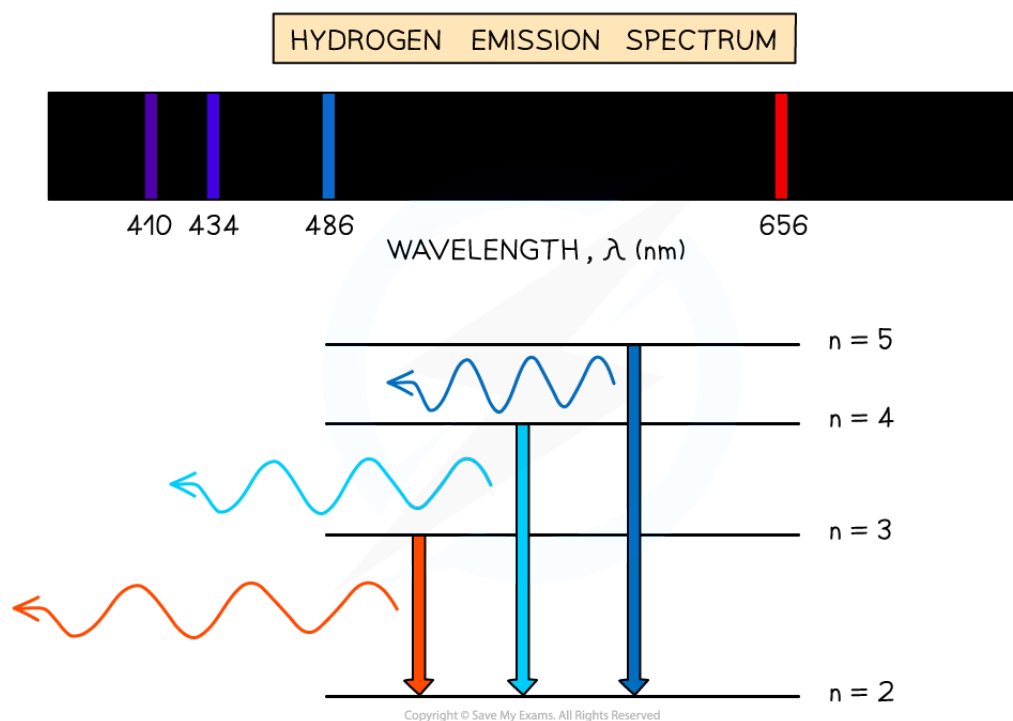

A typical hydrogen emission spectrum contains several spectral lines in the visible region of the electromagnetic spectrum



Your notes

Absorption Spectra

- Absorption spectra can be produced by passing white light through a **cool, low-pressure gas**
 - Only photons with the exact energy required to excite electrons will be absorbed
- Each absorbed photon corresponds to a **specific wavelength** of light which correlates to an observable dark line in a continuous spectrum of wavelengths
- The resulting **absorption spectrum** contains a set of discrete wavelengths, represented by dark lines on a coloured background
 - These lines correspond to the same lines observed on an emission spectrum for the **same** element

Absorption spectrum of hydrogen gas

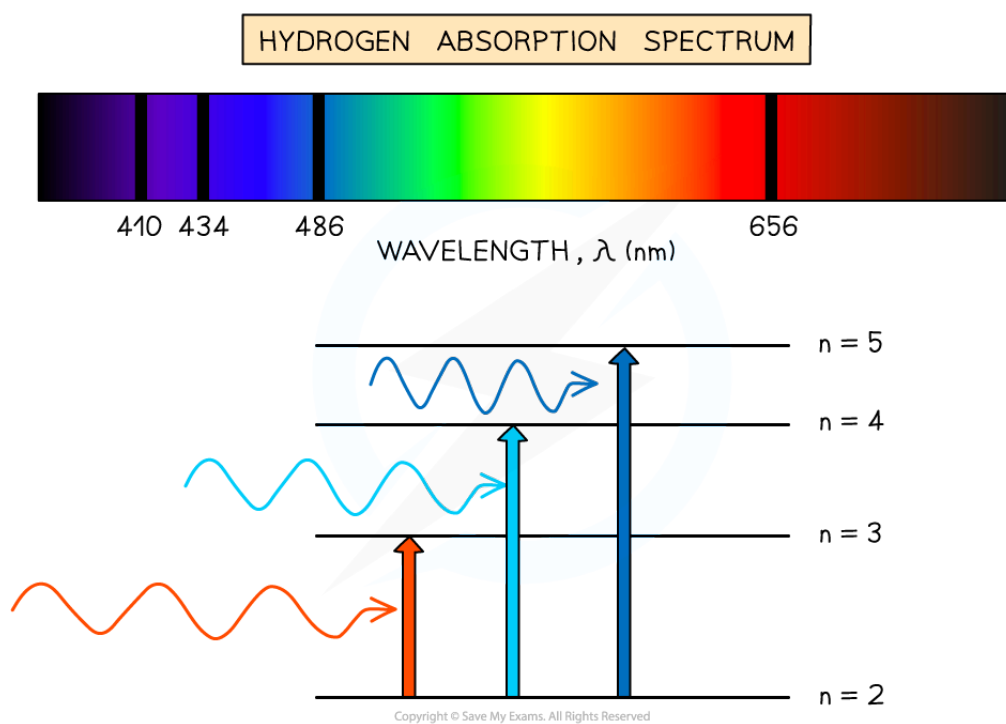

A typical hydrogen absorption spectrum is the inverse of its emission spectrum

Spectra & Chemical Composition

- The **chemical composition** of a substance can be investigated using emission and absorption spectra
- Each element produces a unique pattern of spectral lines
- No two elements produce the same set of spectral lines, therefore, elements can be identified by their atomic spectrum

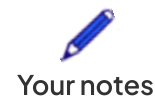

Emission spectra of different elements

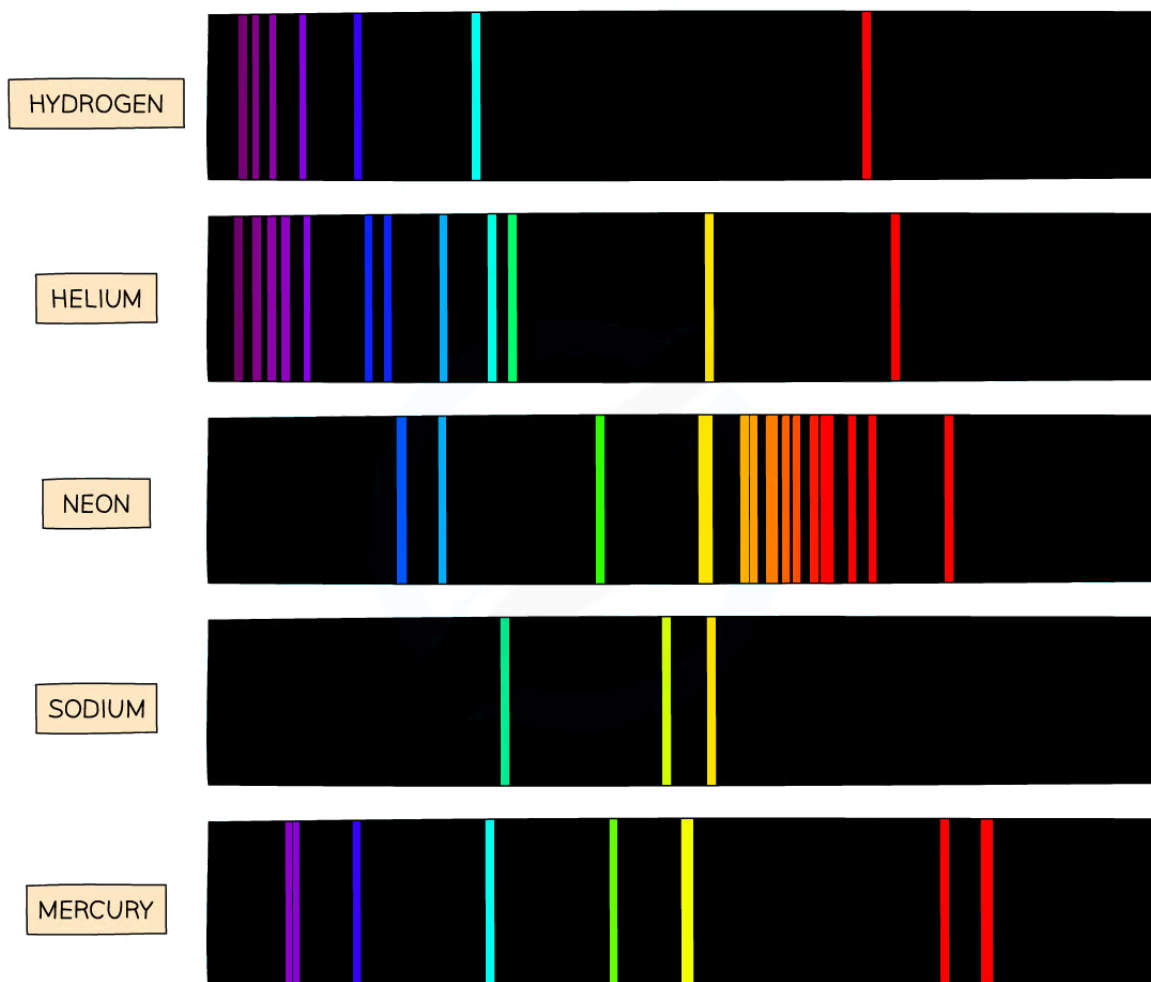

Copyright © Save My Exams. All Rights Reserved



Emission line spectra are unique to each element, like a fingerprint

- For example:
 - **Hydrogen** is known to produce strong spectral lines in the **red** portion of the visible spectrum, at **656 nm**

- When sodium is burned, a characteristic **yellow** flame is observed due to it producing strong spectral lines in the yellow portion of the spectrum, at **589 nm**
- When mercury is burned, most of the emission lines are below **450 nm**, which produces a characteristic **blue** light
- Elements such as **sodium** and **mercury** are known for their use in street lights, as well as **neon** for its use in colourful signs
- This can be achieved when
 - An electrical discharge is applied to the vapourised substance
 - The energy supplied excites orbital electrons within individual atoms to a higher energy state
 - When the electrons move back down to the ground state, a specific wavelength of light is emitted



Your notes



Your notes

Photon Energy

Photons & Atomic Transitions

The Photon Model

- Photons are fundamental particles that make up all forms of electromagnetic radiation
- A photon is defined as
 - A massless “packet” or a “quantum” of electromagnetic energy
- This means that the energy transferred by a photon is not continuous but as discrete packets of energy
 - In other words, each photon carries a specific amount of energy and transfers this energy all in one go
 - This is in contrast to waves which transfer energy continuously

Atomic Energy Levels

- Electrons in an atom occupy certain energy states called **energy levels**
 - Electrons will occupy the **lowest** possible energy level as this is the most **stable** configuration for the atom
 - When an electron **absorbs** or **emits** a photon, it can move between these energy levels, or be removed from the atom completely

Excitation

- When an electron moves to a higher energy level, the atom is said to be in an **excited state**
 - To **excite** an electron to a higher energy level, it must **absorb** a photon
- Electrons can also move back down to a lower energy level by **de-excitation**
 - To **de-excite** an electron to a lower energy level, it must **emit** a photon

Ionisation

- When an electron is removed from an atom, the atom becomes **ionised**
 - An electron can be removed from any energy level it occupies
 - However, the **ionisation energy** of an atom is the **minimum** energy required to remove an electron from the **ground state** of an atom

Representing Energy Levels

- Energy levels can be represented as a series of horizontal lines
 - The line at the bottom with the greatest negative energy represents the ground state
 - The lines above the ground state with decreasing energies represent excited states
 - The line at the top, usually 0 V or infinity ∞ , represents the ionisation energy

Energy Levels in a Hydrogen Atom

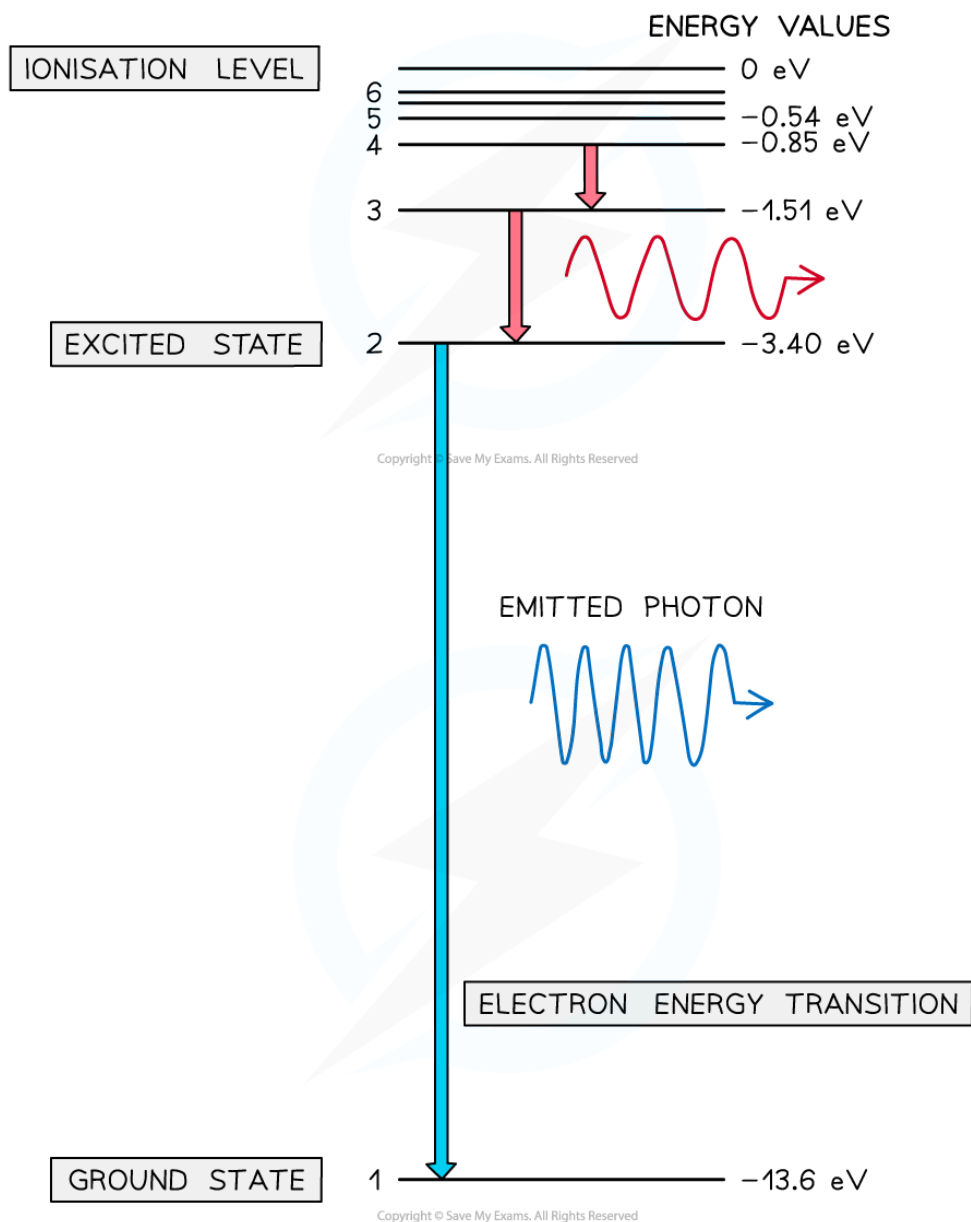

A photon is emitted when an electron moves from a higher energy state to a lower energy state. The energy of the emitted photon is equal to the difference in energy between the energy levels in the transition.



Your notes

Worked example

Explain how atomic spectra provide evidence for the quantisation of energy in atoms.

Answer:

Step 1: Outline the meaning of atomic spectra

- Atomic spectra show the spectrum of discrete wavelengths emitted or absorbed by a specific atom

Step 2: Describe the relationship between energy and wavelength

- Photon energy is related to frequency and wavelength
- Therefore, photons with discrete wavelengths have discrete energies equal to the difference between two energy levels

Step 3: Explain how atomic spectra give evidence for the quantisation of energy

- Photons arise from electron transitions between energy levels
- This happens when an electron is excited, or de-excited, from one energy level to another, by either emitting or absorbing light of a specific wavelength
- Since atomic spectra are made up of discrete wavelengths, this shows that atoms must contain discrete, or quantised, energy levels



Your notes

Worked example

The diagram shows the electron energy levels in an atom of hydrogen.

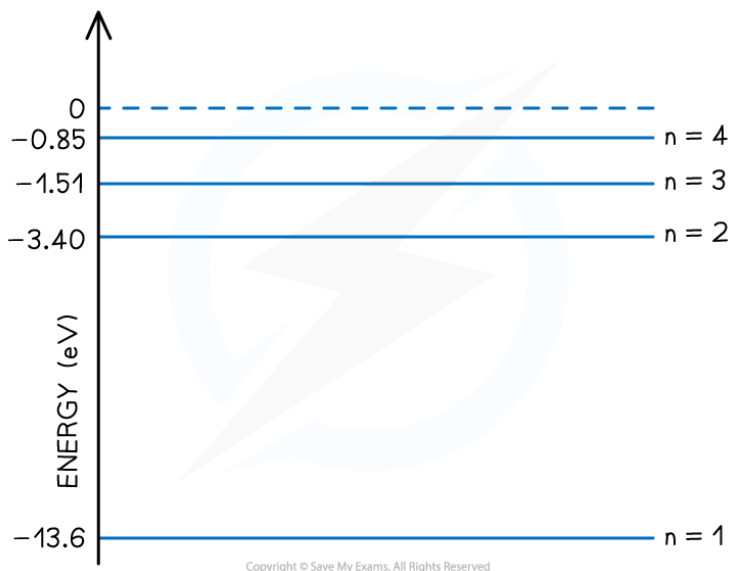

Determine the number of possible wavelengths that can be produced from transitions between the $n = 4$ excited state and the $n = 1$ ground state.

Answer:

- There are **six** possible wavelengths that could be produced from the different energy level transitions



Your notes

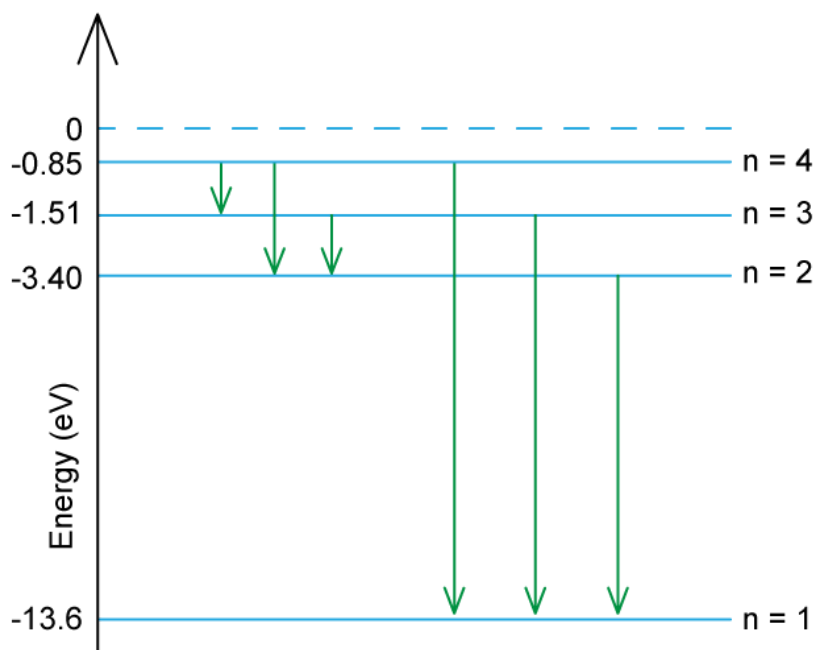

▪ The possible transitions are:

- $n = 4$ to $n = 3$
- $n = 4$ to $n = 2$
- $n = 4$ to $n = 1$
- $n = 3$ to $n = 2$
- $n = 3$ to $n = 1$
- $n = 2$ to $n = 1$

 **Examiner Tip**

Make sure you learn the definition for a photon: *discrete quantity / packet / quantum of electromagnetic energy* are all acceptable definitions



Your notes

Calculating Photon Energy

- Each line of the emission spectrum corresponds to a different **energy level transition** within the atom
 - Electrons can transition between energy levels absorbing or emitting a **discrete amount of energy**
 - An excited electron can transition down to the next energy level or move to a further level closer to the ground state
- For example, if an atom has **six** energy levels:
 - At low temperatures, most electrons will occupy the ground state $n = 1$
 - At high temperatures, electrons may be excited to the most excited state $n = 6$



$$E = hf$$

Copyright © Save My Exams. All Rights Reserved

Energy and frequency of a photon are directly proportional

- The energy of a photon can be calculated using the formula:

$$E = hf$$

- Using the wave equation, energy can also be equal to:

$$E = \frac{hc}{\lambda}$$

- Where:
 - E = energy of the photon (J)
 - h = Planck's constant (J s)
 - c = the speed of light (m s^{-1})
 - f = frequency (Hz)
 - λ = wavelength (m)
- This equation tells us:
 - The higher the frequency of EM radiation, the higher the energy of the photon
 - The energy of a photon is inversely proportional to the wavelength
 - A long-wavelength photon of light has a lower energy than a shorter-wavelength photon

Difference in discrete energy levels

- The difference between two energy levels is equal to a specific photon energy

- The energy of the photon is given by:

$$\Delta E = hf = E_2 - E_1$$

- Where:

- E_1 = energy of the lower level (J)
- E_2 = energy of the higher level (J)

- Using the wave equation, the wavelength of the emitted, or absorbed, radiation can be related to the energy difference by the equation:

$$\lambda = \frac{hc}{E_2 - E_1}$$

- This equation shows that:

- The larger the difference in energy between two levels ΔE , the shorter the wavelength λ and vice versa



Your notes



Your notes

Worked example

Some electron energy levels in atomic hydrogen are shown below.

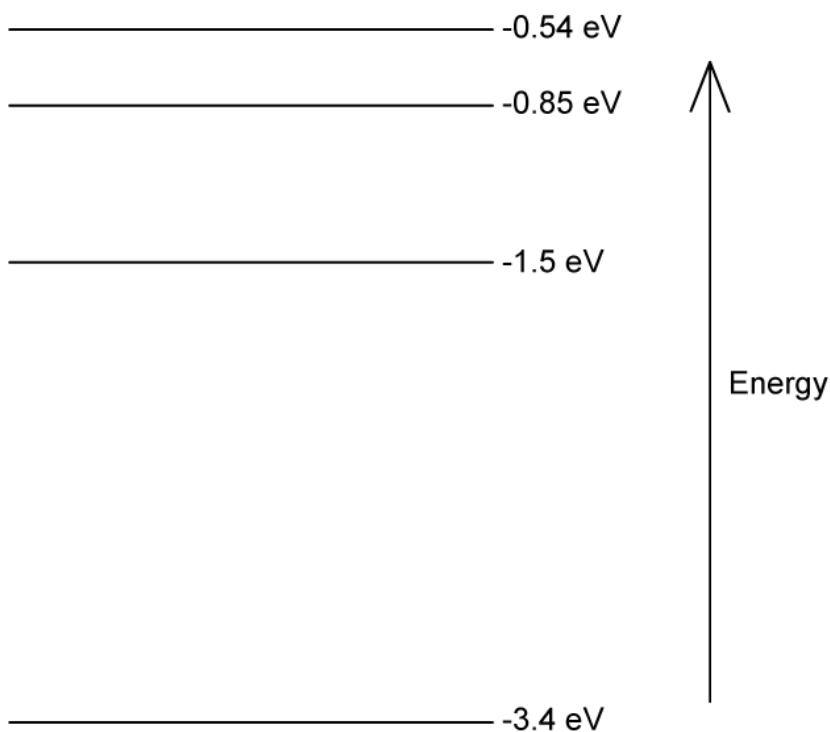

The longest wavelength produced as a result of electron transitions between two of the energy levels is 4.0×10^{-6} m.

- (a) Draw an arrow to show the transition that would produce:
- A photon of wavelength 4.0×10^{-6} m. Mark with the letter **L**.
 - The photon with the shortest wavelength. Mark with the letter **S**.
- (b) Calculate the wavelength for the transition giving rise to the shortest wavelength.

Answer:

- (a)
- Photon energy and wavelength are inversely proportional
 - Therefore, the largest energy change corresponds to the shortest wavelength (line **S**)
 - The smallest energy change corresponds to the longest wavelength (line **L**)



Your notes

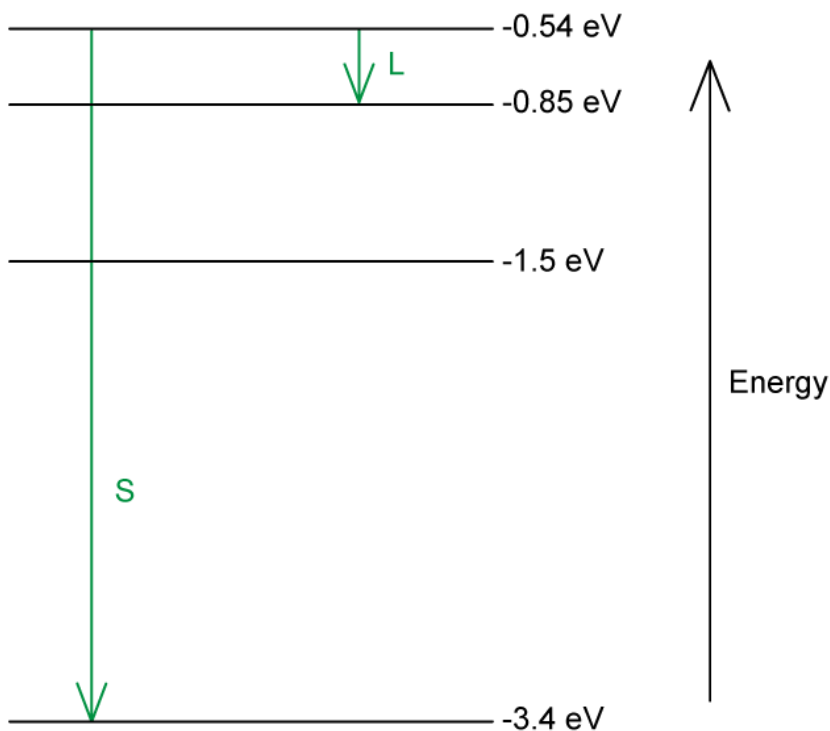

(b)

Step 1: Write down the equation linking wavelength and energy

$$\lambda = \frac{hc}{\Delta E} = \frac{hc}{E_2 - E_1}$$

Step 2: Identify the energy levels that give rise to the shortest wavelength

- The shortest wavelength photon will come from a transition between the energy levels that have the largest difference:

- $E_2 = -0.54 \text{ eV}$

- $E_1 = -3.4 \text{ eV}$

- Therefore, the greatest possible difference in energy is

$$\Delta E = E_2 - E_1 = -0.54 - (-3.4) = 2.86 \text{ eV}$$

Step 3: Calculate the wavelength

- To convert from eV to J: multiply by $1.6 \times 10^{-19} \text{ J}$

$$\lambda = \frac{(6.63 \times 10^{-34})(3.0 \times 10^8)}{2.86 \times (1.6 \times 10^{-19})}$$

$$\lambda = 4.347 \times 10^{-7} \text{ m} = 435 \text{ nm}$$



Your notes

Worked example

Light of wavelength 490 nm is incident normally on a surface, as shown in the diagram.

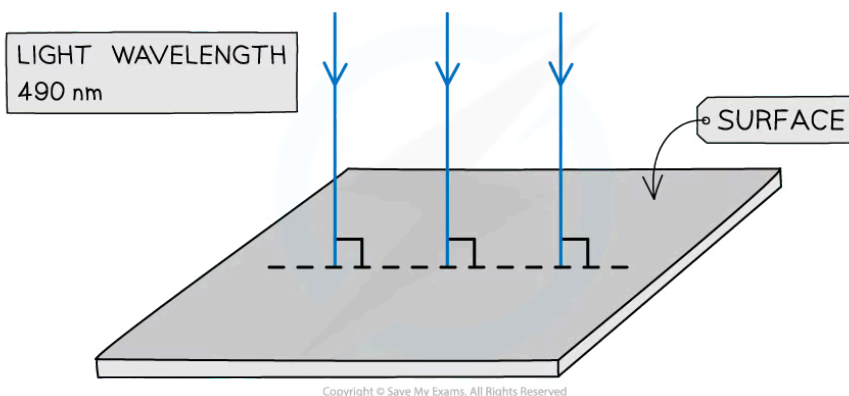

The power of the light is 3.6 mW. The light is completely absorbed by the surface.

Calculate the number of photons incident on the surface in 30 s.

Answer:

Step 1: Write down the known quantities

- Wavelength, $\lambda = 490 \text{ nm} = 490 \times 10^{-9} \text{ m}$
- Power, $P = 3.6 \text{ mW} = 3.6 \times 10^{-3} \text{ W}$
- Time, $t = 30 \text{ s}$

Step 2: Write the equation for photon energy and write in terms of wavelength

$$E = hf \quad \Rightarrow \quad E = \frac{hc}{\lambda}$$

Step 3: Calculate the energy of one photon

$$E = \frac{hc}{\lambda} = \frac{(6.63 \times 10^{-34})(3.0 \times 10^8)}{490 \times 10^{-9}} = 4.06 \times 10^{-19} \text{ J}$$

Step 4: Calculate the number of photons hitting the surface every second

$$\frac{\text{power of light source}}{\text{energy of one photon}} = \frac{3.6 \times 10^{-3}}{4.06 \times 10^{-19}} = 8.87 \times 10^{15} \text{ s}^{-1}$$

Step 5: Calculate the number of photons that hit the surface in 30 s

$$\text{number of photons in 30 s} = (8.87 \times 10^{15}) \times 30 = 2.7 \times 10^{17}$$

 **Examiner Tip**

The values of Planck's constant and the speed of light will be included in the data booklet, however, it helps to memorise them to speed up calculations!



Your notes



Your notes

Rutherford Scattering & Nuclear Radius (HL)

Nuclear Radius

- The radius of a nucleus depends on the nucleon number A of the atom
 - The greater the number of nucleons a nucleus has, the greater the space the nucleus occupies, hence giving it a larger radius
- The exact relationship between the **radius** and **nucleon number** can be determined from experimental data, such as Rutherford scattering
- By doing this, physicists were able to deduce the following relationship:

$$R = R_0 A^{\frac{1}{3}}$$

- Where:
 - R = nuclear radius (m)
 - A = nucleon / mass number
 - R_0 = Fermi radius
- The constant of proportionality $R_0 = 1.20 \times 10^{-15}$ m is known as the **Fermi radius**
- This is the radius of a hydrogen nucleus which contains only one proton ($A = 1$)

Nuclear Density

- Assuming that the nucleus is spherical, its volume is equal to:

$$V = \frac{4}{3} \pi R^3$$

- Combining this with the expression for nuclear radius gives:

$$V = \frac{4}{3} \pi \left(R_0 A^{\frac{1}{3}} \right)^3 = \frac{4}{3} \pi R_0^3 A$$

- This tells us that the nuclear volume V is proportional to the mass of the nucleus m , which is equal to

$$m = Au$$

- Where u = atomic mass unit (kg)
- Using the definition for density, nuclear density is equal to:

$$\rho = \frac{m}{V}$$

$$\rho = \frac{Au}{\frac{4}{3} \pi R_0^3 A} = \frac{3u}{4\pi R_0^3}$$



Your notes

- Since the mass number A cancels out, the remaining quantities in the equation are all **constants**
- Therefore, this shows the density of the nucleus is:
 - The **same** for all nuclei
 - Independent of the **radius**
- The fact that nuclear density is constant shows that nucleons are **evenly separated** throughout the nucleus regardless of their size
- The accuracy of nuclear density depends on the accuracy of the constant R_0
 - As a guide, nuclear density should always be of the order $10^{17} \text{ kg m}^{-3}$
- Nuclear density is significantly **larger** than atomic density which suggests:
 - The **majority** of the atom's mass is contained in the nucleus
 - The nucleus is very **small** compared to the atom
 - Atoms must be predominantly **empty space**

Worked example

Determine the value of nuclear density.

You may take the constant of proportionality R_0 to be 1.20 fm.

Answer:

Step 1: Derive an expression for nuclear density

- Using the equation derived above, the density of the nucleus is:

$$\rho = \frac{3u}{4\pi R_0^3}$$

Step 2: List the known quantities

- Atomic mass unit, $u = 1.661 \times 10^{-27} \text{ kg}$
- Constant of proportionality, $R_0 = 1.20 \text{ fm} = 1.20 \times 10^{-15} \text{ m}$

Step 3: Substitute the values to determine the nuclear density

$$\rho = \frac{3 \times (1.661 \times 10^{-27})}{4\pi (1.20 \times 10^{-15})^3} = 2.3 \times 10^{17} \text{ kg m}^{-3}$$

Examiner Tip

You do not need to remember the value of the Fermi radius R_0 as it is included in the data booklet in the 'fundamental constants' section.



Your notes

Rutherford Scattering Experiment

- In the Rutherford scattering experiment, alpha particles are fired at a thin gold foil
- Initially, before interacting with the foil, the particles have kinetic energy equal to

$$E_k = \frac{1}{2}mv^2$$

- Some of the alpha particles are found to come straight back from the gold foil
- This indicates that there is **electrostatic repulsion** between the alpha particles and the gold nucleus

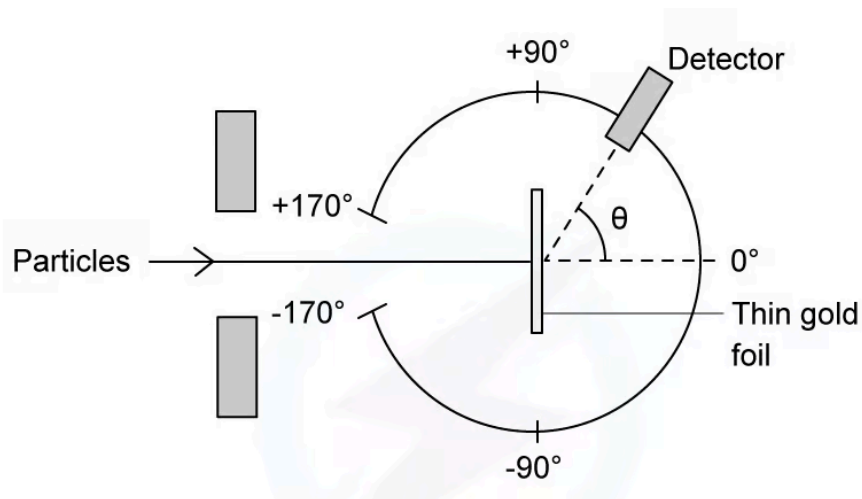

Experimental set-up of the Rutherford alpha scattering experiment

- At the point of closest approach d , the repulsive force **reduces** the speed of the alpha particles to **zero** momentarily, before any change in direction
- At this point, the **initial kinetic energy** E_k of the alpha particle is equal to the **electric potential energy**

E_p of the target nucleus:

$$E_k = E_p$$

- Where the electric potential energy is given by

$$E_p = k \frac{Qq}{d}$$

- Where:
 - Charge of an alpha particle, $Q = 2e$
 - Charge of a target nucleus, $q = Ze$
 - Z = proton (atomic) number
 - e = elementary charge (C)
 - k = Coulomb constant

- This gives an expression for the **potential energy** at the point of **repulsion**:

$$E_p = k \frac{(2e)(Ze)}{d} = k \frac{2Ze^2}{d}$$

- Which, due to the conservation of energy also gives the **initial kinetic energy** possessed by the alpha particle
- Rearranging for the distance of closest approach d

$$d = k \frac{2Ze^2}{E_p} = k \frac{2Ze^2}{E_k}$$

- This gives a value for the **radius** of the nucleus, assuming the alpha particle is fired at a high energy

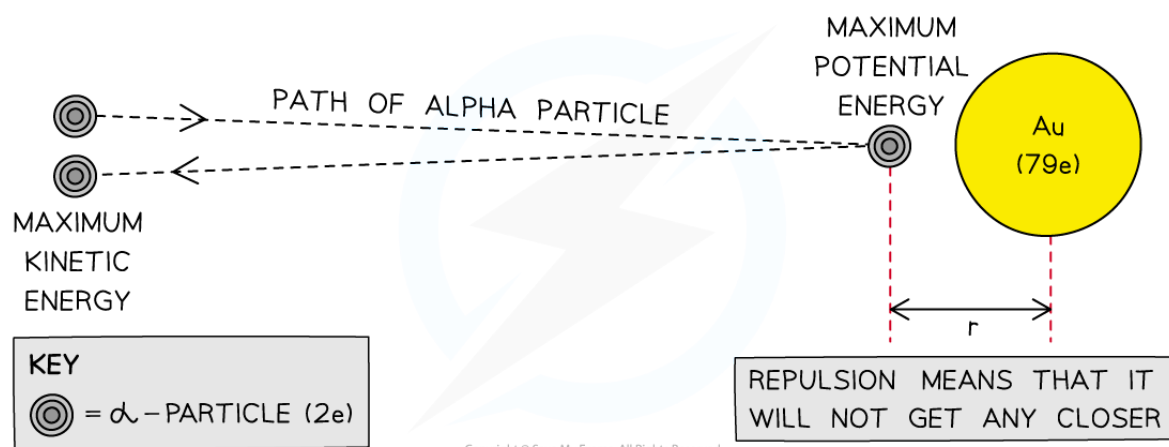

The closest approach method of determining the size of a gold nucleus

Examiner Tip

Make sure you're comfortable with the calculations involved with the alpha particle closest approach method, as this is a common exam question.

You will be expected to remember that the charge of an α is the charge of 2 protons ($2 \times$ the charge of an electron)



Your notes

Deviations from Rutherford Scattering (HL)

Deviations from Rutherford Scattering

- Rutherford's scattering experiment predicted that
 - As the scattering angle **increases**, the number of alpha particles scattered at that angle **decreases**
- This was found to be correct at low to moderately high energies
- However, at **very high energies** (>27.5 MeV) significant **deviations** from Rutherford's predictions were observed
- Instead of the number decreasing at the expected rate, the number of alpha particles being back-scattered **sharply decreases** to zero

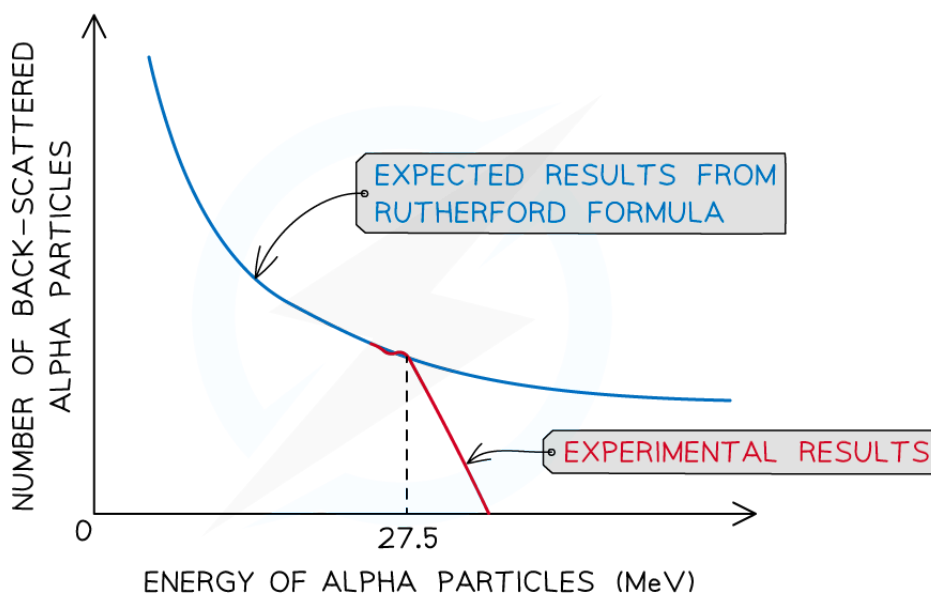

The observed back-scattering from alpha particles strongly deviates from the predicted relationship based only on electromagnetic repulsion at 27.5 MeV

- Rutherford's alpha scattering experiment originally assumed that the alpha particles **only** interact through **electrostatic repulsion**
- However, if the energy of the alpha particles exceeds 27.5 MeV, then they will be close enough to **interact** with the nucleus via the strong nuclear force
- Factoring in the interactions due to the strong nuclear force explains the scattering pattern observed in the experimental results
- Therefore, deviations from Rutherford scattering provide **evidence** for the **strong nuclear force**

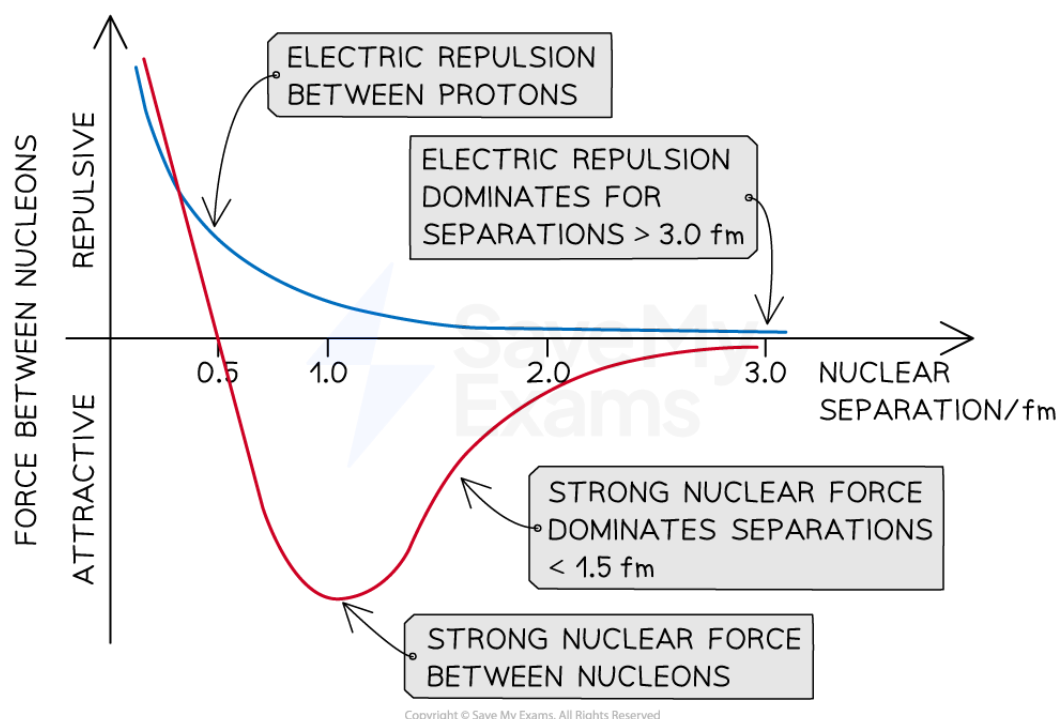

Very high-energy alpha particles can get close enough to the nucleons that the effect of the strong nuclear force becomes significant

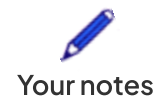

Worked example

Alpha particles undergo scattering after being fired at a thin gold ${}_{79}^{197}\text{Au}$ foil. The gold is then replaced to make a comparison.

Describe the predicted difference in the scattering pattern when the foil is replaced with aluminium ${}_{13}^{30}\text{Al}$ foil of the same thickness.

Answer:

Step 1: Compare the relative charges of the nuclei

- The force between nuclei due to the electric repulsion is

$$F = k \frac{qQ}{r^2} \Rightarrow r^2 F = kqQ$$

- Therefore, the charge of a nucleus is proportional to the square of the distance between it and an alpha particle

$$Q \propto r^2$$

- Gold has 79 protons, so $Q_{\text{gold}} = +79e$
- Aluminium has 13 protons, so $Q_{\text{aluminium}} = +13e$
- Therefore, an alpha particle will get closer to the nucleus with less charge i.e. the aluminium nucleus than the gold nucleus

Step 2: Predict the patterns and deviations from Rutherford scattering

- Deviations from Rutherford scattering occur when alpha particles get close enough for the strong nuclear force to begin to become more significant than the electric force
- At very small separations (<1.5 fm) the effect of the strong nuclear force becomes significant
- Alpha particles will be able to get closer to aluminium nuclei at lower energies than the gold nuclei
- Therefore, alpha particles will be less affected by electric repulsion and able to get close enough for interactions with the strong nuclear force
- Hence, more deviation will be seen with aluminium foil than with gold foil

Examiner Tip

Make sure you can explain when the greatest deviations from Rutherford scattering will occur i.e.

- When the alpha particles have **high energies**
- The target nuclei have a **low nucleon number**



Your notes

The Bohr Model of Hydrogen (HL)

The Bohr Model of Hydrogen

- Hydrogen is the simplest atom in existence, making it ideal for experiments investigating the nature of electron energy levels
- Line spectra produced by hydrogen atoms showed that
 - Electrons are able to jump, or **transition**, between specific energy levels producing specific energy photons
 - Different transitions can be categorised into **series**, or families, of lines
- The Lyman series converges on the **ground state** ($n = 1$) for electrons
 - The Balmer series converges on the **second** energy level ($n = 2$)
 - The Ritz-Paschen converges on the **third** energy level ($n = 3$) and so on

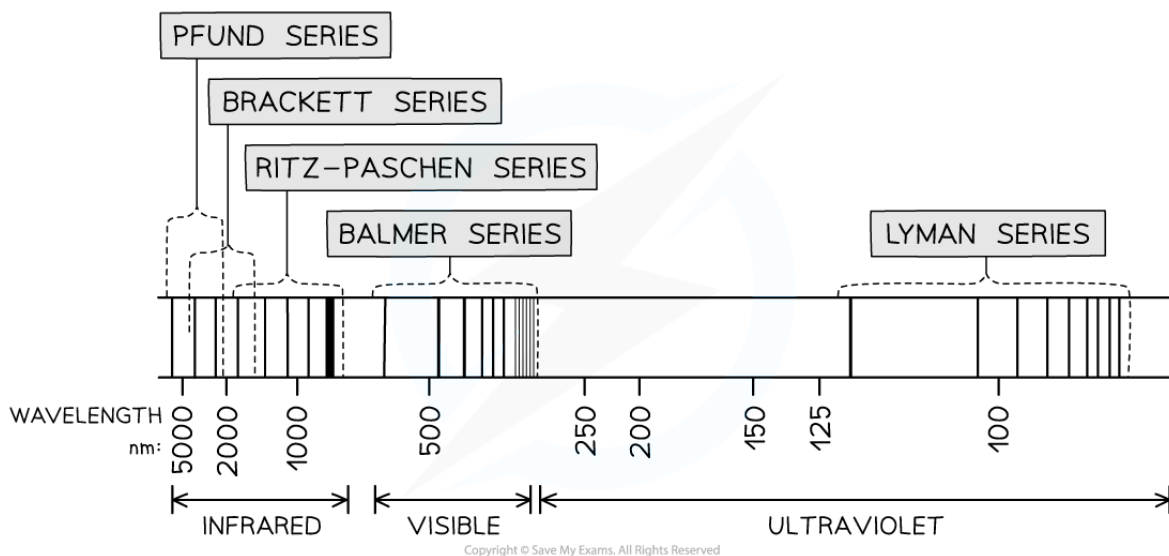

The transitions observed in hydrogen line spectra can be classed into series

- The Lyman series photons will have the **highest** energies since they have the **shortest** wavelength
 - These transitions tend to produce **ultraviolet** photons
- The Pfund series photons will have the **lowest** energies since they have the **longest** wavelength
 - These transitions tend to produce **infrared** photons

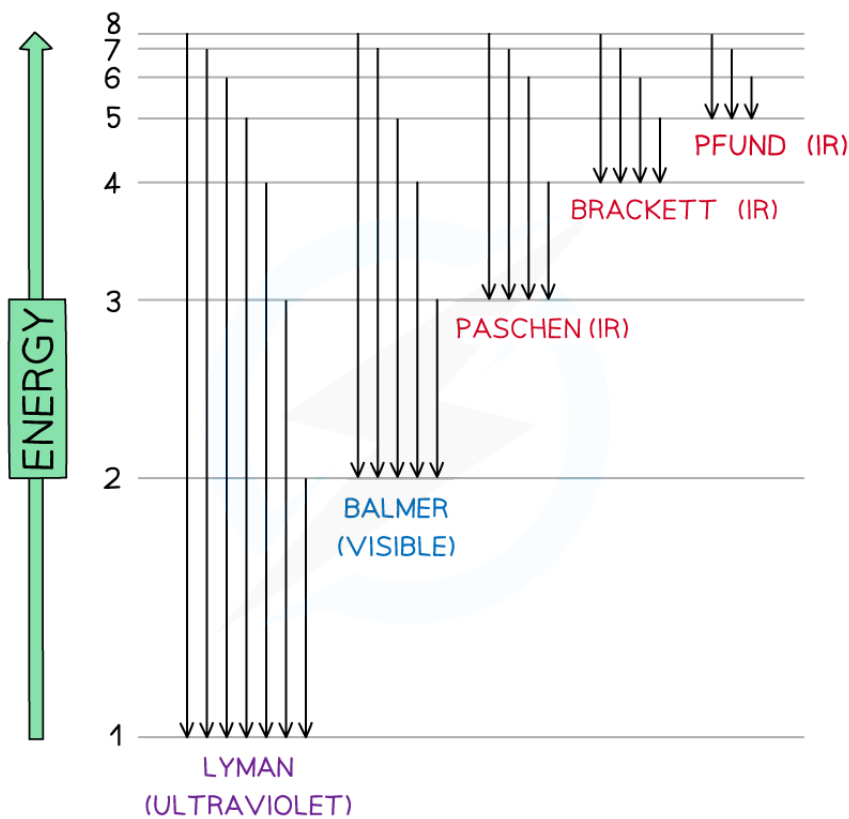

Representing the electron jumps in the hydrogen spectra

- The finding of these electron transitions helped scientists to understand how electrons work to produce photons of specific wavelength and energy
- This led to the development of the **Bohr model of hydrogen**, which states that
 - Electrons can only move in fixed orbits
 - The orbital radius of electrons is restricted to certain values
- The **discrete energy** of the transitions in the Bohr model for hydrogen are described by the equation:

$$E = -\frac{13.6}{n^2} \text{ eV}$$

- Where
 - E = photon energy (J)
 - n = an integer 1, 2, 3 etc. to describe the energy level of an atom



Your notes

Worked example

Determine the frequency of an emitted photon from a hydrogen atom when an electron makes a transition between levels $n = 4$ and $n = 2$.

Answer:

Step 1: List the known quantities

- Transition between $n = 4$ and $n = 2$
- Planck's constant, $h = 6.63 \times 10^{-34} \text{ J s}$
- Electronvolt, $eV = 1.6 \times 10^{-19} \text{ J}$

Step 2: Determine an equation for the change in energy ΔE

$$E_n = -\frac{13.6 \text{ eV}}{n^2}$$

$$\Delta E = E_4 - E_2$$

$$\Delta E = \left(-\frac{13.6 \text{ eV}}{4^2}\right) - \left(-\frac{13.6 \text{ eV}}{2^2}\right)$$

Step 3: Calculate the change in energy, in eV, for the photon using the given equation

$$\Delta E = -13.6 \left(\frac{1}{4^2} - \frac{1}{2^2}\right) = 2.55 \text{ eV}$$

Step 4: Rearrange the photon energy equation for frequency f

$$E = hf \quad \Rightarrow \quad f = \frac{E}{h}$$

Step 5: Substitute the known values into the equation for frequency

$$f = \frac{2.55 \times (1.6 \times 10^{-19})}{6.63 \times 10^{-34}} = 6.15 \times 10^{14} \text{ Hz}$$



Your notes

Quantisation of Angular Momentum

- Angular momentum is a property of any spinning or rotating body, very similar to linear momentum
 - In linear motion, momentum is the product of mass and velocity
 - In rotational motion, the momentum is the product of moment of inertia and angular speed
- Angular momentum is a vector, which means:
 - The **magnitude** is equal to the momentum of the particle times its radial distance from the centre of its circular orbit
 - The **direction** of the angular momentum vector is normal to the plane of its orbit with the direction being given by the corkscrew rule

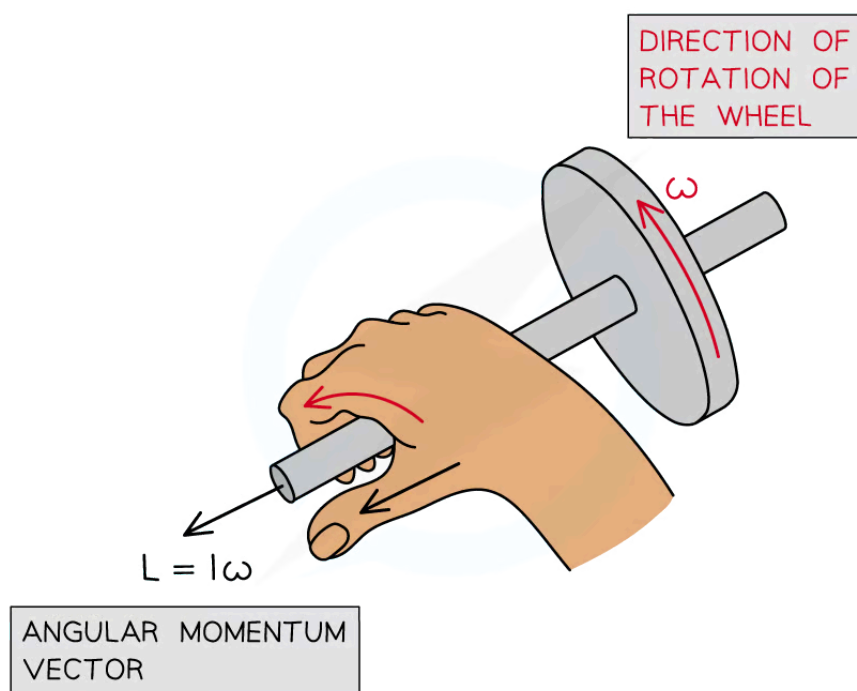

Copyright © Save My Exams. All Rights Reserved

Angular momentum acts at right angles to the direction of rotation

- Niels Bohr proposed that the angular momentum L of an electron in an energy level is quantised in integer multiples of Planck's constant over 2π :

$$L = n \frac{h}{2\pi}$$

- Where:
 - n = an integer ($n = 1, 2, 3, \dots$)
 - h = Planck's constant
- Hence the angular momentum for an electron in a circular orbit is **constant**
- De Broglie proposed that an electron with momentum $p = mv$ has a wavelength λ given by

$$\lambda = \frac{h}{p}$$

- For an electron moving in a straight line, the matter wave takes a familiar wave shape consisting of peaks and troughs
 - Although the electron itself isn't oscillating up and down, only the matter wave is

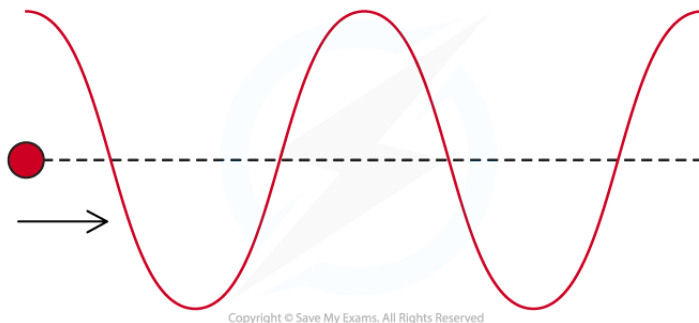

de Broglie matter wave for an electron moving in a straight line at constant speed

- For the same electron moving in a circle, the matter wave still has a sinusoidal shape but is wrapped into a circle

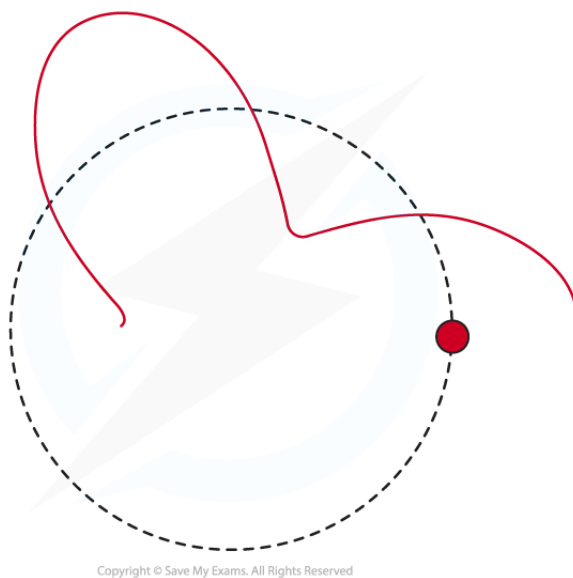

de Broglie matter wave for an electron moving in a circular orbit at constant speed

- As the electron continues to orbit in a circle two possibilities may occur:
 - On completing one oscillation, the waves overlap in phase**
 - The waves will continue in phase over many orbits giving rise to constructive interference and a standing wave



Your notes

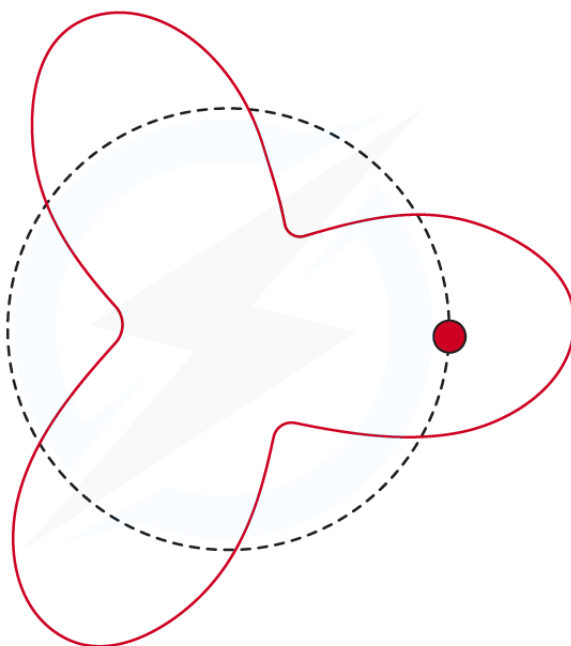

Copyright © Save My Exams. All Rights Reserved

de Broglie matter wave where $n = 3$. Here the circumference of the circular orbit is 3λ

2. On completing one oscillation, the waves overlap but they are not in phase

- In other words, peak overlaps with peak, trough with trough
- This means that where the waves overlap, destructive interference occurs and as a result, no such electron orbit is allowed



Your notes

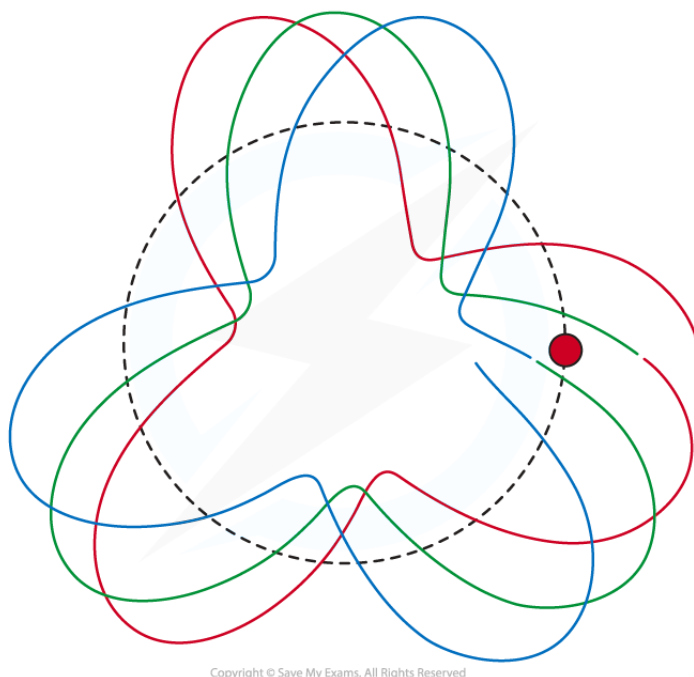

Copyright © Save My Exams. All Rights Reserved

de Broglie matter wave where 3λ is less than the orbit's circumference

- Hence, the circumference of the orbit ($2\pi r$) must equal an integer number of wavelengths ($n\lambda$) for a standing wave to form:

$$n\lambda = 2\pi r$$

- Using the de Broglie relation:

$$\lambda = \frac{h}{p}$$

$$n\left(\frac{h}{p}\right) = 2\pi r$$

- Since momentum is equal to $p = mv$:

$$n\left(\frac{h}{mv}\right) = 2\pi r$$

- Rearranging for angular momentum ($L = mvr$):

$$\frac{nh}{2\pi} = mvr$$

- This is known as the **Bohr Condition**



Your notes

- Where:
 - n = integer number of energy level
 - h = Planck's constant (J s)
 - m = mass of an electron (kg)
 - v = velocity of electron (m s^{-1})
 - r = radius of orbit (m)

Worked example

Determine the velocity of the electron in the first Bohr orbit of the hydrogen atom.

You may use the following values:

- Mass of an electron = 9.1×10^{-31} kg
- Radius of the orbit = 0.529×10^{-10} m
- Planck's constant = 6.63×10^{-34} kg m² s⁻¹

Answer:

Step 1: List the known quantities

- First orbital level, $n = 1$
- Mass of an electron, $m = 9.1 \times 10^{-31}$ kg
- Radius of the orbit, $r = 0.529 \times 10^{-10}$ m
- Planck's constant, $h = 6.63 \times 10^{-34}$ kg m² s⁻¹

Step 2: Write the Bohr Condition equation and rearrange for velocity, v

$$\frac{nh}{2\pi} = mvr \quad \Rightarrow \quad v = \frac{nh}{2\pi mr}$$

Step 3: Substitute the values in and calculate the velocity v

$$v = \frac{1 \times (6.63 \times 10^{-34})}{2\pi \times (9.1 \times 10^{-31})(0.529 \times 10^{-10})}$$

Step 4: Write the final answer

$$\text{Velocity of an electron } (n = 1): v = 2.2 \times 10^6 \text{ m s}^{-1}$$