

# HL IB Physics



Your notes

## Rigid Body Mechanics

### Contents

- \* Torque & Couples (HL)
- \* Rotational Equilibrium (HL)
- \* Angular Displacement, Velocity & Acceleration (HL)
- \* Angular Acceleration Formula (HL)
- \* Moment of Inertia (HL)
- \* Newton's Second Law for Rotation (HL)
- \* Angular Momentum (HL)
- \* Angular Impulse (HL)
- \* Rotational Kinetic Energy (HL)



Your notes

## Torque & Couples (HL)

### Torque & Couples

#### Moment of a Force

- A moment is the **turning effect** of a force around a particular point
- Moments occur when forces cause objects to **rotate** about some pivot
- The moment of a force is given by  

$$\text{Moment (Nm)} = \text{Force (N)} \times \text{perpendicular distance from the pivot (m)}$$

- The SI unit for the moment is newton metres (**N m**)

#### Moments of perpendicular & non-perpendicular forces

SCENARIO 1:  
PERPENDICULAR  
FORCE

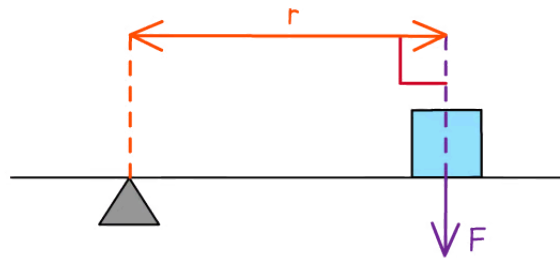

$$\text{MOMENT} = F \times r$$

ALTHOUGH  $r$  IS THE DISTANCE FROM THE PIVOT TO THE FORCE  $F$ , IT IS NOT THE PERPENDICULAR DISTANCE. THEREFORE WE MUST TAKE THE COMPONENT OF THE DISTANCE WHICH IS PERPENDICULAR TO  $F$ .

SCENARIO 2:  
NON-PERPENDICULAR  
FORCE

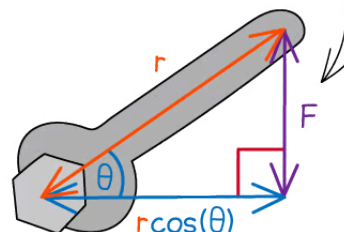

$$\text{MOMENT} = F \times r \cos(\theta)$$

Copyright © Save My Exams. All Rights Reserved

*The force might not always be perpendicular to the distance. In this case, use trigonometry to resolve in the perpendicular direction*



Your notes

## Couples

- A couple is a **pair** of equal and opposite coplanar forces that act to produce **rotation** only
- A couple consists of a pair of forces that are:
  - Equal in magnitude
  - Opposite in direction
  - Perpendicular to the distance between them

### Force couple diagram

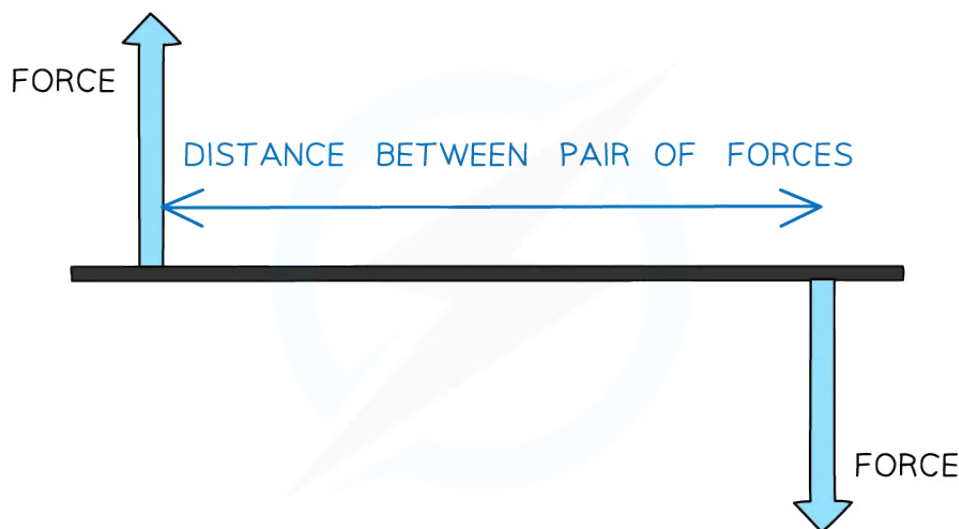

Copyright © Save My Exams. All Rights Reserved

***A couple must consist of two equal and opposite forces separated by a perpendicular distance***

- Unlike moments of a single force, the moment of a couple doesn't depend on a pivot
- The moment of a couple is equal to:
 

Moment (**N m**) = Force (**N**) × Perpendicular distance between the lines of action of the forces (**m**)
- A couple does not produce a net linear force
  - However, it does produce a turning effect called a **torque**

## Torque

- The change in rotational motion due to a turning force is called **torque**
- The torque of a force  $F$  about an axis is given by

$$\tau = Fr \sin \theta$$

### Torque of a non-perpendicular force



Your notes

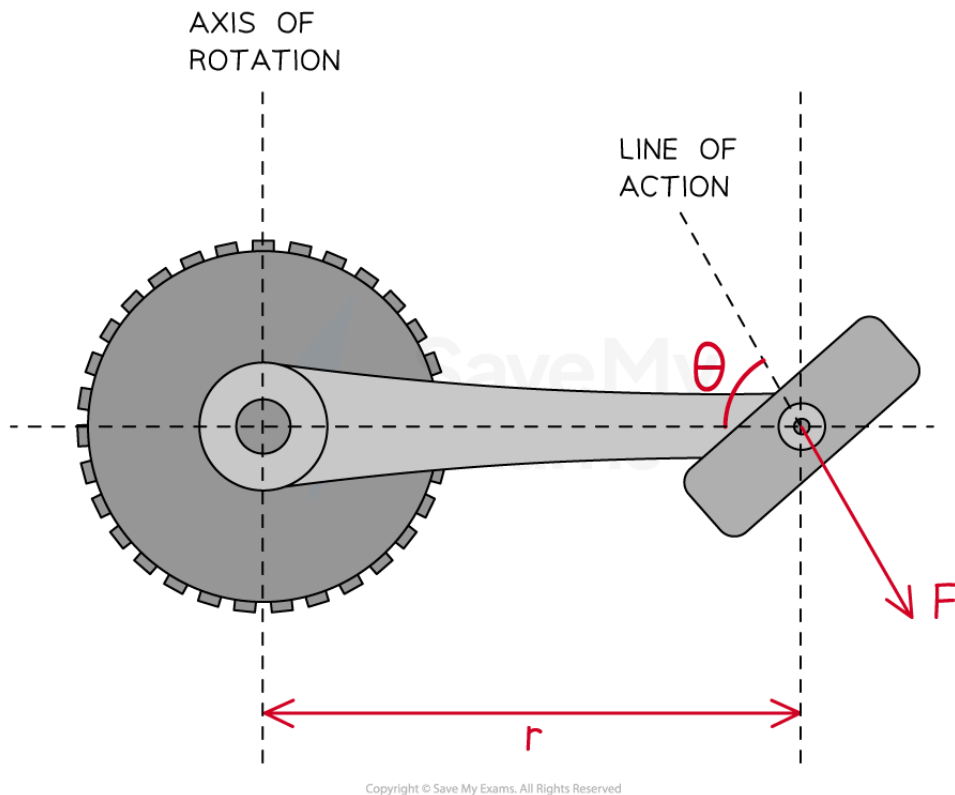

**The torque applied by a cyclist on a bicycle pedal can be determined using the magnitude of the applied force and the perpendicular component of the distance between the line of action of the force and the axis of rotation**

- For scenarios where the forces are perpendicular ( $\theta = 90^\circ$ ) to one another, the equation simplifies to

$$\tau = Fr$$

- Where:

- $\tau$  = torque (N m)
- $F$  = applied force (N)
- $r$  = perpendicular distance between the axis of rotation and the line of action of the force (m)
- $\theta$  = angle between the force and the axis of rotation ( $^\circ$ )

### Torque of a couple on a steering wheel



Your notes

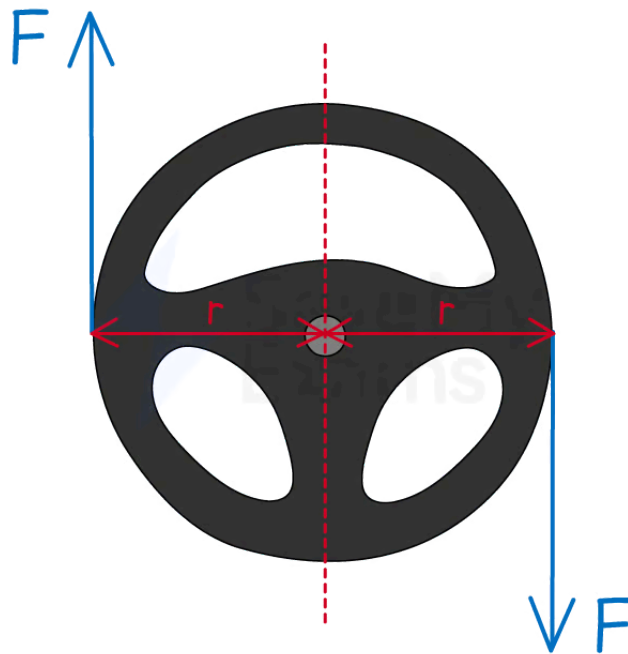

Copyright © Save My Exams. All Rights Reserved

**The steering wheel is in rotational equilibrium since the resultant force and resultant torque are zero. This means it does not have linear or angular acceleration.**

- When applied to a couple, torque can be described as  
**The sum of the moments produced by each of the forces in the couple**

- For example, the torque provided by a couple on a steering wheel of radius  $r$  is  
$$\tau = (F \times r \sin \theta) + (F \times r \sin \theta) = 2Fr \sin \theta$$

Since  $\theta = 90^\circ$ , then  $\tau = 2Fr$

- Therefore, the torque of a couple is equal to **double** the magnitude of the torque of the individual forces
- The forces are equal and act in opposite directions
  - Therefore, couples produce a resultant force of **zero**
- Due to Newton's Second law ( $\mathbf{F} = m\mathbf{a}$ ), the steering wheel does **not** accelerate
  - In other words, when the force is applied, the steering wheel rotates with a **constant** angular speed but remains in the same location

**The effect of angle on torque**



Your notes

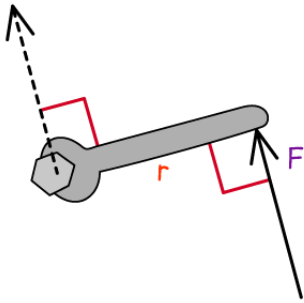

MAXIMUM  
TORQUE  
WHEN  $\theta = 90^\circ$

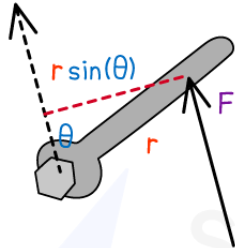

REDUCED  $\theta$   
→ REDUCED  
TORQUE

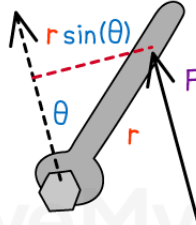

SAME FORCE  
LESS TORQUE

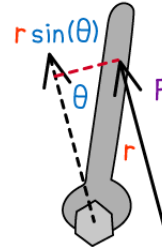

TORQUE  
APPROACHES  
ZERO AS THE  
ANGLE BETWEEN  
THE FORCE AND  
THE HANDLE  
APPROACHES  
ZERO

Copyright © Save My Exams. All Rights Reserved

**The force produces a maximum torque when applied perpendicular to the wrench. The same force is less effective when applied at non-perpendicular angles**



Your notes

### Worked example

Which pair of forces act as a couple on the circular object?

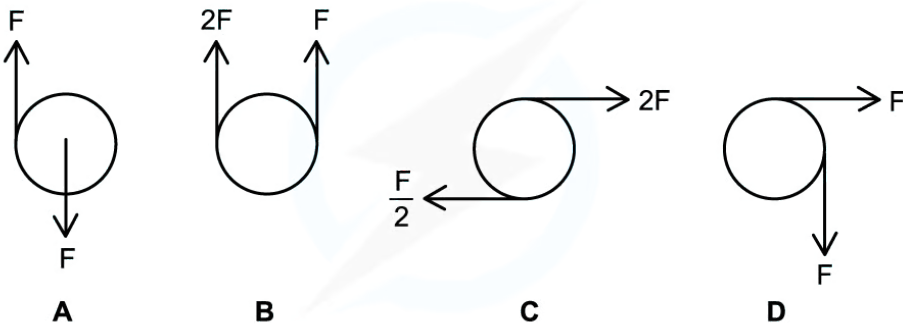

Copyright © Save My Exams. All Rights Reserved

**Answer: A**

- In diagram **A**, the forces are:
  - Equal in size
  - In opposite directions
  - Perpendicular to the distance between them
- **B** is incorrect as the forces are in the same direction
- **C** is incorrect as the forces are different in size
- **D** is incorrect as the distance between the forces is not perpendicular



Your notes

**Worked example**

A ruler of length 0.3 m is pivoted at its centre.

Two equal and opposite forces of magnitude 4 N are applied to the ends of the ruler, creating a couple as shown in the diagram.

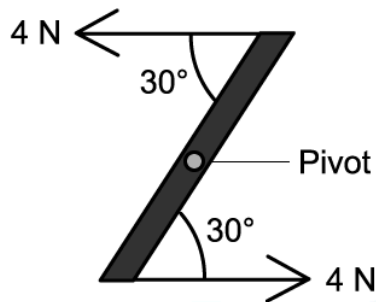

Determine the magnitude of the torque of the couple on the ruler.

**Answer:**

STEP 1 **TORQUE = FORCE × PERPENDICULAR DISTANCE**

STEP 2 FIND THE COMPONENT OF THE FORCE THAT IS PERPENDICULAR TO THE DISTANCE

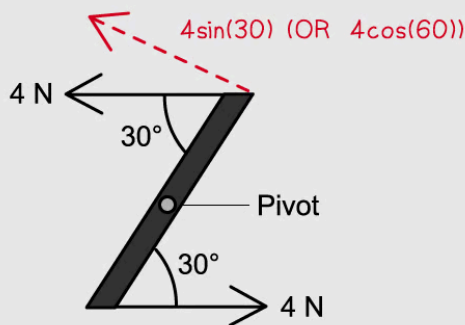

STEP 3 SUBSTITUTE VALUES INTO THE EQUATION

$$\text{TORQUE} = 4 \sin(30) \text{ N} \times 0.3 = 0.6 \text{ Nm}$$





Your notes



Your notes

 **Worked example**

The forces acting on a bicycle pedal at different positions during a ride are shown in the diagram below.

The distance from the pedal to the axis of rotation is 24 cm.

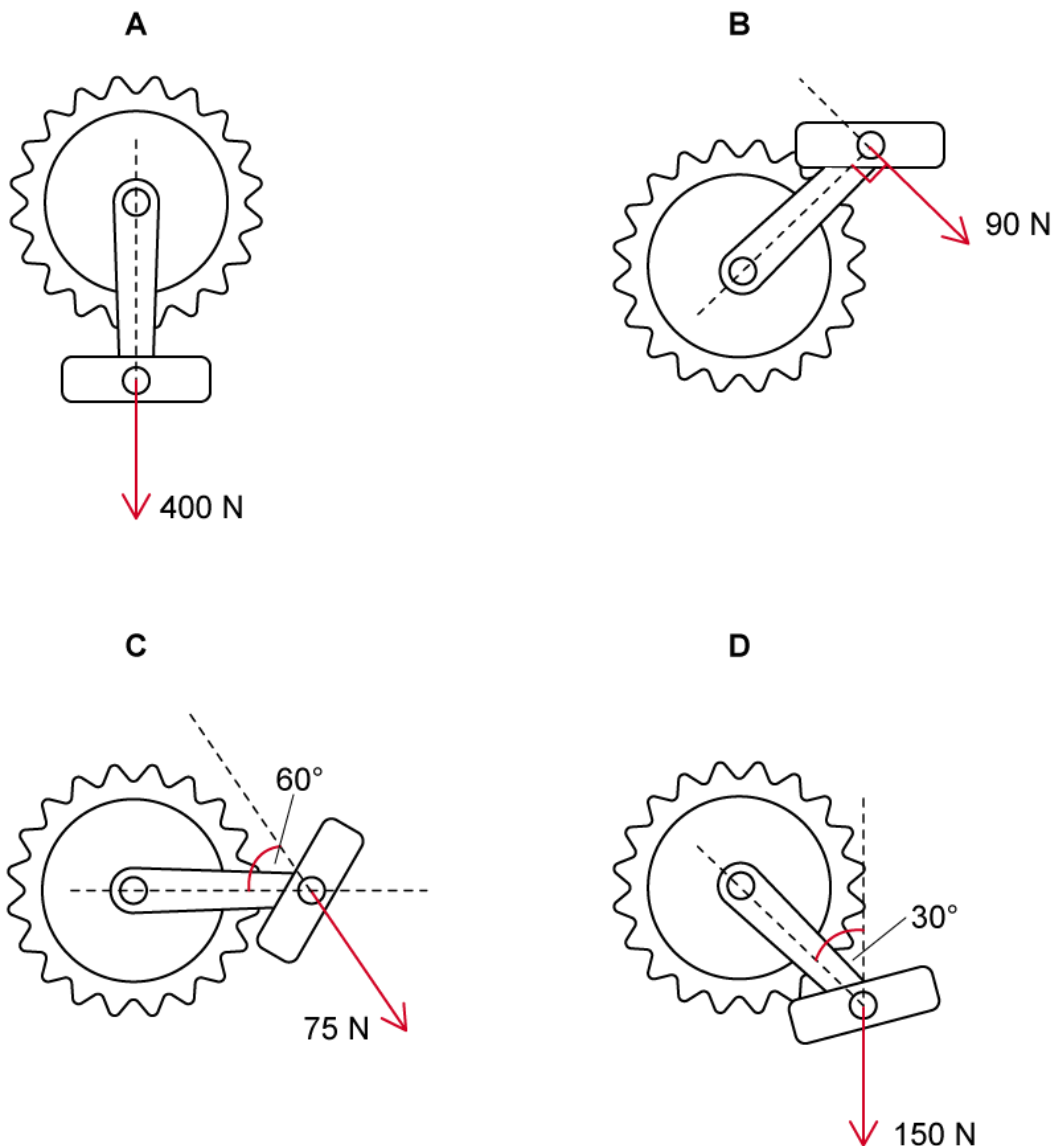

At which position is the magnitude of the torque the greatest?

**Answer: B**

- In position **A**: When  $\theta = 180^\circ$ ,  $\sin \theta = 0$ , so  $\tau = 0$  i.e. the force exerts no torque on the pedal. When the pedal is at the bottom, no amount of pushing down will produce any torque on the pedal.
- In position **B**: When the angle  $\theta$  is  $90^\circ$  and the force  $F$  is 90 N, the torque  $\tau = 0.24 \times 90 \times \sin 90^\circ =$   
**21.6 N m**
- In position **C**: When the angle  $\theta$  is  $60^\circ$  and the force  $F$  is 75 N, the torque  $\tau = 0.24 \times 75 \times \sin 60^\circ =$   
**15.6 N m**
- In position **D**: When the angle  $\theta$  is  $30^\circ$  and the force  $F$  is 150 N, the torque  $\tau = 0.24 \times 150 \times \sin 30^\circ =$   
**18.0 N m**



Your notes



Your notes

### Examiner Tip

The terminology in this section can get confusing. For example, a moment is not a 'turning force' - the turning force is only part of the moment, the moment is the **effect** that the turning force has on the system when applied at a **distance** from a turning point, or pivot.

Also, torque is another term for 'moment', but in mechanics, torque can be used to describe a couple as a specific case of a moment.

Ultimately, when you carry out calculations, make sure you can identify

- The magnitude of the **applied force**
- The **perpendicular distance** between the force and the turning point (along the line of action)

Make sure you understand that the forces that make up a **couple** cannot share the same line of action (the line through the point at which the force is applied). An example of this is shown in the diagram below:

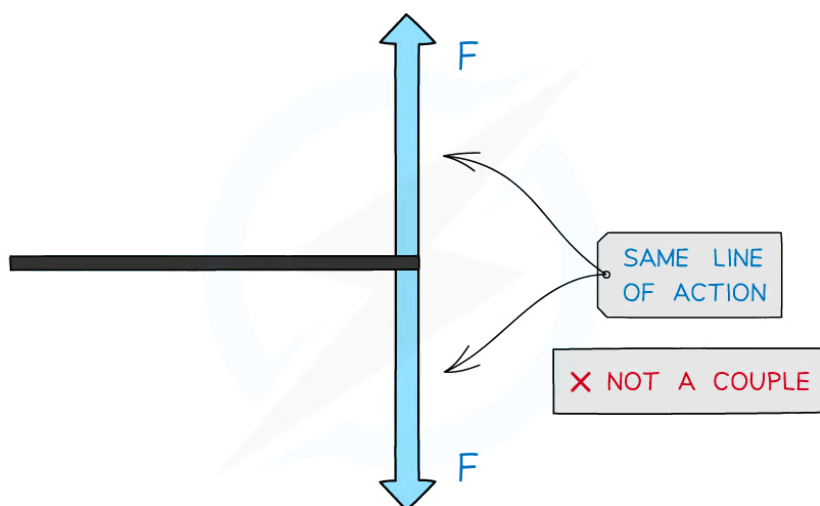

Copyright © Save My Exams. All Rights Reserved



Your notes

## Rotational Equilibrium (HL)

### Rotational Equilibrium

- A system is said to be in **rotational equilibrium** when
  - There is **no** resultant force acting
  - There is **no** resultant torque acting
- An object in rotational equilibrium will therefore remain **at rest**, or rotate with a **constant** angular velocity
  - This is analogous to [Newton's First Law](#) for translational equilibrium
- This means a body is in rotational equilibrium if
  - The sum of the clockwise moments is equal to the sum of the anticlockwise moments**
- This is also known as the principle of moments and can be applied to a range of scenarios, such as a balanced beam
  - A beam is an example of a rigid, extended body

#### A balanced beam in rotational equilibrium

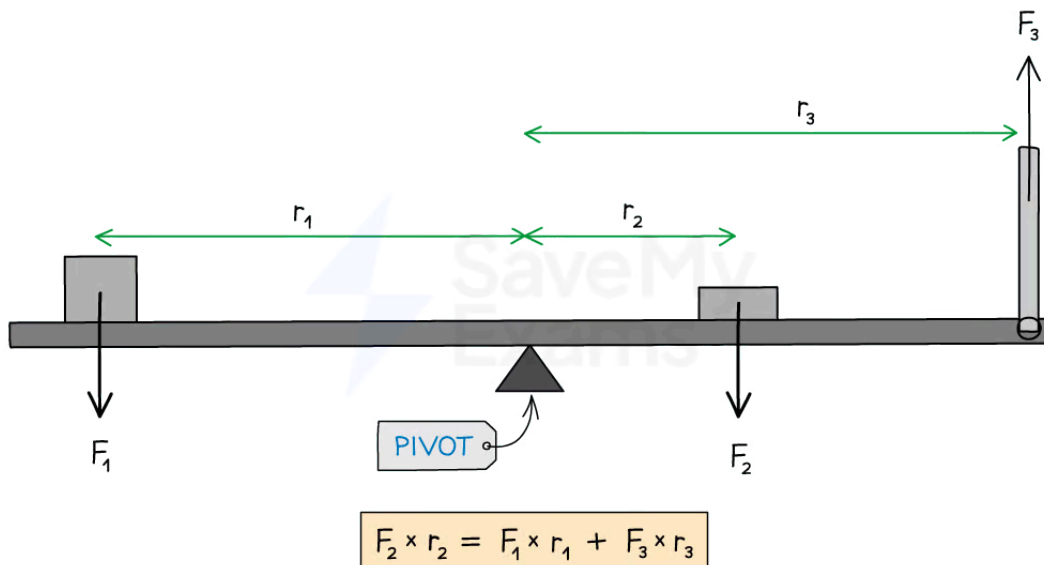

Copyright © Save My Exams. All Rights Reserved

**When the resultant force and resultant torque are both zero, the beam will be in rotational equilibrium**



Your notes

### Worked example

Four beams of the same length each have three forces acting on them.

Which of the beams is in rotational equilibrium?

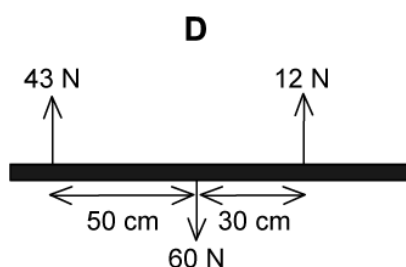
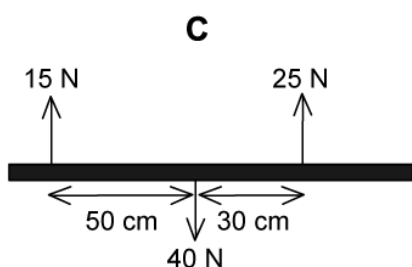
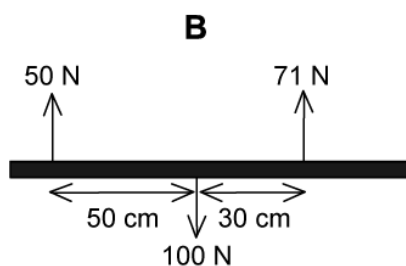
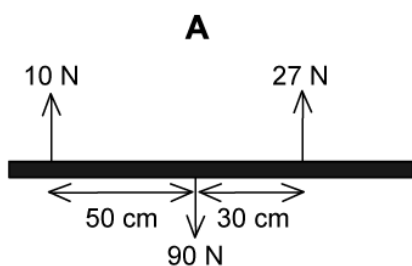

**Answer: C**

- A beam is in rotational equilibrium when there is **zero** resultant force and **zero** resultant torque acting on it
- In rotational equilibrium:

$$\text{Total clockwise torque} = \text{Total anticlockwise torque}$$

- Consider beam **C**, taking torques from the centre of the beam (where its weight acts):

$$\text{Torque, } \tau = Fr \text{ (as } \sin 90^\circ = 1)$$

$$\text{Total clockwise torque} = 15 \times 50 = 750 \text{ N cm}$$

$$\text{Total anticlockwise torque} = 25 \times 30 = 750 \text{ N cm}$$

- The total clockwise torque (750 N cm) = total anticlockwise torque (750 N cm), therefore, beam **C** is in rotational equilibrium

The other beams are **not** in rotational equilibrium because...

- Beam **A** has a resultant torque of 310 N cm anticlockwise
- Beam **B** has a resultant torque of 370 N cm clockwise
- Beam **D** has a resultant torque of 1790 N cm clockwise

 **Examiner Tip**

When considering an object in rotational equilibrium, choosing certain points can simplify calculations of resultant torque. Remember you can choose **any** point, not just the axis of rotation.

To simplify your calculation, choose a point where the torque of (most of) the forces are unknown, or when you need to determine where the resultant torque is **zero**. To do this, choose a point through which the lines of action of the forces pass



Your notes



Your notes

## Unbalanced Torque

- In the same way that a resultant force produces linear acceleration, a **resultant torque** produces **angular acceleration**
- The **direction** of the angular acceleration depends on the direction of the net resultant torque

### Beam with an unbalanced torque

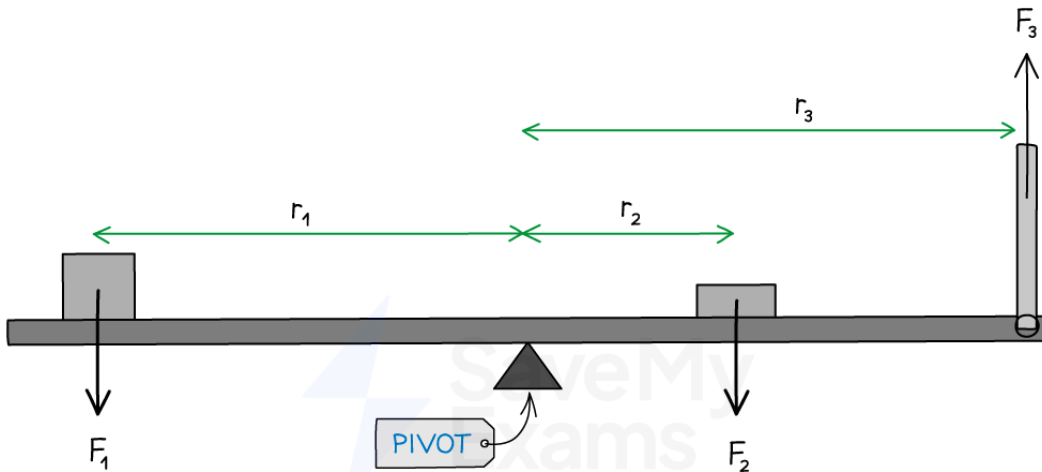

$$F_2 \times r_2 > F_1 \times r_1 + F_3 \times r_3$$

$$F_2 \times r_2 < F_1 \times r_1 + F_3 \times r_3$$

NET RESULTANT TORQUE  
 $= F_2 r_2 - (F_1 r_1 + F_3 r_3)$

DIRECTION: 

NET RESULTANT TORQUE  
 $= (F_1 r_1 + F_3 r_3) - F_2 r_2$

DIRECTION: 

Copyright © Save My Exams. All Rights Reserved

*If there is a net resultant torque in the clockwise or anti-clockwise direction, the beam will also have an angular acceleration in that direction*





Your notes

### Worked example

A uniform plank of mass 30 kg and length 10 m is supported at its left end and at a point 1.5 m from the centre.

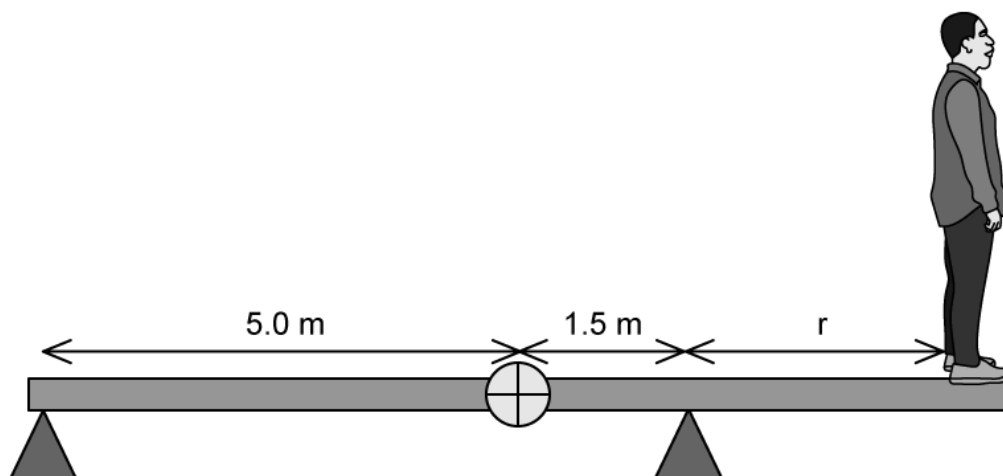

Calculate the maximum distance  $r$  to which a boy of mass 50 kg can walk without tipping the rod over.

**Answer:**

#### Step 1: Analyse the scenario and identify the forces

- Let the forces at each support be  $F_L$  (reaction force from the left support) and  $F_R$  (reaction force from the right support)
  - These are vertically upwards
- Just before the plank tips over, the system is in rotational equilibrium
- When the plank begins to tip over, the left support force  $F_L$  will become zero since the rod will no longer touch the support

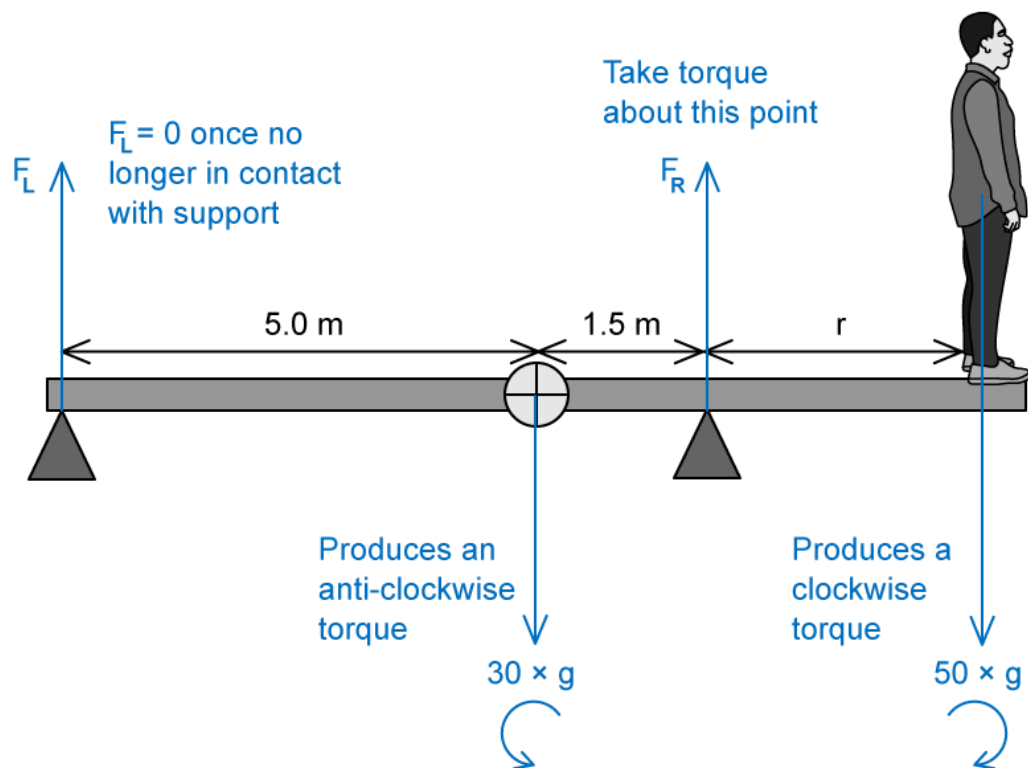

**Step 2: Take torques about the right support**

- Torque =  $Fr \sin \theta$  ( $\theta = 90^\circ$  for all)
- Clockwise torque =  $50 \times g \times r$
- Anti-clockwise torque =  $30 \times g \times 1.5$

**Step 3: Equate the clockwise and anti-clockwise torques**

$$30 \times g \times 1.5 = 50 \times g \times r$$

$$r = \frac{30\cancel{g} \times 1.5}{50\cancel{g}} = \frac{30 \times 1.5}{50}$$

$$r = 0.90 \text{ m}$$

- Therefore, the plank will begin to tip once the boy is 0.90 m from the right support



Your notes

### Worked example

The diagram shows three forces acting on a wheel.

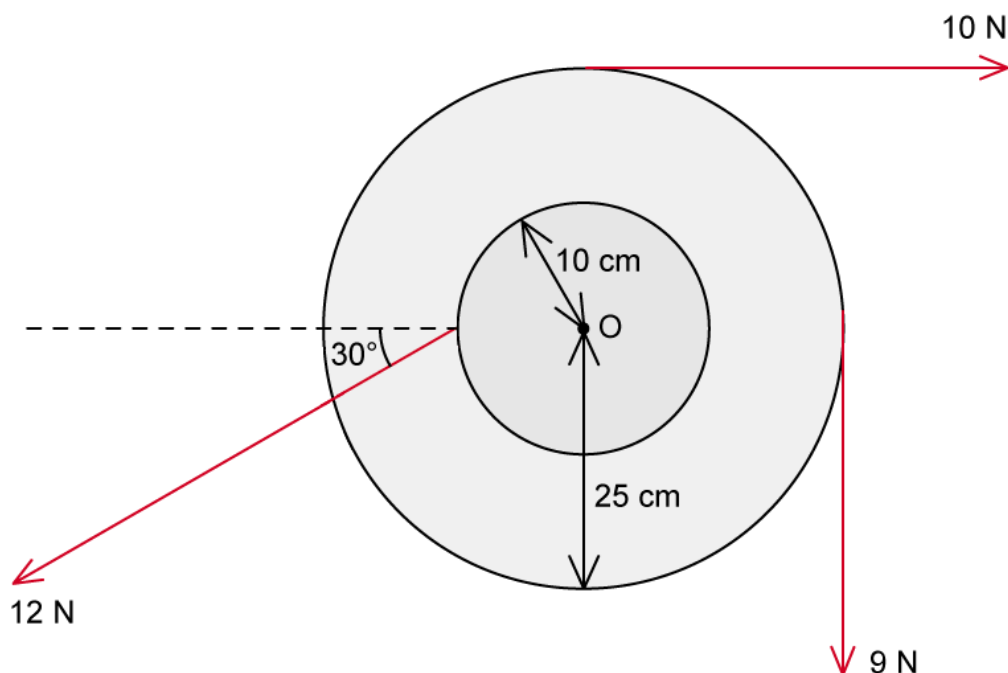

Determine the net resultant torque about the axis of rotation O. State whether the angular acceleration that is produced is clockwise or anticlockwise.

**Answer:**

**Step 1: Recall the equation for torque**

$$\tau = Fr \sin \theta$$

**Step 2: Find the sum of the torques in the clockwise direction**

Torque of the 10 N force:  $\tau = 10 \times 0.25 \times \sin 90^\circ = 2.5 \text{ N m}$

Torque of the 9 N force:  $\tau = 9 \times 0.25 \times \sin 90^\circ = 2.25 \text{ N m}$

Total clockwise torque =  $2.5 + 2.25 = 4.75 \text{ N m}$

**Step 3: Calculate the torque in the anti-clockwise direction**



Your notes

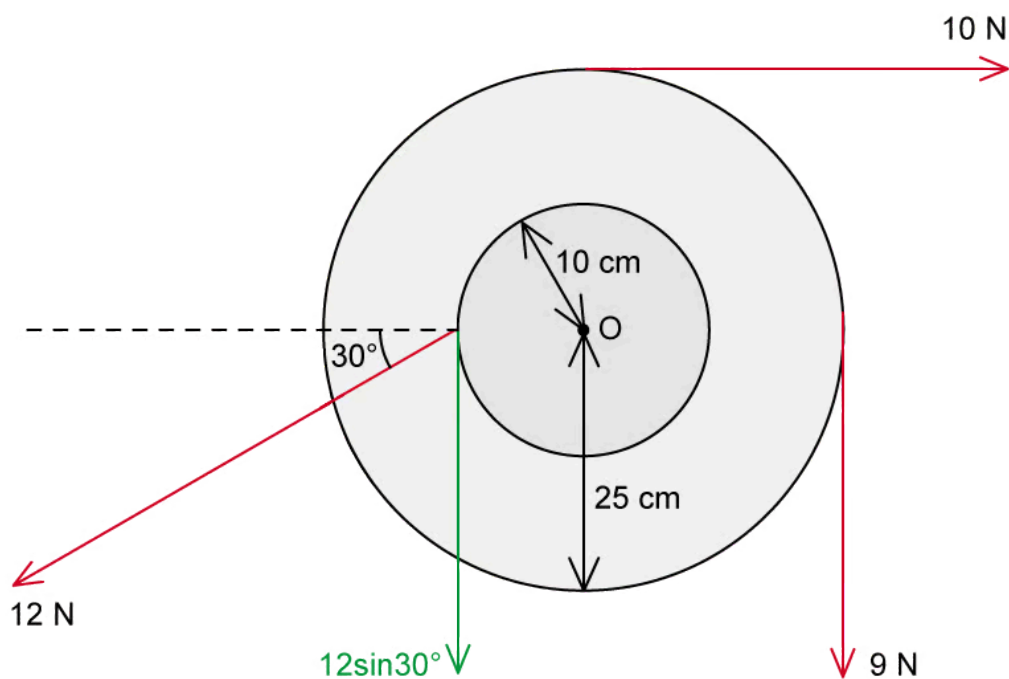

Torque of the 12 N force:  $\tau = 12 \times 0.1 \times \sin 30^\circ = 0.6 \text{ N m}$

Total anti-clockwise torque = 0.6 N m

**Step 4: Determine the net resultant torque**

- Resultant torque = sum of clockwise torques – sum of anti-clockwise torques
- Resultant torque:  $\sum \tau = 4.75 - 0.6 = 4.15 \text{ N m}$ , clockwise
- Direction of angular acceleration: **clockwise**



Your notes

 **Examiner Tip**

You should know that torque is a vector quantity, however, at this level, you will only need to consider whether it produces clockwise or anti-clockwise motion

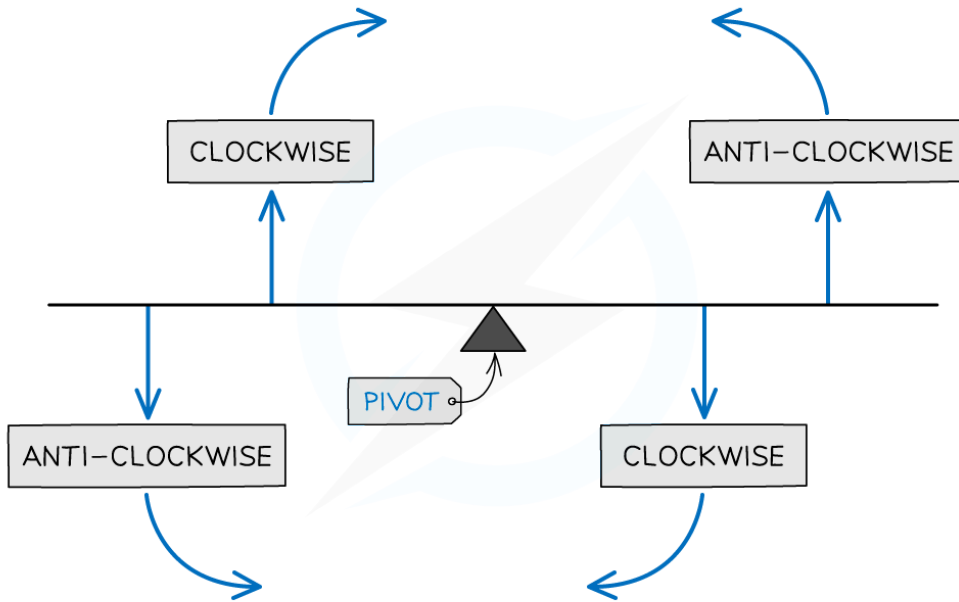

Copyright © Save My Exams. All Rights Reserved



Your notes

## Angular Displacement, Velocity & Acceleration (HL)

### Angular Displacement, Velocity & Acceleration

- A rigid rotating body can be described using the following properties:
  - Angular displacement
  - Angular velocity
  - Angular acceleration
- These properties can be inferred from the properties of objects moving in a straight line combined with the geometry of circles and arcs

### Angular Displacement

- Angular displacement is defined as:
 

**The change in angle through which a rigid body has rotated relative to a fixed point**
- Angular displacement is measured in radians

### Angular displacement to linear displacement

- The linear displacement  $s$  at any point along a segment that is in rotation can be calculated using:

$$s = r\theta$$

- Where:
  - $\theta$  = angular displacement, or change in angle (radians)
  - $s$  = length of the arc, or the linear distance travelled along a circular path (m)
  - $r$  = radius of a circular path, or distance from the axis of rotation (m)

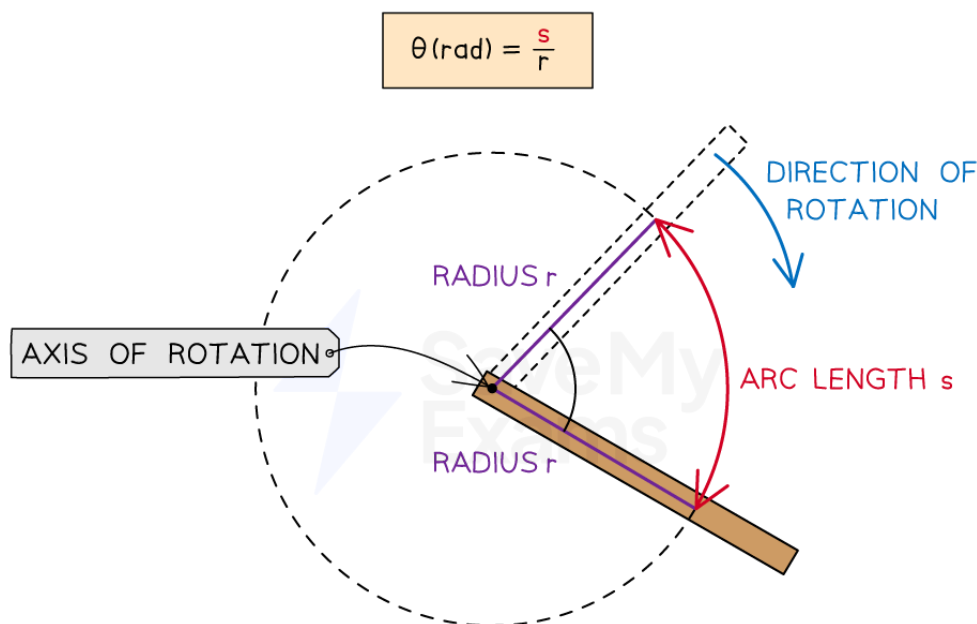

Copyright © Save My Exams. All Rights Reserved

*An angle in radians, subtended at the centre of a circle, is the arc length divided by the radius of the circle*



Your notes

## Angular Velocity

- The angular velocity  $\omega$  of a rigid rotating body is defined as:  
**The rate of change in angular displacement with respect to time**

- Angular velocity is measured in  $\text{rad s}^{-1}$
- This can be expressed as an equation:

$$\omega = \frac{\Delta \theta}{\Delta t}$$

- Where:
  - $\omega$  = angular velocity ( $\text{rad s}^{-1}$ )
  - $\Delta \theta$  = angular displacement (rad)
  - $\Delta t$  = change in time (s)

## Angular velocity to linear velocity

- The linear speed  $v$  is related to the angular speed  $\omega$  by the equation:

$$v = r\omega$$

- Where:
  - $v$  = linear speed ( $\text{m s}^{-1}$ )
  - $r$  = distance from the axis of rotation (m)
- Taking the angular displacement of a complete cycle as  $2\pi$ , angular velocity  $\omega$  can also be expressed as:

$$\omega = \frac{v}{r} = 2\pi f = \frac{2\pi}{T}$$

- Rearranging gives the expression for linear speed:

$$v = 2\pi fr = \frac{2\pi r}{T}$$

- Where:
  - $f$  = frequency of the rotation (Hz)
  - $T$  = time period of the rotation (s)

## Angular Acceleration

- Angular acceleration  $\alpha$  is defined as  
**The rate of change of angular velocity with time**
- Angular acceleration is measured in  $\text{rad s}^{-2}$
- This can be expressed as an equation:



Your notes

$$\alpha = \frac{\Delta \omega}{\Delta t}$$

- Where:
  - $\alpha$  = angular acceleration ( $\text{rad s}^{-2}$ )
  - $\Delta \omega$  = change in angular velocity, or  $\Delta \omega = \omega_f - \omega_i$  ( $\text{rad s}^{-1}$ )
  - $\Delta t$  = change in time (s)

### Angular acceleration to linear acceleration

- Using the definition of angular velocity  $\omega$  with the equation for angular acceleration  $\alpha$  gives:

$$\Delta \omega = \frac{\Delta v}{r}$$

$$\alpha = \frac{\Delta \omega}{\Delta t} = \frac{\Delta v}{r \Delta t} = \frac{a}{r}$$

- Rearranging gives the expression for linear acceleration:

$$a = r\alpha$$

- Where:
  - $a$  = linear acceleration ( $\text{m s}^{-2}$ )
  - $r$  = distance from the axis of rotation (m)
  - $\Delta v$  = change in linear velocity, or  $\Delta v = v - u$  ( $\text{m s}^{-1}$ )

### Graphs of Rotational Motion

- Graphs of rotational motion can be interpreted in the same way as linear [motion graphs](#)





Your notes

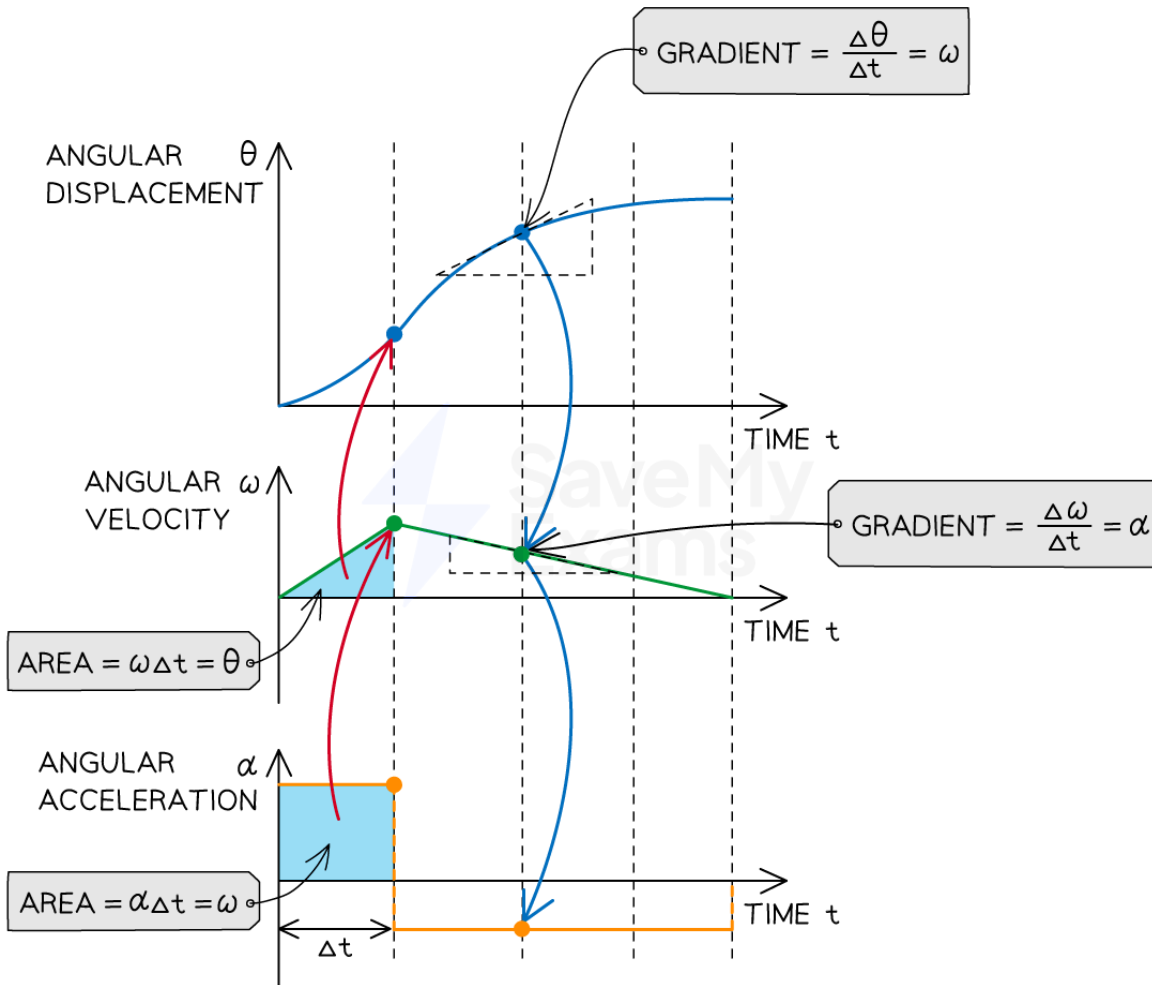

**Graphs of angular displacement, angular velocity and angular acceleration**

- Angular displacement is equal to...
  - The **area under** the angular velocity-time graph
- Angular velocity is equal to...
  - The **gradient** of the angular displacement-time graph
  - The **area under** the angular acceleration-time graph
- Angular acceleration is equal to...
  - The **gradient** of the angular velocity-time graph

**Summary of linear and angular variables**

Variable	Linear	Angular
----------	--------	---------

displacement	$s = r\theta$	$\theta = \frac{s}{r}$
velocity	$v = r\omega$	$\omega = \frac{v}{r}$
acceleration	$a = r\alpha$	$\alpha = \frac{a}{r}$



Your notes

 **Examiner Tip**

While there are many similarities between the angular quantities used in this topic and the angular quantities used in the circular motion topic, make sure you are clear on the distinctions between the two, for example, **angular** acceleration and **centripetal** acceleration are **not** the same thing!



Your notes

## Angular Acceleration Formula (HL)

### Angular Acceleration Formula

- The [kinematic equations of motion](#) for uniform linear acceleration can also be re-written for rotational motion
- The four kinematic equations for uniform **linear** acceleration are

$$v = u + at$$

$$s = ut + \frac{1}{2}at^2$$

$$v^2 = u^2 + 2as$$

$$s = \frac{(u + v)t}{2}$$

- This leads to the four kinematic equations for uniform **rotational** acceleration

$$\omega_f = \omega_i + \alpha t$$

$$\Delta \theta = \omega_i t + \frac{1}{2}\alpha t^2$$

$$\omega_f^2 = \omega_i^2 + 2\alpha \Delta \theta$$

$$\Delta \theta = \frac{(\omega_i + \omega_f)t}{2}$$

- The five linear variables have been swapped for the rotational equivalents, as shown in the table below

Variable	Linear	Rotational
displacement	$s$	$\theta$
initial velocity	$u$	$\omega_i$
final velocity	$v$	$\omega_f$
acceleration	$a$	$\alpha$

time	$t$	$t$
------	-----	-----



Your notes



Your notes

### Worked example

The turntable of a record player is spinning at an angular velocity of 45 RPM just before it is turned off. It then decelerates at a constant rate of  $0.8 \text{ rad s}^{-2}$ .

Determine the number of rotations the turntable completes before coming to a stop.

**Answer:**

#### Step 1: List the known quantities

- Initial angular velocity,  $\omega_i = 45 \text{ RPM}$
- Final angular velocity,  $\omega_f = 0$
- Angular acceleration,  $\alpha = 0.8 \text{ rad s}^{-2}$
- Angular displacement,  $\Delta \theta = ?$

#### Step 2: Convert the angular velocity from RPM to $\text{rad s}^{-1}$

- One revolution corresponds to  $2\pi$  radians, and RPM = revolutions per minute, so

$$\omega = 2\pi f \text{ and } f = \frac{\text{RPM}}{60} \text{ (to convert to seconds)}$$

$$\omega_i = \frac{2\pi \times \text{RPM}}{60} = \frac{2\pi \times 45}{60} = \frac{3\pi}{2} \text{ rad s}^{-1}$$

#### Step 3: Select the most appropriate kinematic equation

- We know the values of  $\omega_i$ ,  $\omega_f$  and  $\alpha$ , and we are looking for angular displacement  $\theta$ , so the best equation to use would be

$$\omega_f^2 = \omega_i^2 + 2\alpha\Delta\theta$$

#### Step 4: Rearrange and calculate the angular displacement $\Delta\theta$

$$0 = \omega_i^2 - 2\alpha\Delta\theta$$

$$\Delta\theta = \frac{\omega_i^2}{2\alpha} = \frac{\left(\frac{3\pi}{2}\right)^2}{2 \times 0.8}$$

Angular displacement,  $\Delta\theta = 13.88 \text{ rad}$

#### Step 5: Determine the number of rotations in $\Delta\theta$

- There are  $2\pi$  radians in 1 rotation

- Therefore, the number of rotations =  $\frac{13.88}{2\pi} = 2.2$

- This means the turntable spins 2.2 times before coming to a stop



Your notes



Your notes

## Moment of Inertia (HL)

### Moment of Inertia

- In linear motion, the resistance to a change of motion, i.e. linear acceleration, is known as **inertia**
  - The larger the mass an object has, the greater its inertia
- In rotational motion, the distribution of mass around an axis must be considered, using **moments of inertia**
- The moment of inertia of a rigid, extended body is defined as:
 

**The resistance to a change of rotational motion, depending on the distribution of mass around a chosen axis of rotation**
- Moment of inertia is measured in  $\text{kg m}^2$
- The moment of inertia of a body corresponds to how 'easy' or 'hard' it is to rotate, and this is dependent on many factors, including
  - Its **shape**
  - Its **density**
  - Its **orientation** (relative to an axis of rotation)
- These factors allow an object's **distribution of mass** to be taken into account
  - It also means that the moment of inertia of a singular object can **change** depending on its orientation in relation to the chosen axis of rotation
- For example, the moment of inertia of a **thin rod** is different for each of the following orientations:
  - Rotation about its **vertical axis**
  - Rotation about its **centre of mass**
  - Rotation about **one end**

EASIEST TO ROTATE

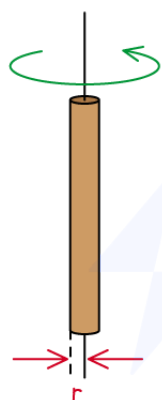

HARDEST TO ROTATE

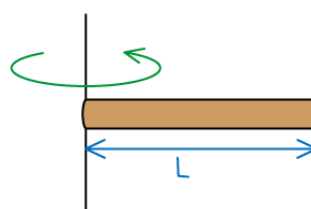

MOMENT OF INERTIA:

$$I = \frac{1}{2} mr^2$$

$$I = \frac{1}{12} mL^2$$

$$I = \frac{1}{3} mL^2$$

Copyright © Save My Exams. All Rights Reserved

***The moment of inertia of a body can change depending on its orientation relative to the axis of rotation***

- These are just a few of the possible orientations of the axis of rotation for a thin rod
  - There is an **infinite** range of possible axes, and therefore moments of inertia
  - This also applies to nearly all rigid, extended objects that could be considered

 **Examiner Tip**

Make sure you are clear on the distinction between linear motion and rotational motion here. The implications of considering the distribution of masses in relation to an axis of rotation, as opposed to considering them as uniform, have important consequences when carrying out calculations



Your notes



## Calculating Moments of Inertia

- The moment of inertia  $I$  of a point mass is equal to

$$I = mr^2$$

- Where:
  - $I$  = moment of inertia ( $\text{kg m}^2$ )
  - $m$  = mass of the object (kg)
  - $r$  = distance from its axis of rotation (m)
- A point mass is the simplest type of object to consider, the moment of inertia of a non-point mass can be calculated using

$$I = \sum mr^2$$

- This means that the sum of the moments of inertia of all the point masses in the system gives the total moment of inertia of the system
- Some moments of inertia of common shapes are shown below:



Your notes



Your notes

**SOLID**

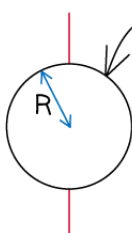

$$I = \frac{2}{5} mR^2$$

**HOLLOW**

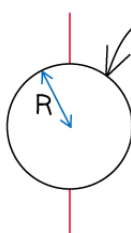

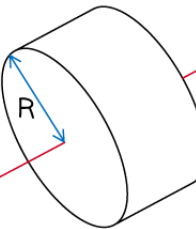
$$I = \frac{2}{3} mR^2$$

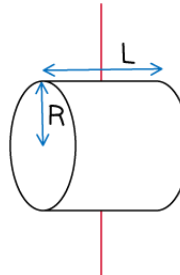
$$I = \frac{1}{2} mR^2$$

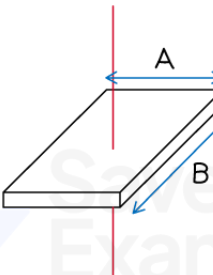
$$I = \frac{1}{4} mR^2 + \frac{1}{12} mL^2$$

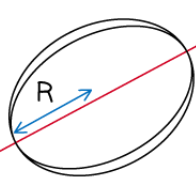
$$I = \frac{1}{12} m(A^2 + B^2)$$

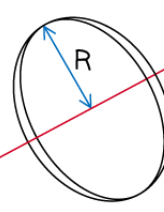
$$I = \frac{1}{2} mR^2$$

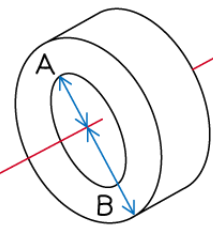
$$I = mR^2$$

$$I = \frac{1}{2} m(A^2 + B^2)$$

Copyright © Save My Exams. All Rights Reserved

Moments of inertia of common shapes, where  $R$  represents radius and  $L$  represents length, as shown



Your notes

### Worked example

Two solid spheres form a dumbbell when attached to each end of a thin rod. The dumbbell rotates with the centre of mass of each sphere at a distance of 22 cm from the axis of rotation, as shown in the diagram.

The thin rod has a mass of 20 g. Each sphere has a radius of 4 cm and a mass of 750 g.

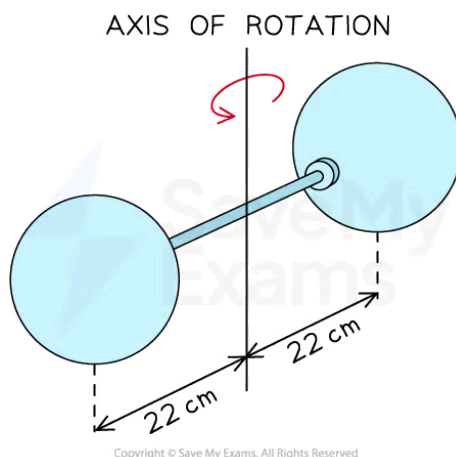

Moment of inertia of a thin rod about its centre =  $\frac{1}{12} mL^2$

Moment of inertia of a solid sphere =  $\frac{2}{5} mr^2$

Determine

- the overall moment of inertia of the dumbbell arrangement
- the ratio of the moment of inertia of the thin rod to the overall moment of inertia of the dumbbell arrangement

**Answer:**

(a)

- The overall moment of inertia of the dumbbell is the sum of all the moments of inertia in the arrangement

$$I = \sum mr^2 = 2 \times \left( \frac{2}{5} m_{\text{sphere}} r^2 \right) + \frac{1}{12} m_{\text{rod}} L^2$$

- Where:



- Mass of a sphere,  $m_{\text{sphere}} = 750 \text{ g} = 0.75 \text{ kg}$
- Distance from axis to each sphere,  $r = 22 \text{ cm} = 0.22 \text{ m}$
- Mass of the rod,  $m_{\text{rod}} = 20 \text{ g} = 0.02 \text{ kg}$
- Length of the rod,  $L = 2 \times (22 - 4) = 36 \text{ cm} = 0.36 \text{ m}$

$$I = 2 \times \left( \frac{2}{5} \times 0.75 \times 0.22^2 \right) + \left( \frac{1}{12} \times 0.02 \times 0.36^2 \right)$$

Moment of inertia of the dumbbell:  $I = 0.029 \text{ kg m}^2$

(b)

- The moment of inertia of the thin rod is

$$I_{\text{rod}} = \frac{1}{12} \times 0.02 \times 0.36^2 = 2.16 \times 10^{-4} \text{ kg m}^2$$

- Therefore, the ratio  $I_{\text{rod}} / I$  is

$$\frac{I_{\text{rod}}}{I} = \frac{2.16 \times 10^{-4}}{0.029} = 0.0071$$

- This means the rod contributes about 0.7% of the overall moment of inertia of the dumbbell

### Examiner Tip

You will never be expected to memorise the moments of inertia of different shapes, they will **always** be given in an exam question where required



Your notes

## Newton's Second Law for Rotation (HL)

### Newton's Second Law for Rotation

- In linear motion, the **force** required to give an object a certain **acceleration** depends on its **mass**

$$F = ma$$

- This is Newton's Second Law of **linear motion**, where:

- $F$  = force (N)
- $m$  = mass (kg)
- $a$  = linear acceleration ( $\text{m s}^{-2}$ )

- In rotational motion, the **torque** required to give a rotating object a certain **angular acceleration** depends on its **moment of inertia**

$$\tau = I\alpha$$

- This is Newton's Second Law of **rotational motion**, where:

- $\tau$  = torque (N m)
- $I$  = moment of inertia ( $\text{kg m}^2$ )
- $\alpha$  = angular acceleration ( $\text{rad s}^{-2}$ )

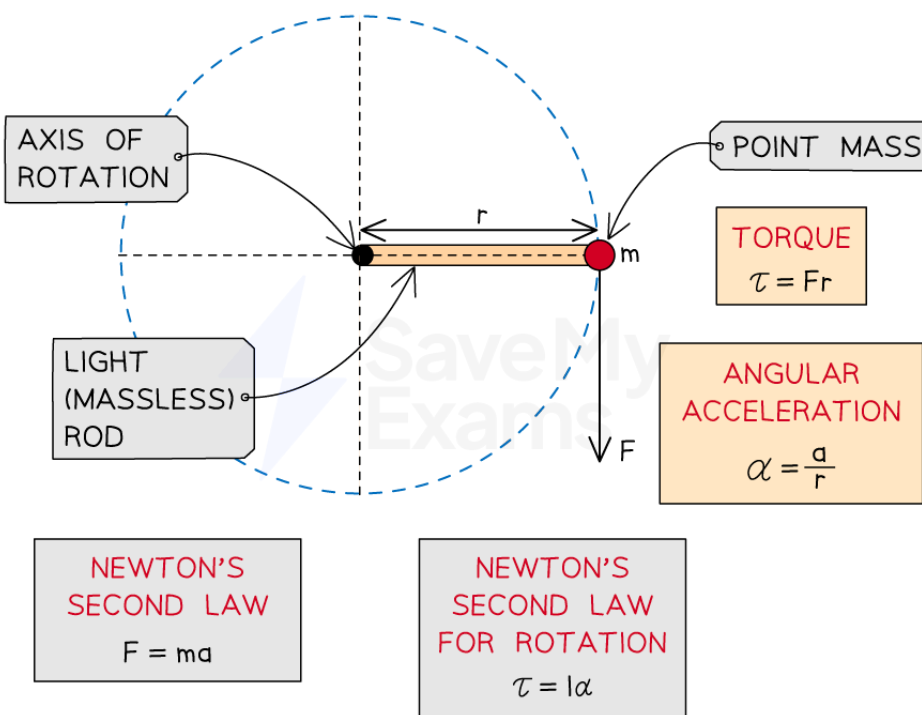

Copyright © Save My Exams. All Rights Reserved

Newton's second law for rotating bodies is equivalent to Newton's second law for linear motion



- This equation comes from the fact that **torque** is the rotational equivalent of **force**:

$$\text{Force: } F = ma$$

$$\text{Torque: } \tau = Fr$$

- Where:

- $r$  = distance from the axis of rotation (m)

- Combining these equations gives:

$$\tau = r(ma)$$

- The **moment of inertia** of a rotating body can be thought of as analogous to **mass**

- The inertia of a mass describes its ability to resist changes to **linear** motion, which is referring to **linear acceleration**
- Similarly, the moment of inertia of a mass describes its ability to resist changes to **rotational** motion, which is referring to **angular acceleration**

$$\text{Angular acceleration: } \alpha = \frac{a}{r}$$

$$\text{Moment of inertia (point mass): } I = mr^2$$

- Using these equations with the equations for force and torque leads to:

$$\tau = r(mr\alpha)$$

$$\tau = (mr^2)\alpha$$

$$\tau = I\alpha$$

### Comparison of linear and rotational variables in Newton's Second Law

Linear variable	Rotational variable
Force, $F$	Torque, $\tau$
Mass, $m$	Moment of inertia, $I$
Acceleration, $a$	Angular acceleration, $\alpha$
Newton's Second Law, $F \propto a$	Newton's Second Law, $\tau \propto \alpha$
$F = ma$	$\tau = I\alpha$



Your notes

 **Worked example**

A block of mass  $m$  is attached to a string that is wrapped around a cylindrical pulley of mass  $M$  and radius  $R$ , as shown in the diagram.

The moment of inertia of the cylindrical pulley about its axis is  $\frac{1}{2}MR^2$ .

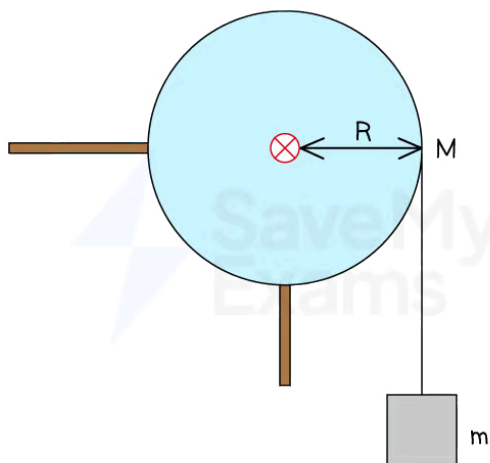

Copyright © Save My Exams. All Rights Reserved

When the block is released, the pulley begins to turn as the block falls.

Write an expression for the acceleration of the block.

**Answer:**

**Step 1: Identify the forces acting on the block**



Your notes

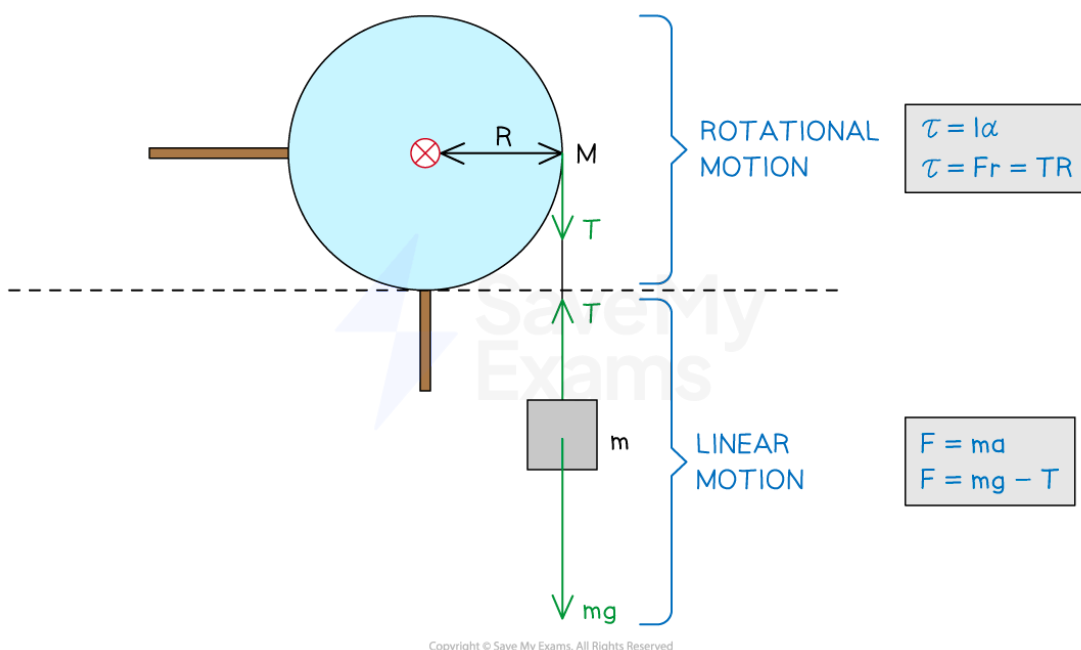

**Step 2: Apply Newton's second law to the motion of the block**

$$F = ma$$

$$mg - T = ma \text{ eq. (1)}$$

**Step 3: Apply Newton's second law to the rotation of the pulley**

$$\tau = I\alpha$$

$$TR = I\alpha$$

**Step 4: Write the equation for the pulley in terms of acceleration a**

- The angular acceleration  $\alpha$  of the pulley is:

$$\alpha = \frac{a}{R}$$

- Substitute this into the previous equation:

$$TR = I \frac{a}{R}$$

- Substitute in the expression for the moment of inertia and simplify:

Moment of inertia of the cylinder:  $I = \frac{1}{2}MR^2$





Your notes

$$TR = \left(\frac{1}{2}MR^2\right)\frac{a}{R}$$

$$T = \left(\frac{1}{2}MR^2\right)\frac{a}{R^2} = \frac{1}{2}Ma$$

$$T = \frac{1}{2}Ma \text{ eq. (2)}$$

Step 5: Substitute eq. (2) into eq. (1) and rearrange for acceleration  $a$

$$mg - \frac{1}{2}Ma = ma$$

$$mg = ma + \frac{1}{2}Ma = a\left(m + \frac{M}{2}\right)$$

Acceleration of the block:  $a = \frac{mg}{m + \frac{M}{2}}$



Your notes

## Angular Momentum (HL)

### Angular Momentum

- Angular momentum is the **rotational equivalent** of linear momentum, which is defined by mass  $\times$  velocity, or

$$p = mv$$

- Therefore, angular momentum  $L$  is defined by

$$L = I\omega$$

- Where:
  - $L$  = angular momentum ( $\text{kg m}^2 \text{ rad s}^{-1}$ )
  - $I$  = moment of inertia ( $\text{kg m}^2$ )
  - $\omega$  = angular velocity ( $\text{rad s}^{-1}$ )

### Angular Momentum of a Point Mass

- The moment of inertia of a rotating point mass  $m$  which is a distance  $r$  from an axis of rotation is equal to

$$I = mr^2$$

- The angular velocity of the point mass is given by

$$\omega = \frac{v}{r}$$

- Therefore, the angular momentum of the point mass is equal to

$$L = I\omega = (mr^2) \times \frac{v}{r} = mvr$$



Your notes

### Worked example

A horizontal rigid bar is pivoted at its centre so that it is free to rotate. A point particle of mass  $3M$  is attached at one end of the bar and a container is attached at the other end, both are at a distance of  $R$  from the central pivot.

A point particle of mass  $M$  moves with velocity  $v$  at right angles to the rod as shown in the diagram.

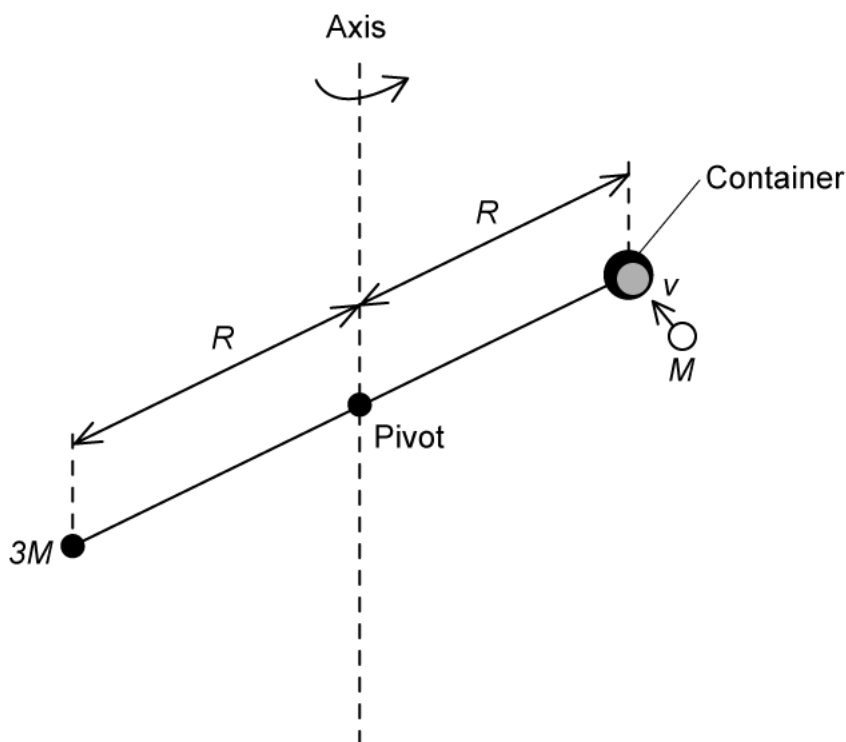

The particle collides with the container and stays within it as the system starts to rotate about the vertical axis with angular velocity  $\omega$ .

The mass of the rod and the container are negligible.

Write an expression for the angular momentum of the system about the vertical axis:

- just before the collision, in terms of  $M$ ,  $v$  and  $R$
- just after the collision, in terms of  $M$ ,  $R$  and  $\omega$ .

**Answer:**

**(a)** Just before the collision:



Your notes

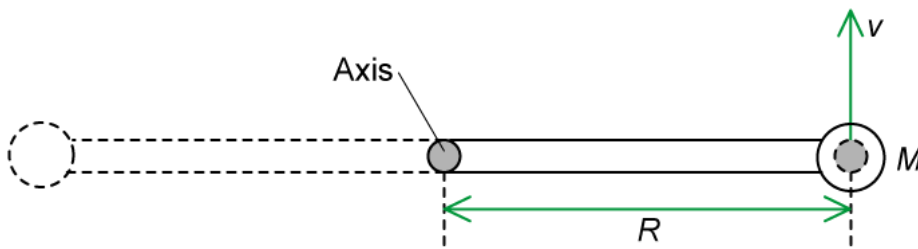

- Angular momentum is equal to:

$$L = I\omega$$

- The moment of inertia of a point particle is

$$I = mr^2$$

- Linear velocity is related to angular velocity by

$$v = \omega r$$

- The rod, container and  $3M$  mass are all stationary before the collision, so we only need to consider the angular momentum of the point particle

- Where:

- Mass of the particle,  $m = M$
- Distance of the particle from the axis,  $r = R$
- Angular velocity of the particle,  $\omega = \frac{v}{R}$

- Therefore, the angular momentum of the system before the collision is:

$$L = (MR^2) \times \frac{v}{R} = MvR$$

(b) After the collision:

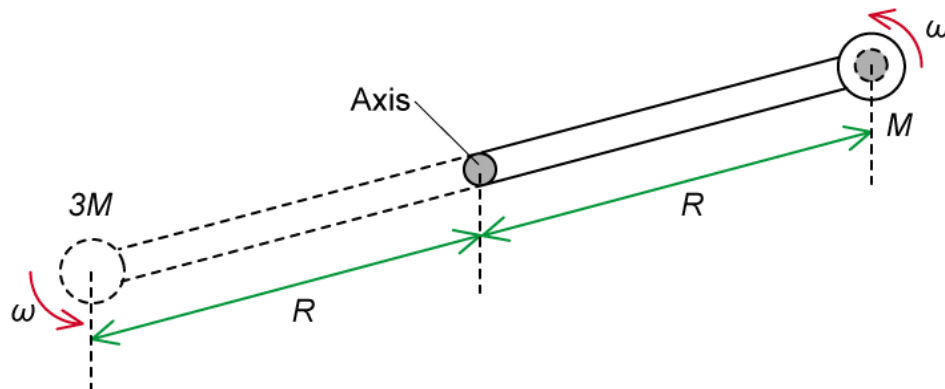

- The whole system rotates with an angular velocity of  $\omega$
- We are considering the rod and the container as massless, so we only need to consider the angular momentum of the two masses  $M$  and  $3M$
- Therefore, the angular momentum of the system after the collision is:

$$L = (MR^2)\omega + (3MR^2)\omega$$

$$L = 4MR^2\omega$$

### Examiner Tip

You should know that objects travelling in straight lines **can** have angular momentum – just make sure you understand that it all depends on the position of the object in relation to the axis of rotation being considered



IF THERE IS NO SPECIFIED AXIS, WE CAN'T SAY IF THE PARTICLE HAS ANGULAR MOMENTUM

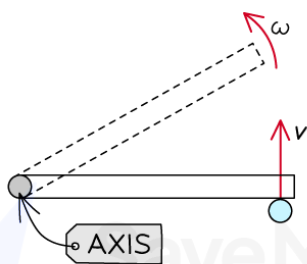

THE PARTICLE CAUSES THE ROD TO ROTATE, SO IT MUST HAVE ANGULAR MOMENTUM RELATIVE TO THE AXIS

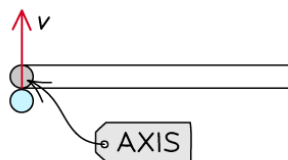

IF THE PARTICLE HITS THE AXIS, IT WILL NOT CAUSE ANY ROTATION

Copyright © Save My Exams. All Rights Reserved



Your notes

## Conservation of Angular Momentum

- As with linear momentum, angular momentum is **always conserved**
- The principle of conservation of angular momentum states:
 

**The angular momentum of a system always remains constant, unless a net torque is acting on the system**
- This conservation law has many real-world applications, for example
  - A person on a **spinning chair** spins faster while their arms and legs are contracted and slower while extended
  - Objects in **elliptical orbits** travel faster nearer the object they orbit and slower when further away
  - Ice skaters** can change their rotation velocity by extending or contracting their arms
  - Tornados** spin faster as their radius decreases

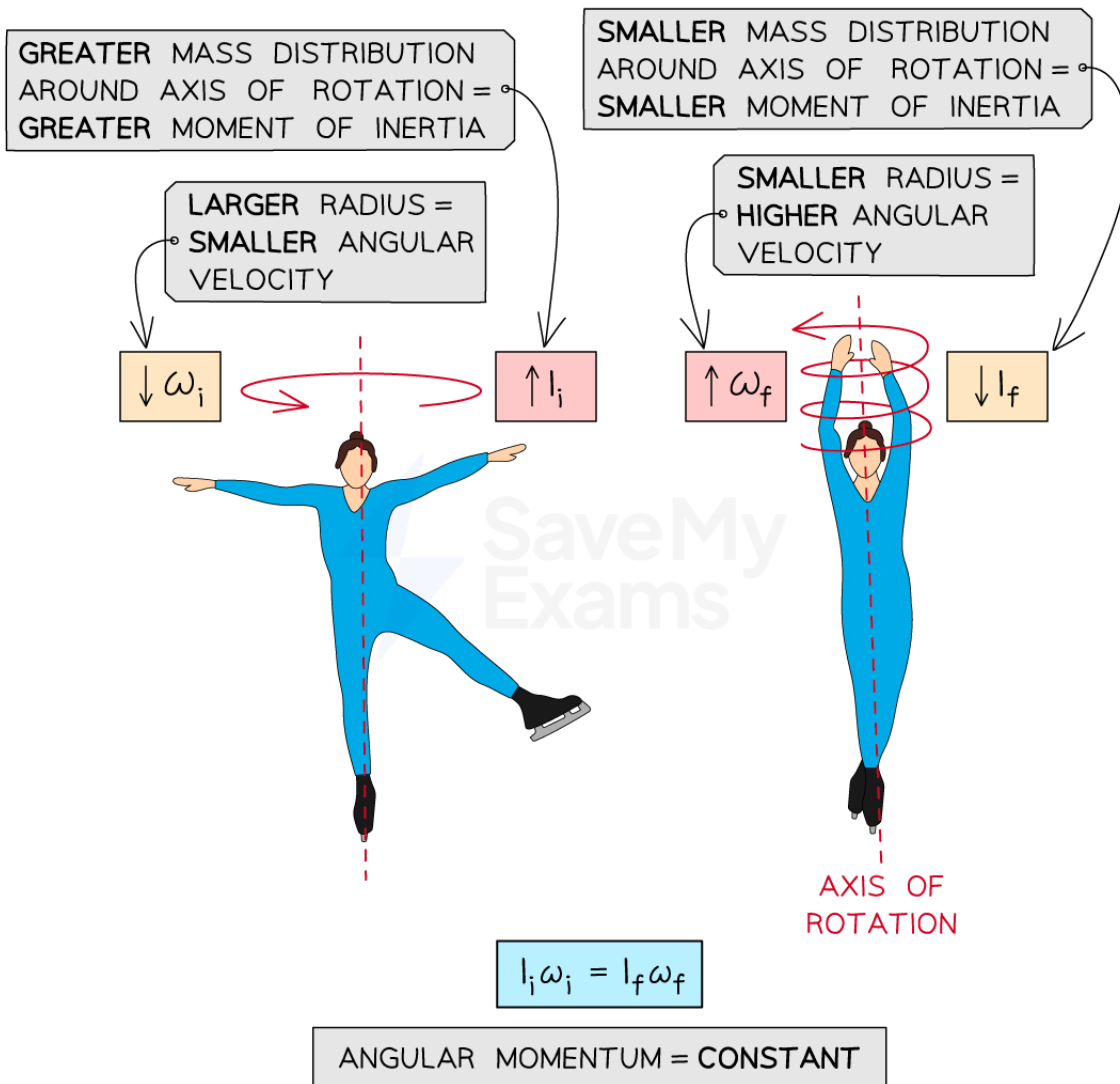

Copyright © Save My Exams. All Rights Reserved

*Ice skaters can change their moment of inertia by extending or contracting their arms and legs. Due to conservation of angular momentum, this allows them to spin faster or slower*

- Problems involving a **constant angular momentum** can be solved using the equation:

$$I_i \omega_i = I_f \omega_f$$

- Where:

- $I_i$  = initial moment of inertia ( $\text{kg m}^2$ )
- $\omega_i$  = initial angular velocity ( $\text{rad s}^{-1}$ )
- $I_f$  = final moment of inertia ( $\text{kg m}^2$ )
- $\omega_f$  = final angular velocity ( $\text{rad s}^{-1}$ )



Your notes



Your notes

 **Worked example**

The diagram shows the different positions of a diver between jumping off a springboard and entering the water.

During their fall, the diver pulls their arms and legs into a tight tuck position while in the air and straightens them before entering the water.

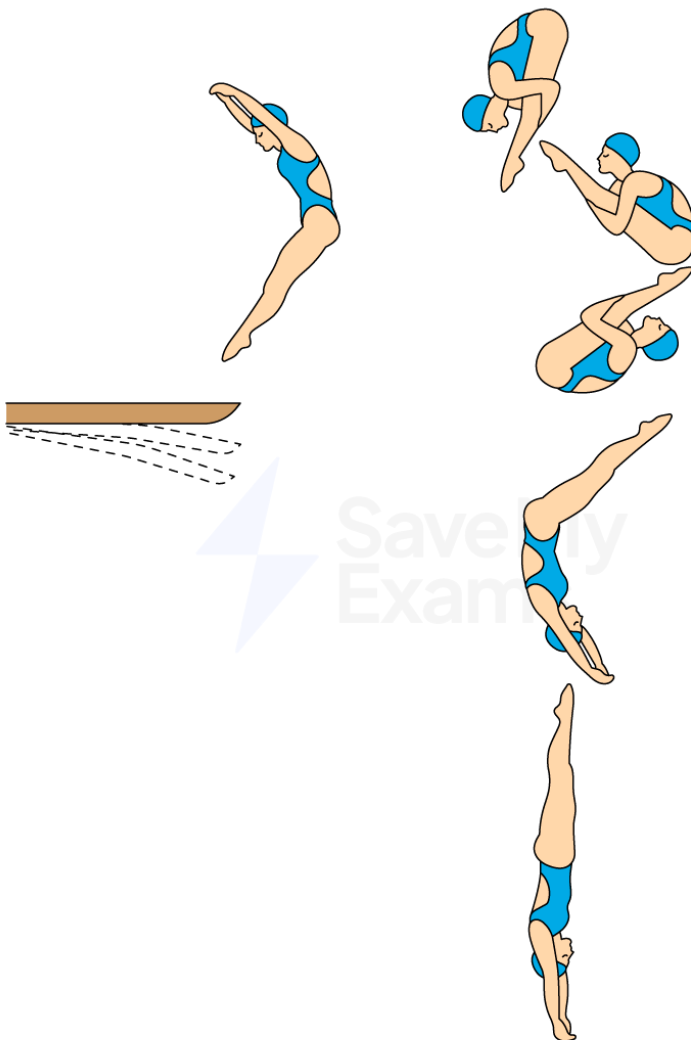

Copyright © Save My Exams. All Rights Reserved

Which row correctly describes the changes to the diver's moment of inertia and angular velocity as they bring their limbs closer to their body?

	moment of inertia	angular velocity



A.	increases	increases
B.	decreases	increases
C.	increases	decreases
D.	decreases	decreases

Answer: **B**

- After the diver leaves the springboard, there is no longer a resultant torque acting on them
  - This means their angular momentum remains **constant** throughout the dive
- Due to the conservation of angular momentum:

$$I_i \omega_i = I_f \omega_f = \text{constant}$$

- When the diver tucks their arms and legs in closer to their body, they **decrease** their moment of inertia
  - This eliminates options **A & C**
- Therefore, to conserve angular momentum, when the diver's moment of inertia decreases, their angular velocity must **increase**



Your notes



Your notes

### Worked example

A spherical star of mass  $M$  and radius  $R$  rotates about its axis. The star explodes, ejecting mass in space radially and symmetrically. The remaining star is left with a mass of  $\frac{1}{10}M$  and a radius of  $\frac{1}{50}R$ .

Calculate the ratio of the star's final angular velocity to its initial angular velocity.

The moment of inertia of a sphere is  $\frac{2}{5}MR^2$

**Answer:**

- Before the star explodes:

- Initial moment of inertia,  $I_i = \frac{2}{5}MR^2$

- Initial angular velocity =  $\omega_i$

- After the star explodes:

- Final moment of inertia,  $I_f = \frac{2}{5}\left(\frac{1}{10}M\right)\left(\frac{1}{50}R\right)^2$

- Final angular velocity =  $\omega_f$

- From the conservation of angular momentum:

$$I_i \omega_i = I_f \omega_f$$

$$\left(\frac{2}{5}MR^2\right)\omega_i = \left(\frac{2}{5} \times \frac{1}{10}M \times \left(\frac{1}{50}\right)^2 R^2\right)\omega_f$$

$$\left(\frac{2}{5}MR^2\right)\omega_i = \left(\frac{2}{5}MR^2\right)\frac{1}{25000}\omega_f$$

- Therefore, the ratio of the star's final angular velocity to its initial angular velocity is:

$$\frac{\omega_f}{\omega_i} = 25000$$



Your notes

## Angular Impulse (HL)

### Angular Impulse

- In linear motion, the **resultant force** on a body can be defined as the rate of change of linear momentum:

$$F = \frac{\Delta p}{\Delta t}$$

- This leads to the definition of linear impulse:

An average resultant force  $F$  acting for a time  $\Delta t$  produces a change in linear momentum  $\Delta p$

$$\Delta p = F\Delta t = \Delta(mv)$$

- Similarly, the **resultant torque** on a body can be defined as the rate of change of angular momentum:

$$\tau = \frac{\Delta L}{\Delta t}$$

- Where:

- $\tau$  = resultant torque on a body (N m)
- $\Delta L$  = change in angular momentum ( $\text{kg m}^2 \text{s}^{-1}$ )
- $\Delta t$  = time interval (s)

- This leads to the definition of angular impulse:

An average resultant torque  $\tau$  acting for a time  $\Delta t$  produces a change in angular momentum  $\Delta L$

$$\Delta L = \tau\Delta t = \Delta(I\omega)$$

- Angular impulse is measured in  $\text{kg m}^2 \text{s}^{-1}$ , or N m s
- This equation requires the use of a **constant** resultant torque
  - If the resultant torque changes, then an **average** of the values must be used
- Angular impulse describes the effect of a torque acting over a time interval
  - This means a **small torque** acting over a **long time** has the same effect as a **large torque** acting over a **short time**

### Angular Impulse on a Torque–Time Graph

- The area under a torque–time graph is equal to the angular impulse or the change in angular momentum

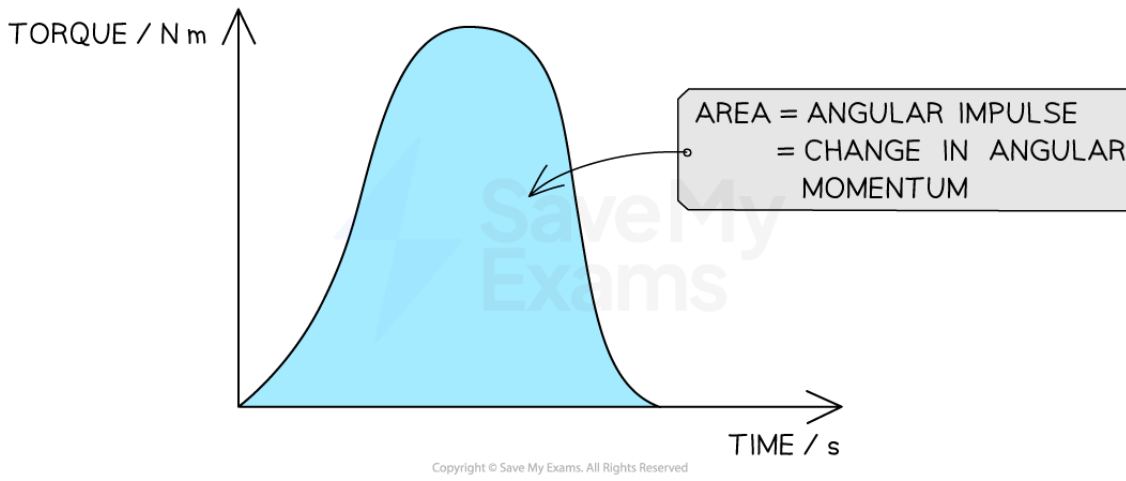

Your notes

**When the torque is not constant, the angular impulse is the area under a torque–time graph**



Your notes

### Worked example

The graph shows the variation of time  $t$  with the net torque  $\tau$  on an object which has a moment of inertia of  $5.0 \text{ kg m}^2$ .

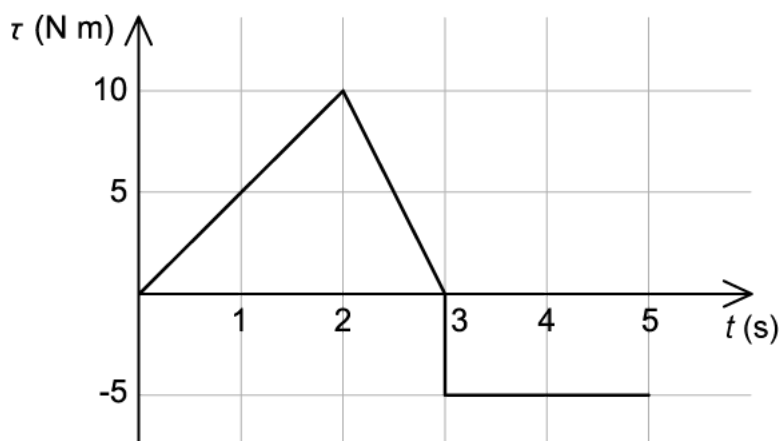

At  $t = 0$ , the object rotates with an angular velocity of  $2.0 \text{ rad s}^{-1}$  clockwise.

Determine the magnitude and direction of rotation of the angular velocity at  $t = 5 \text{ s}$ .

In this question, take anticlockwise as the positive direction.

**Answer:**

**Step 1: Use the graph to determine the angular impulse**

- The area under a torque-time graph is equal to angular impulse, or the change in angular momentum

$$\Delta L = \tau \times \Delta t$$



Your notes

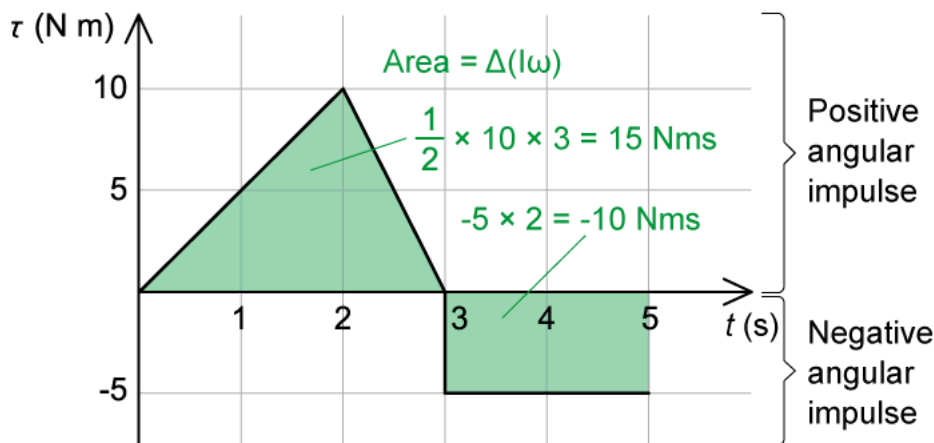

- The area under the positive curve (triangle) =  $\frac{1}{2} \times 10 \times 3 = 15 \text{ N m s}$
- The area under the negative curve (rectangle) =  $-5 \times 2 = -10 \text{ N m s}$
- Therefore, the angular impulse, or change in angular momentum is
 
$$\Delta L = 15 - 10 = 5 \text{ N m s}$$

### Step 2: Write an expression for the change in angular momentum

- The change in angular momentum is equal to
 
$$\Delta L = \Delta(I\omega) = I(\omega_f - \omega_i)$$
- Where
  - Moment of inertia,  $I = 5.0 \text{ kg m}^2$
  - Initial angular velocity,  $\omega_i = -2.0 \text{ rad s}^{-1}$  (clockwise is the negative direction)

### Step 3: Calculate the final angular velocity

- Therefore, when  $t = 5 \text{ s}$ , the angular velocity is
 
$$5 \times (\omega_f - (-2)) = 5$$

$$\omega_f = -1.0 \text{ rad s}^{-1} \text{ in the clockwise direction}$$



Your notes

## Rotational Kinetic Energy (HL)

### Rotational Kinetic Energy

- A body moving with **linear velocity** has an associated linear kinetic energy given by

$$E_k = \frac{1}{2}mv^2$$

$$E_k = \frac{p^2}{2m}$$

- Similarly, a rotating body with **angular velocity** has an associated **rotational kinetic energy** given by

$$E_k = \frac{1}{2}I\omega^2$$

$$E_k = \frac{L^2}{2I}$$

- Where:
  - $E_k$  = rotational kinetic energy (J)
  - $I$  = moment of inertia ( $\text{kg m}^2$ )
  - $\omega$  = angular velocity ( $\text{rad s}^{-1}$ )
  - $L$  = angular momentum ( $\text{kg m}^2 \text{s}^{-1}$ )

### Rolling without slipping

- Circular objects, such as wheels, are made to move with **both** linear and rotational motion
  - For example, the wheels of a car, or bicycle **rotate** causing it to move **forward**
- Rolling motion without slipping is a combination of **rotating** and **sliding** (translational) motion
- When a disc **rotates**:
  - Each point on the disc has a **different** linear velocity depending on its distance from the centre ( $v \propto r$ )
  - The linear velocity is the **same** at all points on the **circumference**
- When a disc **slips**, or **slides**:
  - There is **not enough friction** present to allow the object to roll
  - Each point on the object has the **same** linear velocity
  - The angular velocity is **zero**
- So, when a disc **rolls without slipping**:
  - There is enough **friction** present to initiate rotational motion allowing the object to roll
  - The point in contact with the surface has a **velocity of zero**
  - The centre of mass has a velocity of  $v = \omega r$



Your notes

- The top point has a velocity of  $2v$  or  $2\omega r$

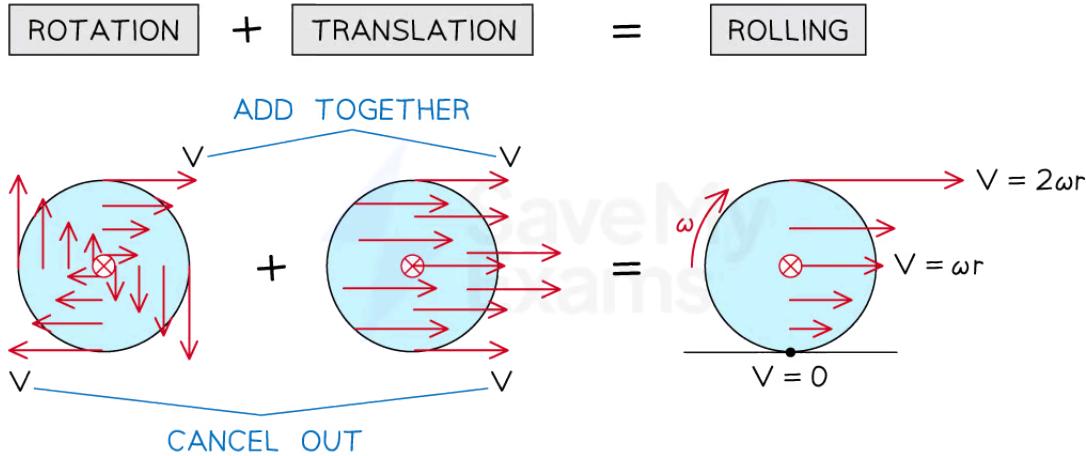

**Rolling motion is a combination of rotational and translational motion. The resultant velocity at the bottom is zero and the resultant velocity at the top is  $2v$**

### Rolling down a slope

- Another common scenario involving rotational and translational motion is an object (usually a ball or a disc) **rolling down a slope**
- At the **top** of the slope, a stationary object will have gravitational potential energy equal to

$$E_p = mg\Delta h$$

- As the object **rolls** down the slope, the gravitational potential energy will be transferred to **both** translational (linear) and rotational kinetic energy
- At the **bottom** of the slope, the **total kinetic energy** of the object will be equal to

$$E_{K \text{ total}} = \frac{1}{2}mv^2 + \frac{1}{2}I\omega^2$$



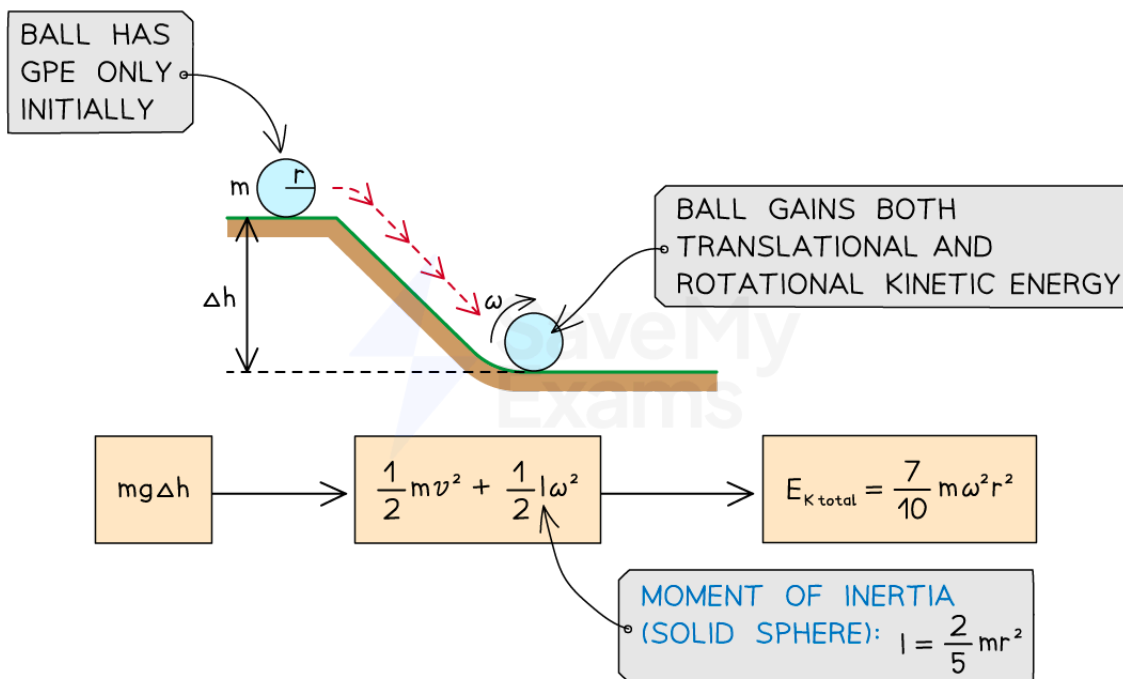

Copyright © Save My Exams. All Rights Reserved

- The linear or angular velocity can then be determined by
  - Equating  $E_p$  and  $E_{K\ total}$
  - Using the equation for the moment of inertia of the object
  - Using the relationship between linear and angular velocity  $v = \omega r$
- For example, for a ball (a solid sphere) of mass  $m$  and radius  $r$ , its moment of inertia is

$$I = \frac{2}{5} mr^2$$

- Equating the equations for  $E_p$  and  $E_{K\ total}$  and simplifying gives

$$mg\Delta h = \frac{1}{2}m(\omega r)^2 + \frac{1}{2}\left(\frac{2}{5}mr^2\right)\omega^2$$

$$mg\Delta h = \frac{1}{2}m\omega^2 r^2 + \frac{1}{5}m\omega^2 r^2$$

$$mg\Delta h = \frac{7}{10}m\omega^2 r^2$$



Your notes

 **Worked example**

A flywheel of mass  $M$  and radius  $R$  rotates at a constant angular velocity  $\omega$  about an axis through its centre. The rotational kinetic energy of the flywheel is  $E_K$ .

The moment of inertia of the flywheel is  $\frac{1}{2}MR^2$ .

A second flywheel of mass  $\frac{1}{2}M$  and radius  $\frac{1}{2}R$  is placed on top of the first flywheel. The new angular velocity of the combined flywheels is  $\frac{2}{3}\omega$ .

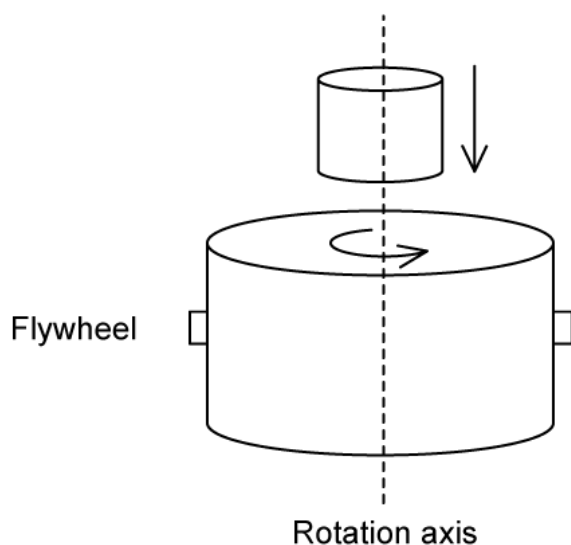

What is the new rotational kinetic energy of the combined flywheels?

- A.  $\frac{E_K}{2}$     B.  $\frac{E_K}{4}$     C.  $\frac{E_K}{8}$     D.  $\frac{E_K}{24}$

**Answer: A**

- The kinetic energy of the first flywheel is

$$E_K = \frac{1}{2}I\omega^2 = \frac{1}{2} \times \left(\frac{1}{2}MR^2\right) \times \omega^2$$



Your notes

$$E_K = \frac{1}{4}MR^2\omega^2$$

- The combined flywheels have a total moment of inertia of

$$I_{new} = I_1 + I_2$$

$$I_{new} = \frac{1}{2}MR^2 + \frac{1}{2}\left(\frac{1}{2}M\right)\left(\frac{1}{2}R\right)^2$$

$$I_{new} = \frac{9}{16}MR^2$$

- The kinetic energy of the combined flywheels is

$$E_{K_{new}} = \frac{1}{2}I_{new}\omega_{new}^2 = \frac{1}{2} \times \left(\frac{9}{16}MR^2\right) \times \left(\frac{2}{3}\omega\right)^2$$

$$E_{K_{new}} = \frac{1}{2} \times \left(\frac{1}{4}MR^2\omega^2\right) = \frac{1}{2}E_K$$