

Structured Questions

5.3 Electric Cells

5.3.1 Primary & Secondary Cells / 5.3.2 Investigating Electric Cells / 5.3.3 Terminal Potential Difference / 5.3.4 Electromotive Force & Internal Resistance

Easy (5 questions)	/62
Medium (5 questions)	/57
Hard (4 questions)	/48
Total Marks	/167

Scan here to return to the course
or visit [savemyexams.com](https://www.savemyexams.com)

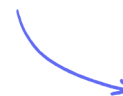

Easy Questions

1 (a) Cells used in circuits can be divided into two groups, primary cells and secondary cells.

Define a primary cell and state an example.

(2 marks)

(b) Define a secondary cell and state an example.

(3 marks)

(c) For the following descriptions of the functions of primary and secondary cells, choose the correct words from each pair in bold to complete the sentences.

During normal operation of a primary cell, the electrons flow from the **negative/positive** plate of the cell, around the circuit, to the **negative/positive** plate of the cell.

When recharging a secondary cell, the electrons are forced from the **negative/positive** plate to the **negative/positive** plate by an external current.

(2 marks)

(d) Lithium cells are widely used and have allowed for a revolution in the manufacture of portable electronics. However there are concerns with reliance on lithium as a material for making cells.

Outline two concerns with the use of lithium in cells.

(2 marks)

2 (a) The electromotive force, ε is defined by the equation

$$\varepsilon = I(R + r)$$

Define the following variables and state an appropriate unit for each.

(i) I [1]

(ii) R [1]

(iii) r [1]

.....

.....

.....

(3 marks)

(b) The circuit shown includes a cell with internal resistance and a load resistor.

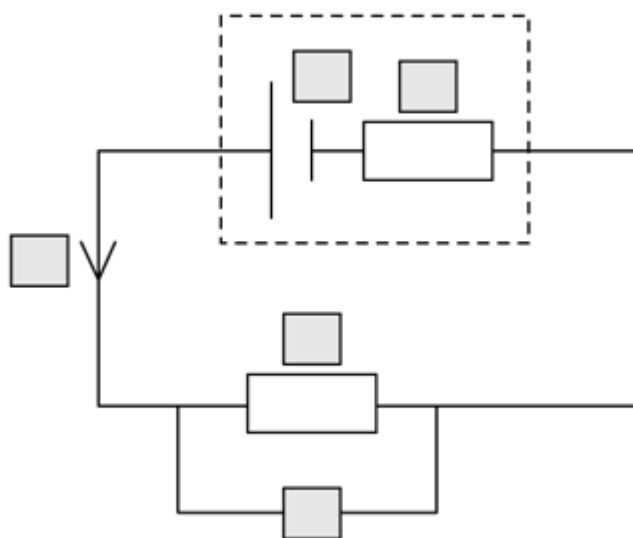

Complete the labels on the components using each of the following variables once only.

ϵ I r R V

(5 marks)

- (c) A current of 0.6 mA flows through the circuit in part (a) and the resistor has a resistance of 2.5 k Ω .

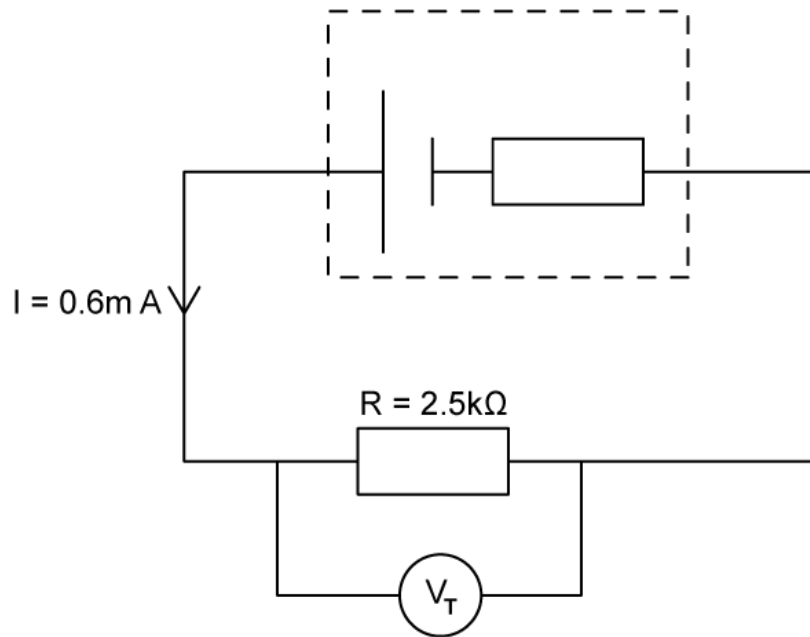

Calculate the terminal potential difference V_T of the circuit.

(3 marks)

(d) The internal resistance of the cell is $1.3 \text{ k}\Omega$.

Calculate the emf of the cell.

(3 marks)

3 (a) Explain what is meant by the electromotive force of a cell and state the units.

(4 marks)

(b) Define the internal resistance of a cell.

(1 mark)

(c) In the circuit shown a high resistance voltmeter is used to measure the potential difference across the terminals of a battery.

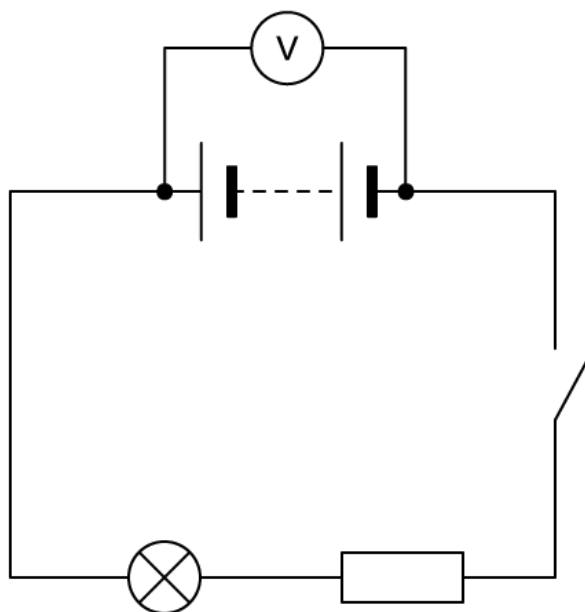

The switch is closed.

(i) State how the voltmeter reading changes.

[1]

(ii) Explain what property of the battery causes this change.

[1]

(2 marks)

(d) Explain why the voltmeter reading changes when the switch is closed.

(1 mark)

- 4 (a) To investigate the internal resistance and emf of a cell a student uses the circuit shown. The cell has emf ϵ and internal resistance r and is connected in series to a variable resistor with resistance R .

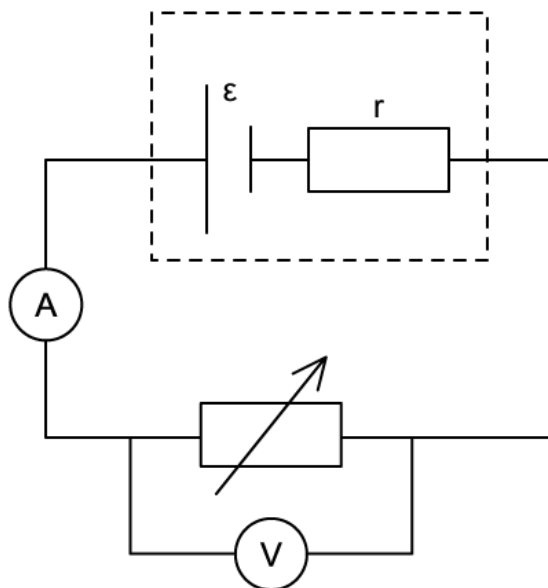

The student wishes to determine the relationship between the voltmeter and ammeter readings whilst decreasing R . Their results are given.

Terminal potential difference / V	Current / A
8.3	0.07
6.8	0.17
4.6	0.33
2.9	0.44
0.3	0.63

Plot a graph of the data using the graph layout given below.

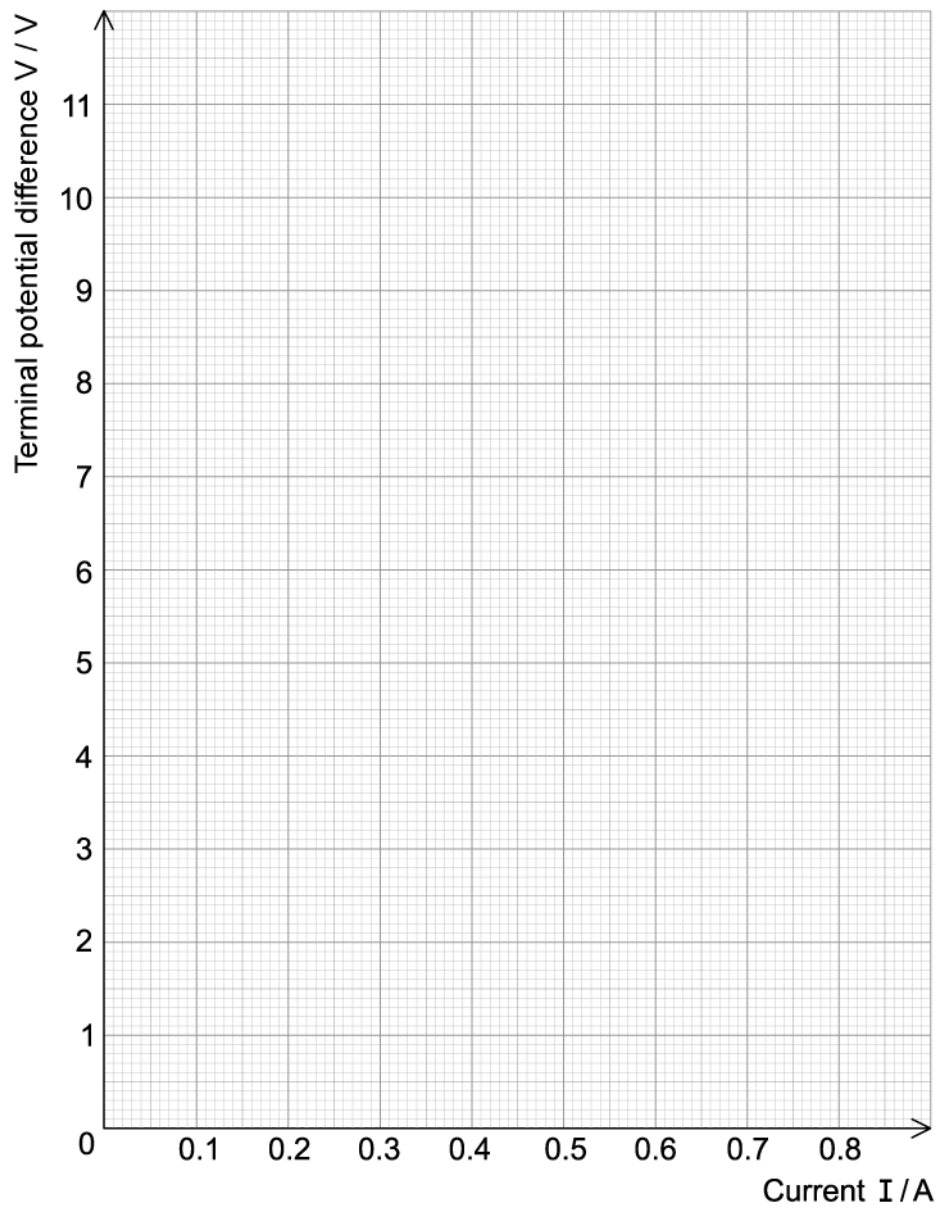

(3 marks)

(b) Using your graph from part (a) (or the model solution provided)

(i) Determine the value of ϵ . [1]

(ii) Explain your method. [1]

.....

.....

(2 marks)

(c) Using your graph from part (a) (or the model solution provided) calculate the value of r . Show your method clearly.

.....

.....

.....

.....

(4 marks)

(d) Using your graph from part (a) (or the model solution provided) sketch a line to show the results obtained from a cell with:

(i) The same emf but larger internal resistance. Label this A. [2]

(ii) The same internal resistance but larger emf. Label this B. [2]

.....

.....

.....

.....

(4 marks)

5 (a) The circuit shown is used to test a battery of four identical cells each with emf $\varepsilon = 0.70 \text{ V}$.

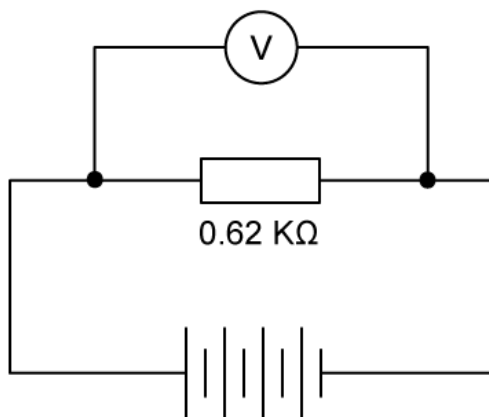

A fixed resistor with $R = 0.62 \text{ k}\Omega$ is connected in series with the cell. A current $I = 4.50 \text{ mA}$ travels through the circuit.

For this circuit

- (i) Calculate the emf of the battery. [2]
- (ii) Calculate the internal resistance of the battery. [3]
- (iii) State an appropriate unit for your answer. [1]

.....

.....

.....

.....

.....

.....

(6 marks)

(b) For the circuit in part (a), calculate the internal resistance of one cell.

.....

(c) As cells are used they discharge their voltage, according to a curve as shown.

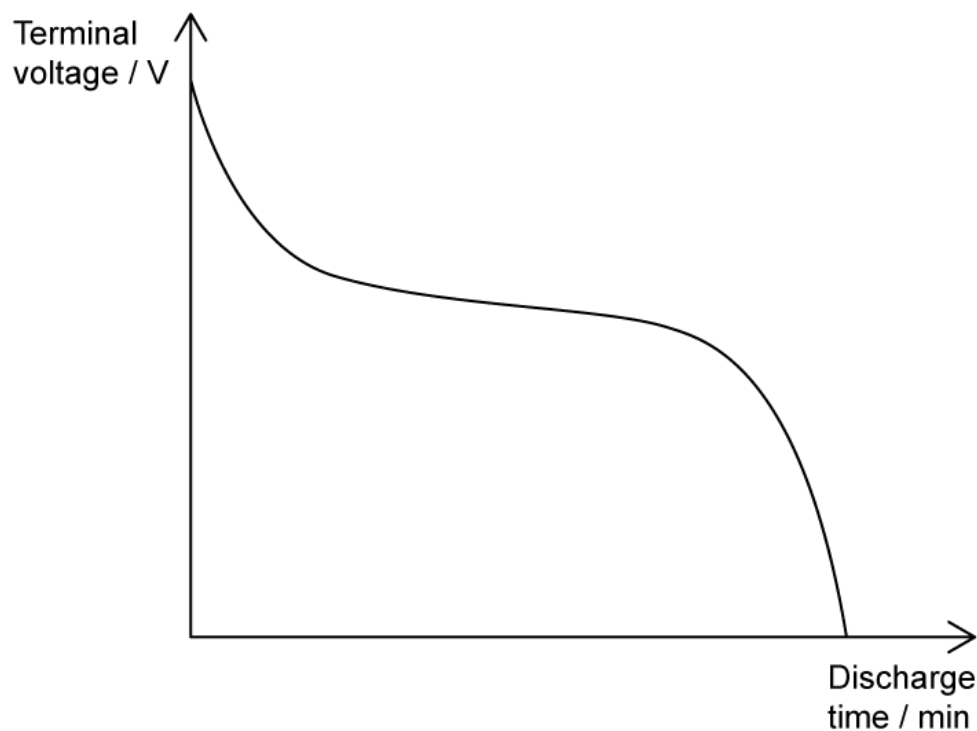

To describe the graph, choose the correct word from each pair.

- When a cell is discharging, it **will/will not** discharge a constant amount of voltage.
- When the cell is new the initial high voltage will begin to discharge **slowly/fairly quickly**.
- For most of the life of the cell it discharges **slowly/fairly quickly**.
- Finally, as the cell reaches the end of its life the voltage is discharged **slowly/fairly quickly**.

(4 marks)

- (d)** The graph in part (c) represents a 1.5 V AA battery discharging over time. The battery is connected so that the circuit draws a current of 2.0 A.

Using the graph from part (c), add discharge curves for two identical cells which are drawing different currents. Label your lines (i) and (ii).

(i) Current, $I = 1.0 \text{ A}$

[3]

(ii) Current, $I = 4.0 \text{ A}$

[3]

(6 marks)

Medium Questions

- 1 (a) The diagram below shows two circuits A and B that were used by a student to test a battery of four identical cells. In circuit A, there was no load resistor and in circuit B a load resistor was connected. Assume that the meters in the circuits are ideal.

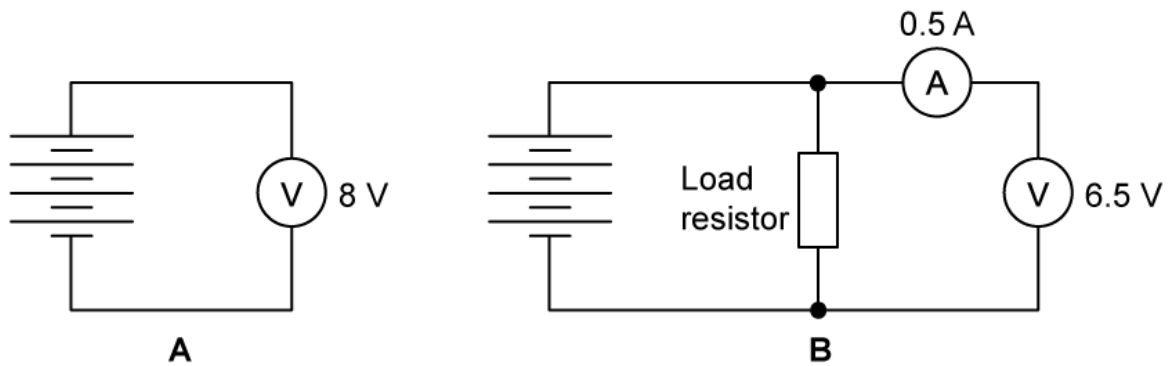

Explain why there is a difference in voltages recorded in the two circuits.

.....

.....

.....

(3 marks)

- (b) Calculate the internal resistance of a single cell.

.....

.....

.....

(3 marks)

- (c) In circuit B, the resistance of the load resistor R is altered so that a series of values on the voltmeter and the corresponding values of the current on the ammeter are obtained.

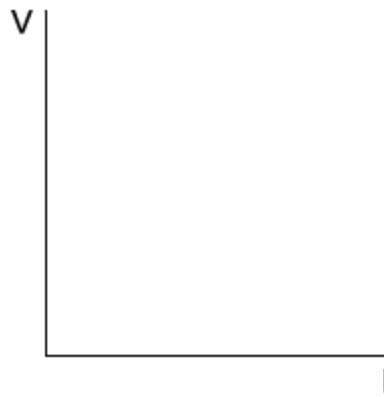

(i) On the axes above, sketch the graph you would expect to obtain as R is changed.

[2]

(ii) Outline how the values of ε and r can be obtained from the graph.

[2]

(4 marks)

(d) A cell is connected to an external resistor and the terminal voltage across the cell monitored. The graph shows the discharge time for one cell with a current of 0.5 A.

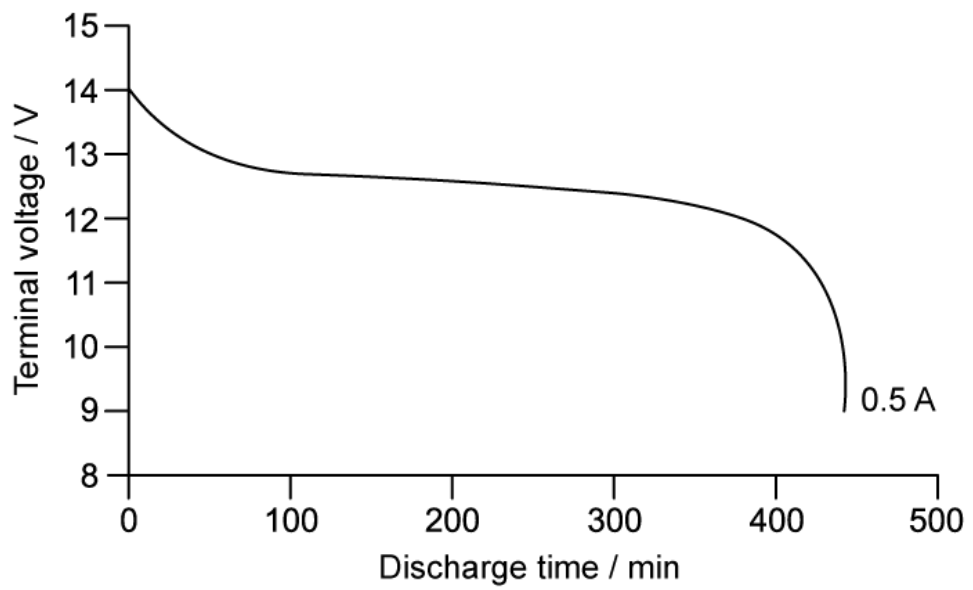

Determine the terminal voltage of the single cell. Show your working clearly.

(2 marks)

2 (a) The diagram shows a battery of e.m.f. 40.0 V and internal resistance, r .

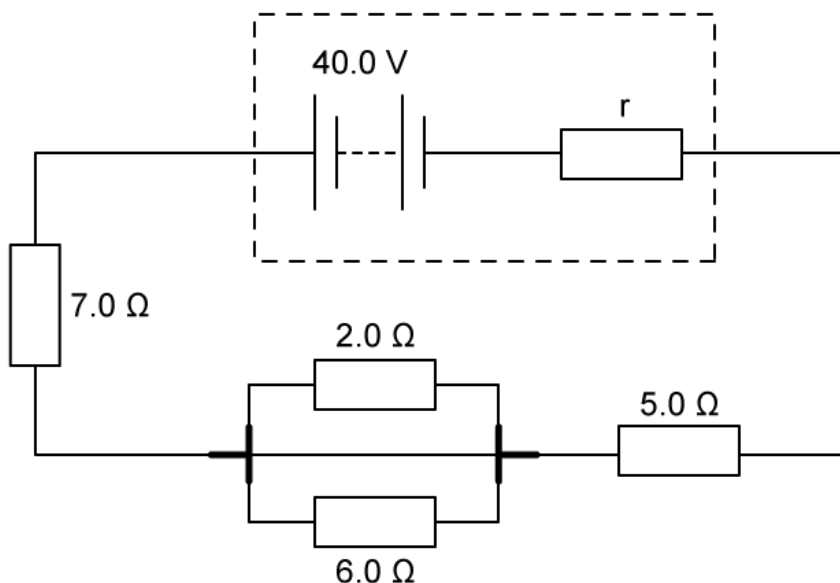

The current in the battery is 2.5 A.

Calculate the internal resistance r .

(4 marks)

(b) Calculate the energy dissipated in the battery in 3.5 minutes.

(2 marks)

(c) The circuit is amended to include a primary and a secondary cell.

Explain the function of primary and secondary cells and the role they have in an electric circuit.

(3 marks)

- (d)** The internal resistance of the battery affects the efficiency of the transfer of energy from the battery to the circuit.

Explain what causes internal resistance and why this affects the efficiency of the battery.

(3 marks)

- 3 (a) The diagram shows a cell of e.m.f. ϵ , and internal resistance, r , is connected to a variable resistor R . The current through the cell and the terminal p.d. of the cell are measured as R is decreased.

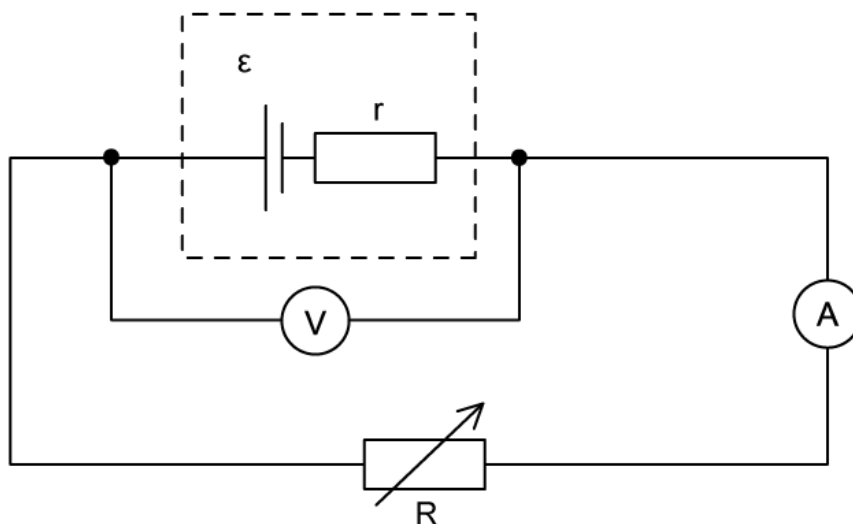

The graph below shows the results from the experiment.

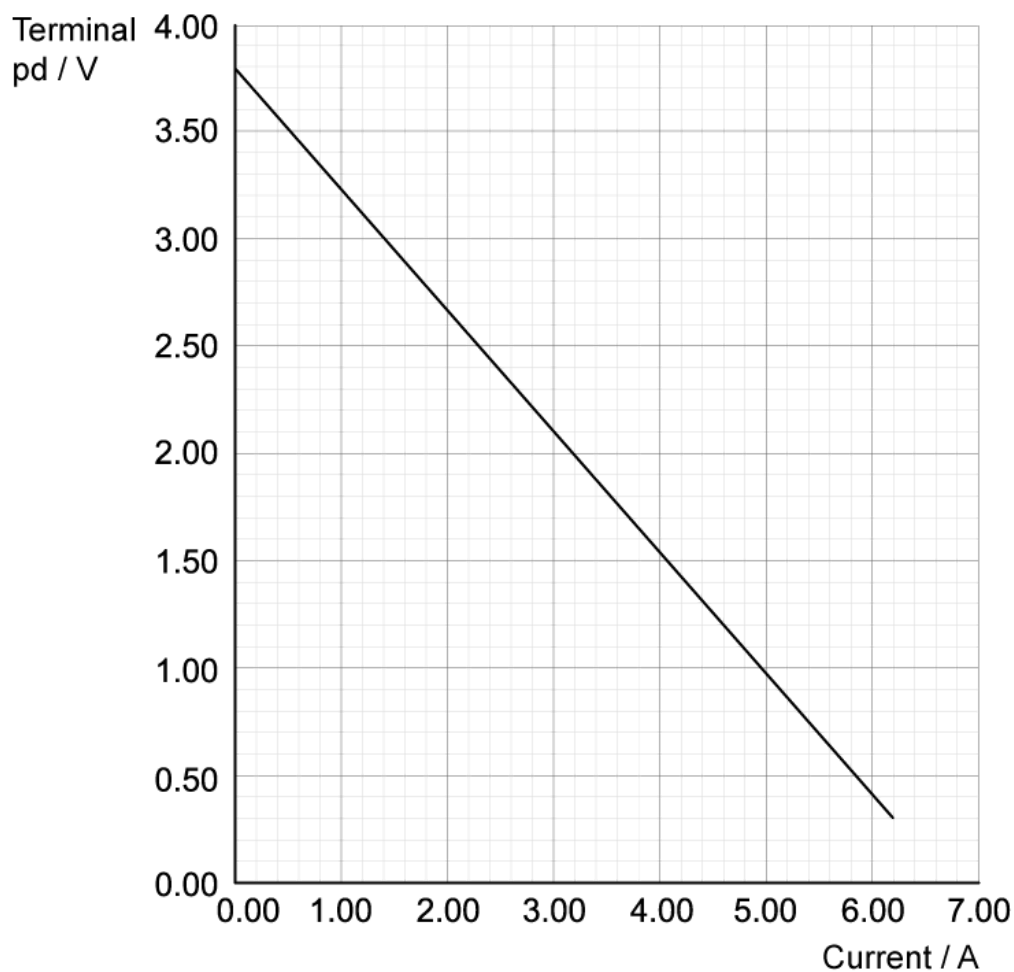

State the relationship between the terminal p.d. and current and explain why this relationship occurs.

.....

.....

.....

(3 marks)

(b) Find the e.m.f., ϵ , and the internal resistance, r , of the cell.

.....

.....

.....

(3 marks)

(c) Draw a line on the graph above to show the results obtained from a cell with the half the e.m.f. but double the internal resistance of the first cell. Label your graph **A**.

.....

.....

(2 marks)

(d) Draw a line on the same graph to show the results obtained from a cell with the same e.m.f. but negligible internal resistance. Label your graph **B**.

.....

.....

(2 marks)

4 (a) A battery is connected to an 9.0Ω resistor. The e.m.f. of the battery is 12 V .

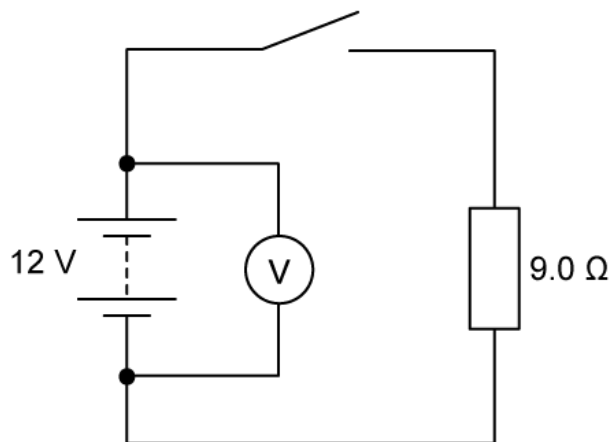

When the switch is open the voltmeter reads 12 V and when it is closed it reads 11.3 V .

Explain why the readings are different.

.....

.....

.....

(3 marks)

(b) Calculate the internal resistance of the battery.

.....

.....

.....

(3 marks)

(c) The circuit diagram shows that the 9.0Ω resistor is now connected in parallel with an unknown resistor, R . The battery now supplies a current of 3.0 A and has the same internal resistance r as the previous circuit.

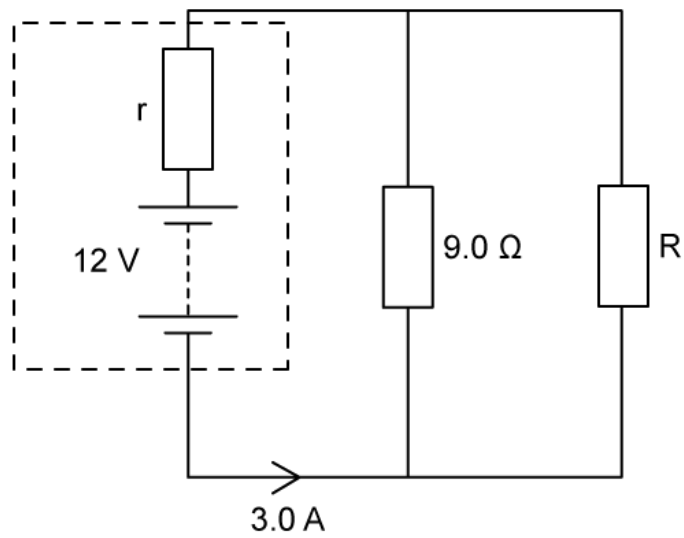

Calculate the p.d. across the 9.0Ω resistor.

.....

.....

(2 marks)

(d) Calculate the resistance of R .

.....

.....

.....

(3 marks)

- 5 (a) A very high resistance voltmeter reads 11.5 V when it is connected across the terminals of a power supply.

Explain why the reading on the voltmeter is equal to the E.m.f. of the power supply.

(3 marks)

A battery of e.m.f. 11.5 V and internal resistance r is connected in a circuit with three identical $13\ \Omega$ resistors. A current of 0.40 A flows through the battery.

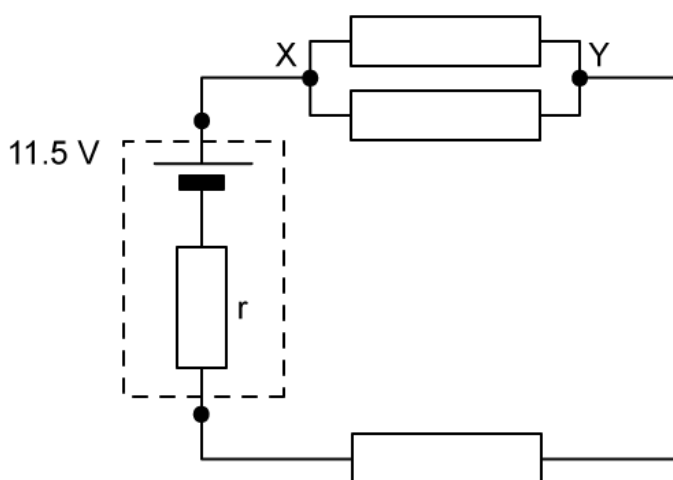

- (b) Calculate the potential difference between points X and Y in the circuit.

(2 marks)

- (c) Calculate the internal resistance of the battery.

(3 marks)

(d) Explain the direction of the current flow required to recharge the secondary cell from the primary cell inside this circuit.

(4 marks)

Hard Questions

- 1 (a) A uniform wire of length 80 cm and radius 0.50 mm is connected in series with a cell of e.m.f. 3.0 V and an internal resistance of 0.70 Ω .

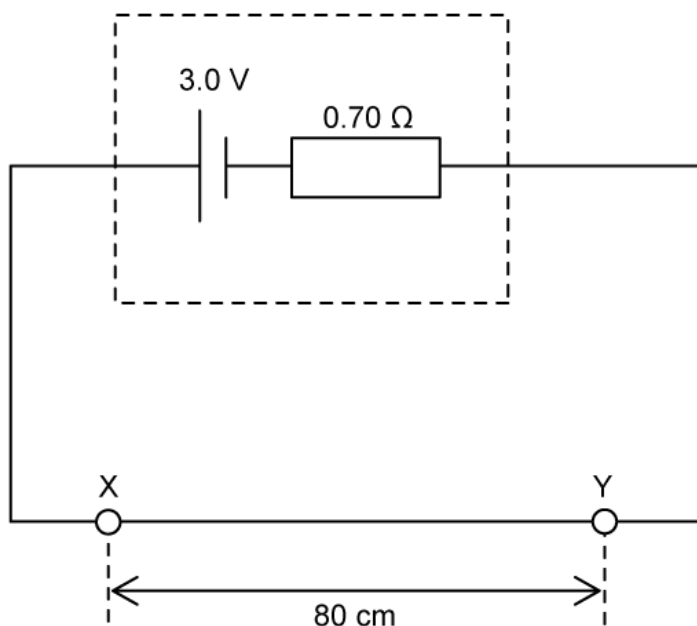

The resistivity of the metal used to make the wire is $1.10 \times 10^{-6} \Omega \text{ m}$.

Determine the current that flows in the cell.

(2 marks)

- (b) A voltmeter is connected at X, with a movable probe C, such that the voltmeter is able to read the potential difference across the wire at different points between X and Y.

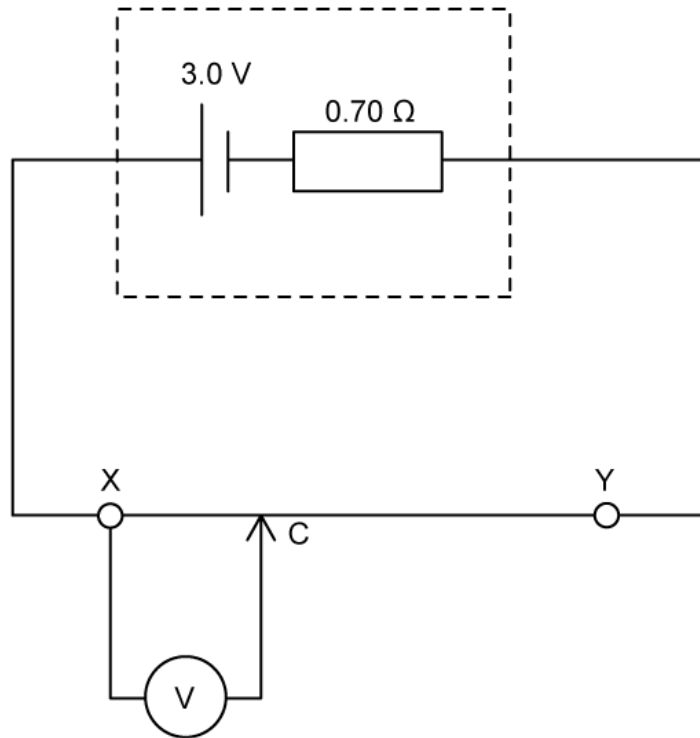

Sketch a graph on the set of axes below which shows how the potential difference V varies between X and Y as the sliding contact C moves from X to Y.

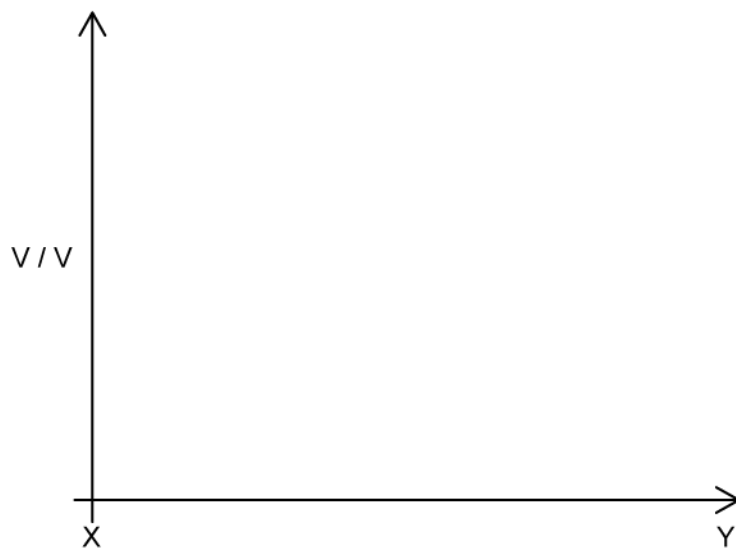

(4 marks)

- (c) The voltmeter in (b) is replaced with a cell of e.m.f. 1.5 V with internal resistance 0.50Ω , and an ammeter:

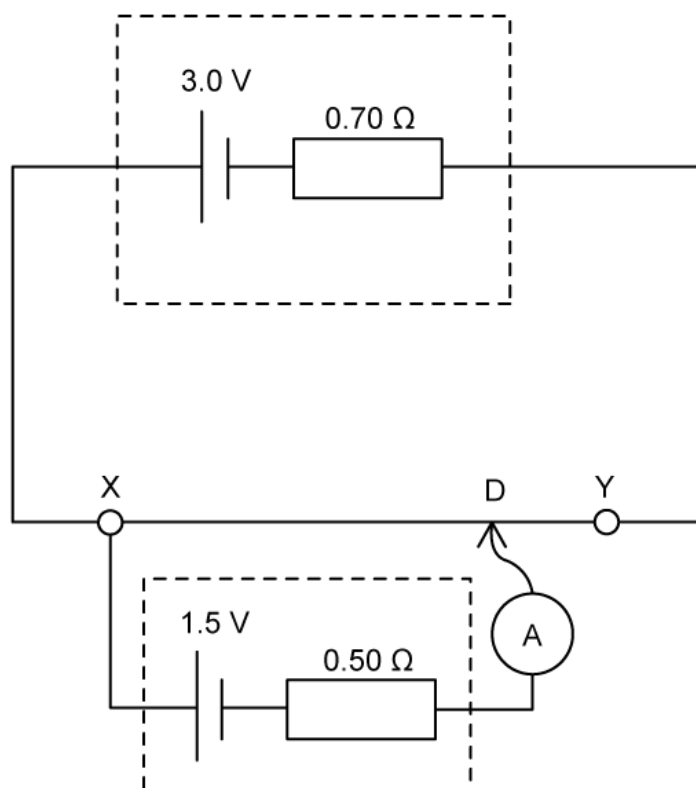

The moveable contact can again be connected to any point along the wire XY. At point D, there is zero current in the ammeter.

Calculate the length of XD.

(4 marks)

- 2 (a)** The Maximum Power Transfer theorem says the maximum amount of electrical power is dissipated in a load resistance R_L when it is exactly equal to the internal resistance of the power source r .

The circuit below is used to investigate maximum power transfer.

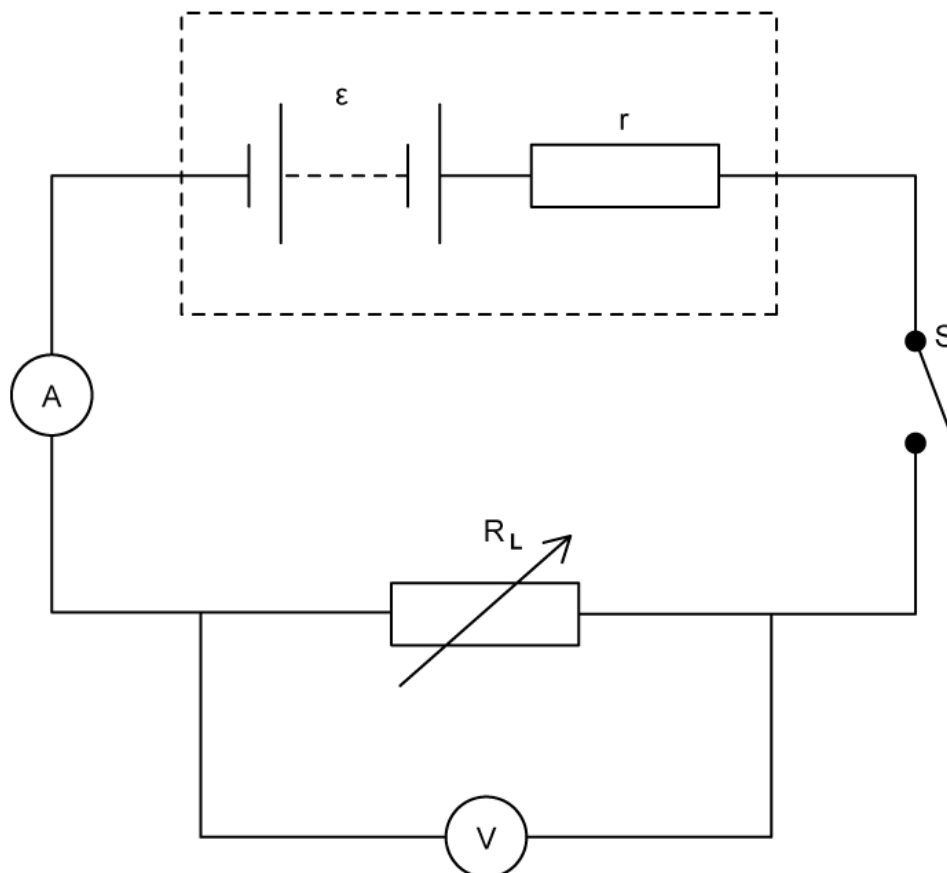

A variable resistor, which acts as the load resistance R_L , is connected to a power source of e.m.f. ϵ and internal resistance r , along with a switch S and an ammeter and voltmeter.

The graph below shows the results obtained for the power P dissipated in R_L as the potential difference V across R_L is varied:



Assuming the Maximum Power Theorem is valid, use the graph to determine the internal resistance of the power source.

.....

.....

.....

(3 marks)

(b) Show that the e.m.f. of the power supply is 9 V.

.....

.....

.....

(3 marks)

(c) Identify what happens to each of the following quantities as the value of the load resistance R_L becomes infinitely large:

- (i) Current. [1]
- (ii) Potential difference across R_L . [1]
- (iii) Power dissipated in R_L . [1]

.....

.....

.....

(3 marks)

(d) It can be shown that the power P dissipated in the load resistance R_L is zero when the load resistance is zero.

Sketch a graph on the axes provided to show how the power dissipated P varies with load resistance R_L .

Label the position of the internal resistance, r .



.....

(3 marks)

- 3 (a)** The diagram shows a circuit which can be used to investigate the internal resistance r of a power supply. In this case, a battery consisting of six dry cells in series, each of e.m.f. $\epsilon = 0.5 \text{ V}$, is connected to an oscilloscope:

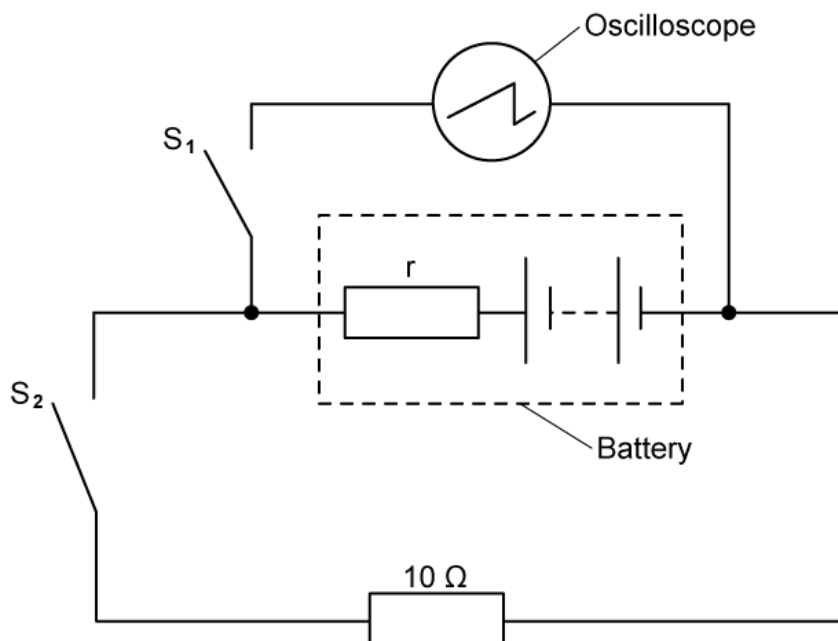

The chart below represents the trace shown on the oscilloscope screen when both of the switches S_1 and S_2 are open:

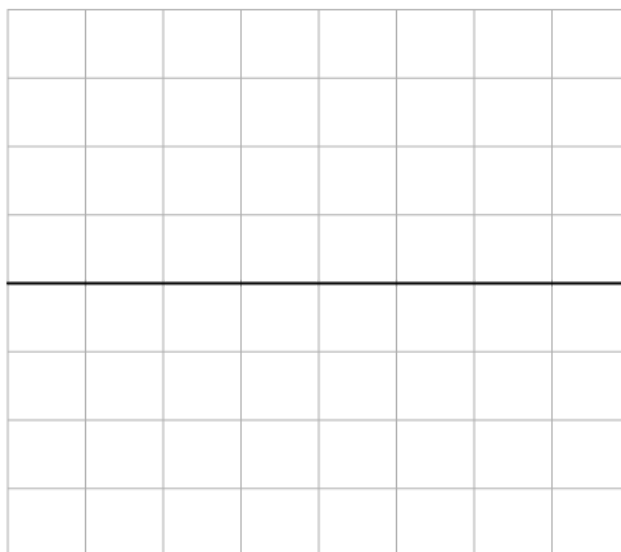

The y-gain of the oscilloscope is set at 1.5 V div^{-1} .

Discuss what happens to the trace shown on the oscilloscope screen when switch S_1 is closed.

(4 marks)

(b) Draw the trace on the oscilloscope screen when both switches S_1 and S_2 are closed. Explain your answer.

(3 marks)

(c) Calculate the internal resistance of the battery if the vertical distance between the traces in part (a) and part (b) is measured to be half a division.

(3 marks)

(d) Determine the current in the cell that would move the trace shown on the oscilloscope screen back to its original position as shown in part a. Assume both switches, S_1 and S_2 , remain closed.

(2 marks)

- 4 (a) Understanding the properties of e.m.f. and internal resistance can help the design decisions of architects and electrical engineers.

In an experiment to investigate power dissipation across two lamps, L_1 and L_2 , an engineer connects them in a series circuit to a cell of e.m.f. 45 V and internal resistance 7Ω .

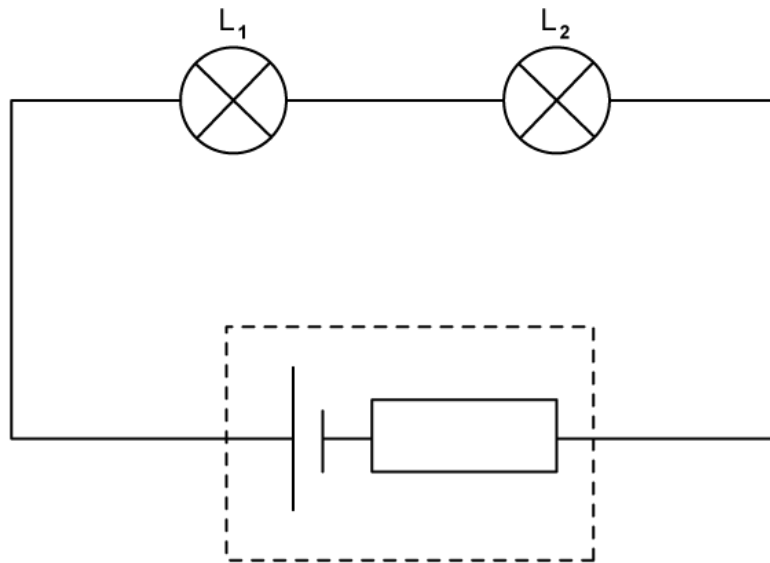

The lamp L_1 has a resistance of 10Ω and L_2 has a resistance of 25Ω .

Calculate the percentage difference between the power generated by the cell and the power dissipated in the two lamps L_1 and L_2 . Suggest a reason for this percentage difference.

.....

.....

.....

.....

.....

(5 marks)

- (b) The engineer wishes to maximise the power dissipated across each lamp and explores various alternatives to the circuit shown in part a.

Suggest and explain, using appropriate calculations, how the engineer should arrange the lamps L_1 and L_2 such that the power dissipated in each lamp is maximised.

(6 marks)

- (c) The engineer comes up with a theoretical problem, which involves arranging a large number of identical lamps in parallel with each other, as illustrated below:

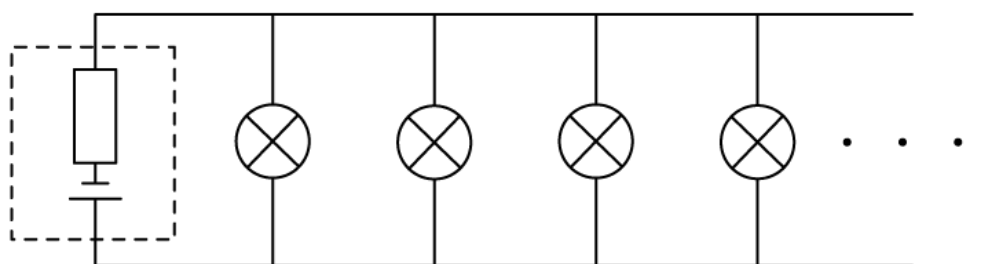

The lamps are connected to a cell of e.m.f. ϵ and internal resistance r .

Discuss the effect on the terminal p.d. supplied by the cell, and hence on the lamps, as more lamps are added in parallel.

(3 marks)