

HL IB Physics



Your notes

Wave Phenomena

Contents

- * Wavefronts & Rays
- * Reflection, Refraction & Transmission
- * Diffraction of Waves
- * Refraction of Waves
- * Superposition of Waves
- * Interference of Waves
- * Young's Double-Slit Experiment
- * Single-Slit Diffraction (HL)
- * Diffraction Gratings (HL)



Your notes

Wavefronts & Rays

Wavefronts & Rays

- Waves can travel in both two and three-dimensions:
 - A **surface wave** propagates in **two dimensions** and has **circular wavefronts** (like a circle) such as the surface of water
 - A **spherical wave** propagates in **three dimensions** and has **spherical wavefronts** (like a sphere) such as sound or light

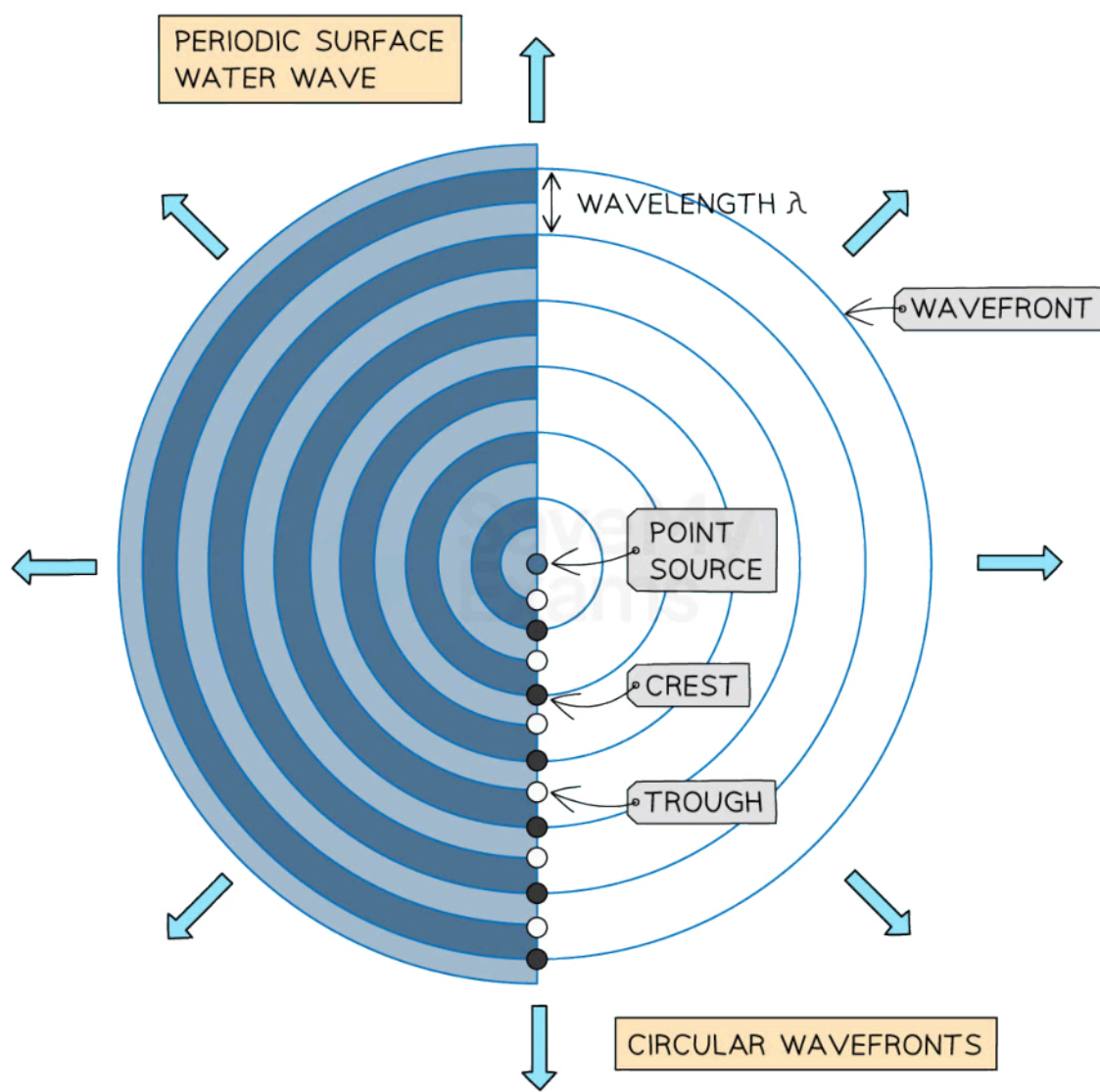

Copyright © Save My Exams. All Rights Reserved

A surface wave has circular wavefronts and moves in two-dimensions propagating outwards from the point source

Your notes

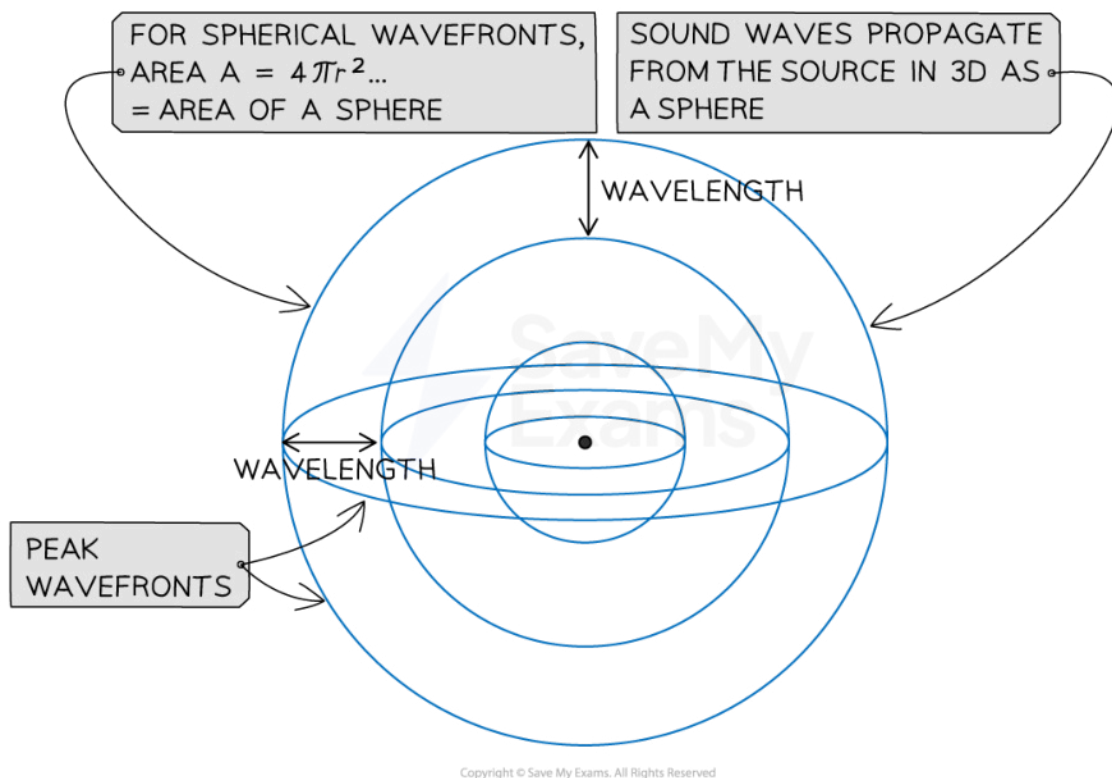

A three dimensional wave moves with spherical wavefronts in three dimensions like a sphere

- Waves can be represented graphically in two different ways:
 - **Wavefronts** - lines joining all the points that oscillate in phase and are perpendicular to the direction of motion (and energy transfer)
 - **Rays** - lines showing the direction of motion (and energy transfer) of the wave perpendicular to the wavefront



Your notes

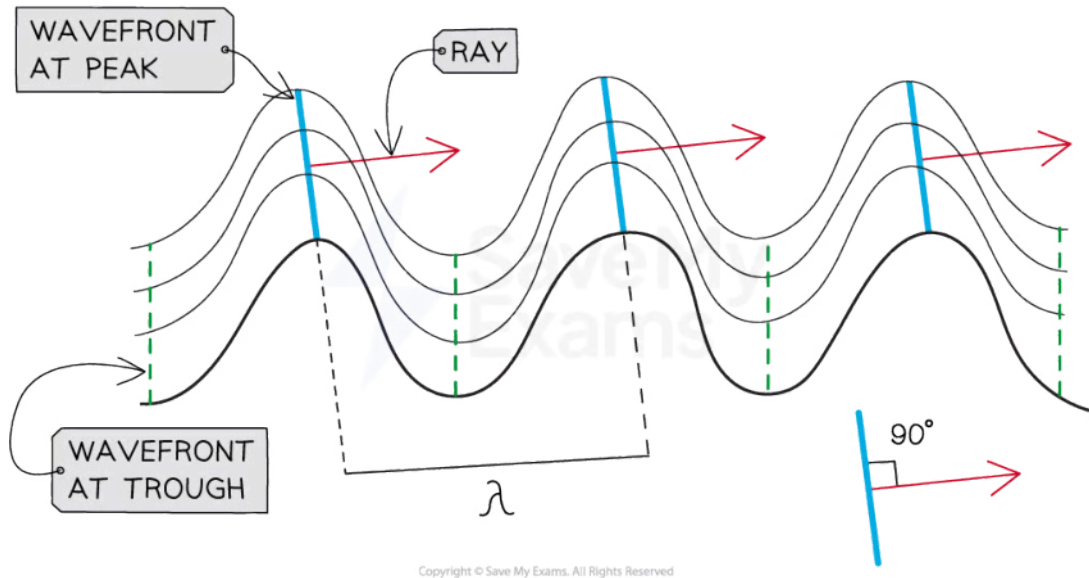

Wavefronts and rays for transverse waves travelling in a horizontal plane

- Wavefronts are viewed from above and look like a series of **parallel vertical lines**
 - Peaks are often represented with a darker line
 - Troughs are represented with a fainter line
 - Some diagrams use only peak wavefronts

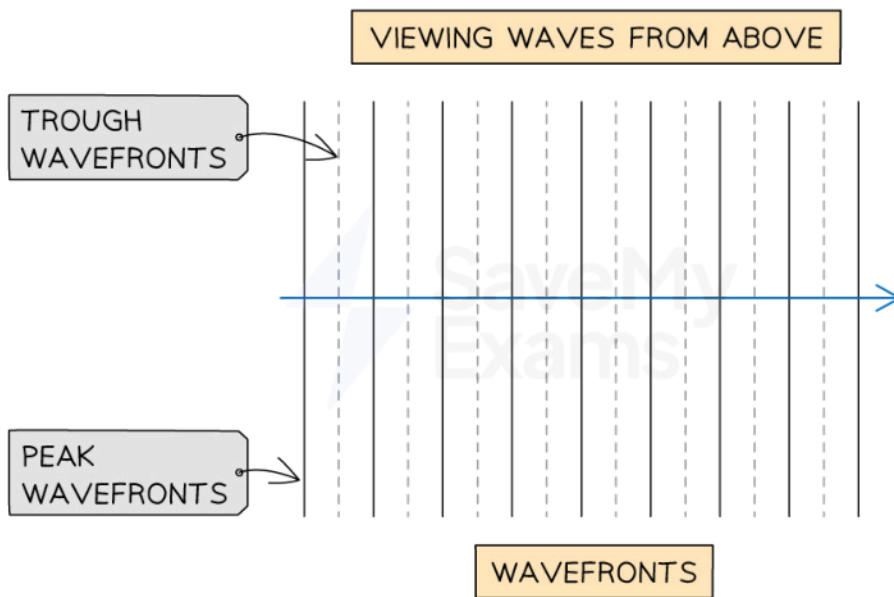

Waves can be represented using wavefronts, sometimes diagrams show peak wavefronts and trough wavefronts

- The distance between successive peak wavefronts or (trough wavefronts) is equal to the wavelength of the waves

Examiner Tip

Understanding the difference between circular and spherical wavefronts is tricky. Remember that a circle is a 2D shape, so circular wavefronts are 2D and a sphere is a 3D shape, so spherical wavefronts are 3D.

Exam questions may ask you to sketch or interpret wavefronts and rays. Make sure you draw these with a **ruler** to ensure your lines are straight. Unclear or sloping diagrams are unlikely to get full marks!



Your notes



Your notes

Reflection, Refraction & Transmission

Reflection, Refraction & Transmission

- When waves arrive at a boundary between two materials, they can be:
 - Reflected
 - Refracted
 - Transmitted
 - Absorbed
- In optics, a transparent material is called a **medium**
 - When referring to more than one medium these are called **media**

Reflection

- Reflection occurs when:

A wave hits a boundary between two media and does not pass through, but instead bounces back to the original medium

- The **law of reflection** states:

The angle of incidence, i = The angle of reflection, r

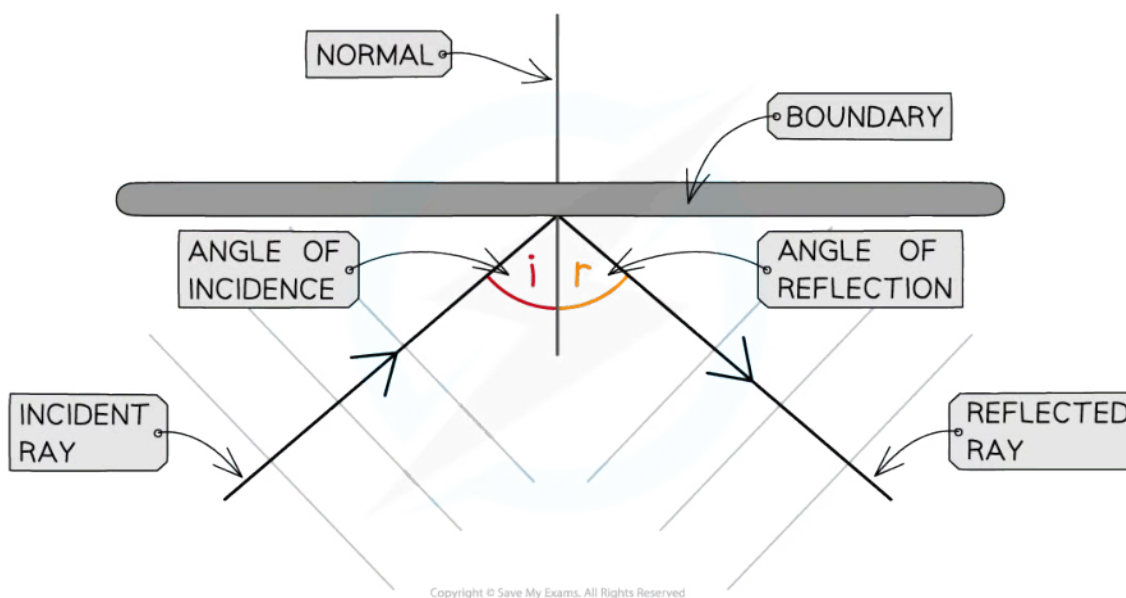

Reflection of a wave at a boundary

- When a wave is reflected, some of it may also be **absorbed** or **transmitted** through the medium
- At a boundary between two media, the **incident** ray is the ray that travels **towards** the boundary
- During reflection, the frequency, wavelength and speed of the wave does **not** change



Your notes

Refraction

- Refraction is:

The change in direction of a wave when it passes through a boundary between mediums of different density

- This change of direction is caused by a **change in the speed** of different parts of the wavefront as they hit the boundary
 - In optics, the word **medium** is used to describe a transparent material

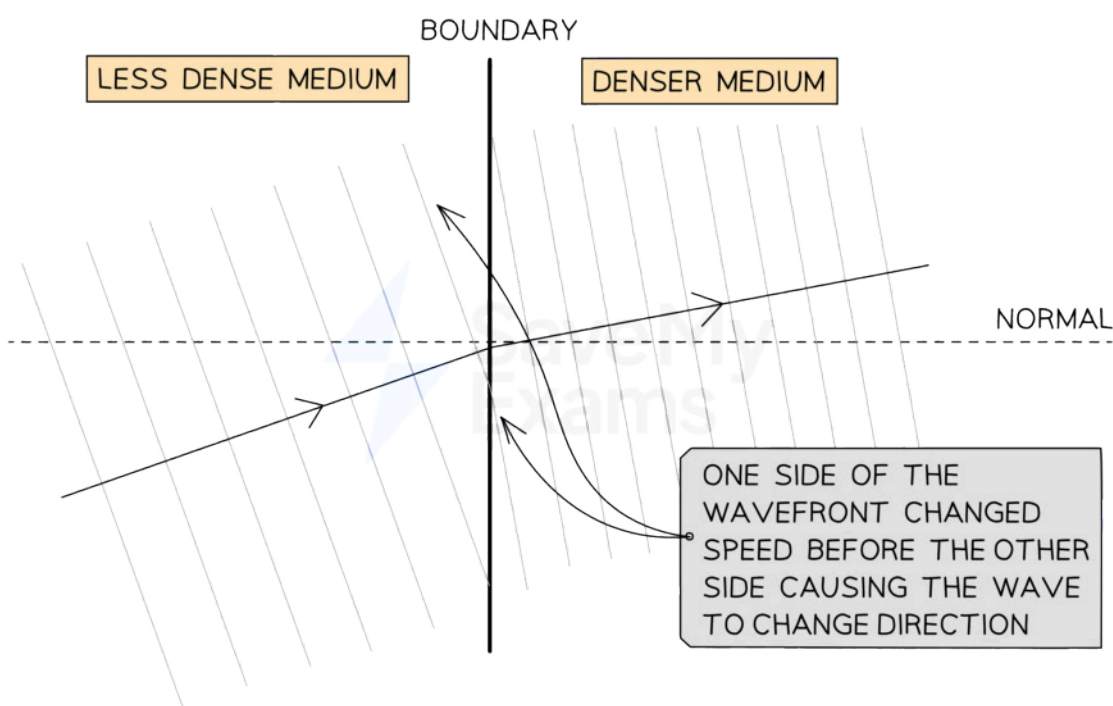

A wavefront changes direction when part of it hits a boundary and changes speed before the other parts

Conditions for refraction

- When a wave travels from a **less dense** medium into a **denser medium**:
 - The more optically **dense** the medium
 - The **slower** the waves travel
 - The **smaller** the angle of **refraction**
 - The light bends **towards** the normal
- When a wave travels from a **denser medium** into a **less dense medium**:
 - The less optically **dense** the medium
 - The **faster** the waves travel



Your notes

- The **greater** the angle of refraction
- The light bends **away** from the normal
- The amount of refraction that takes place is determined by the **difference** between the angles of **incidence** (i) and **refraction** (r) of the waves at the boundary
- The angles of incidence and refraction are measured from the **normal line**
 - This is drawn at 90° to the boundary between the two media

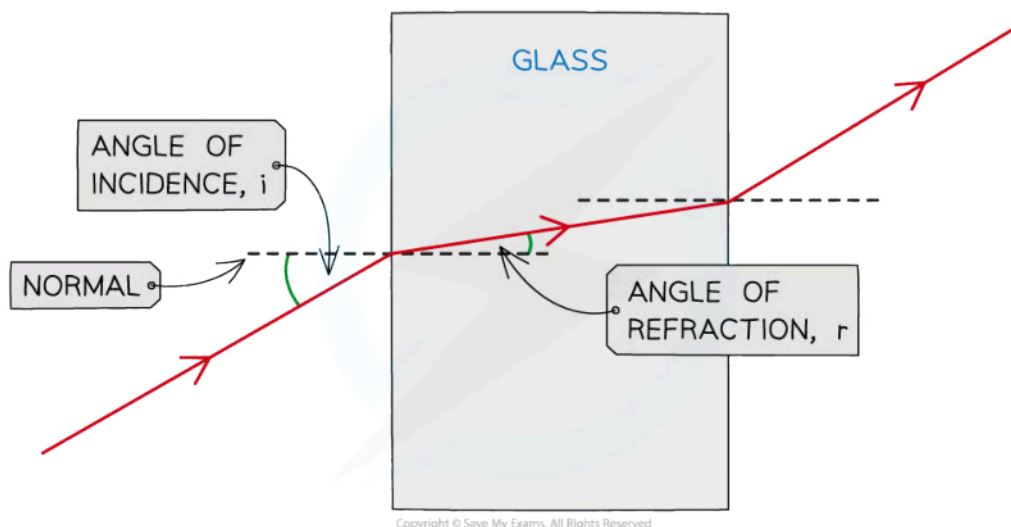

The angle of incidence is the angle between the approaching incident ray and the normal. The angle of refraction is the angle between the ray leaving the boundary and the normal.

- The amount of change in direction that takes place depends on the difference in optical **density** between the two media
- When light passes from a less dense medium to a more dense medium, (e.g. air \rightarrow glass):
 - The refracted light has a **lower speed** and a **shorter wavelength** than the incident light
- When light passes from a more dense medium to a less dense medium (e.g. glass \rightarrow air):
 - The refracted light has a **higher speed** and a **longer wavelength** than the incident light
- When a wave refracts, its speed and wavelength change, but its **frequency** remains the same
 - This is noticeable by the fact that the **colour** of the wave does **not change**



Your notes

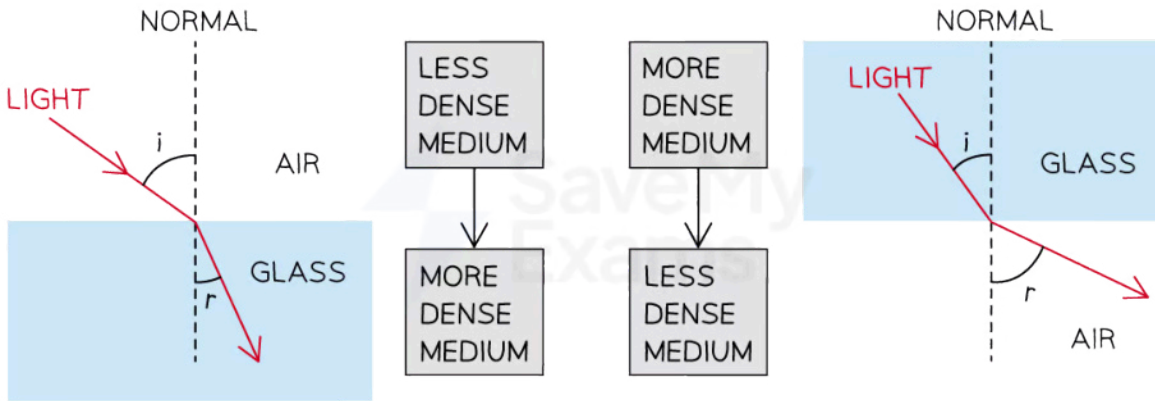

Copyright © Save My Exams. All Rights Reserved

When light passes from a less to a more dense material the ray refracts towards the normal

- When the light ray is incident on the boundary at 90° :
 - The wave passes **straight through** without a change in direction
 - This is because the whole wavefront enters the boundary at the same time at the same speed

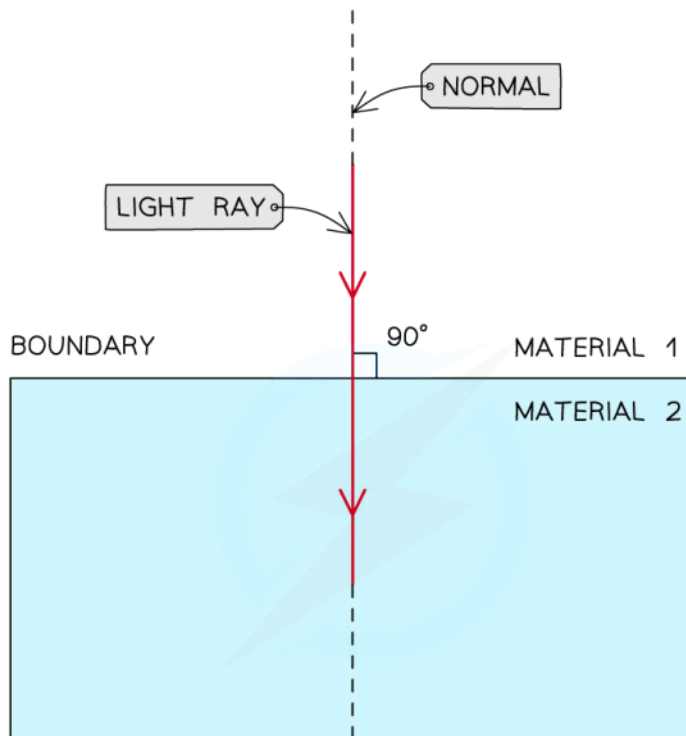

Copyright © Save My Exams. All Rights Reserved

Light travelling along the normal to the boundary between material 1 and material 2

Refraction of Water Waves

- Refraction can also occur between materials of **different depths**



Your notes

- You may be asked to explain the behaviour of water waves when they refract between deep and shallow areas
- When waves pass from **deep to shallow** water there is **more friction** between the sea bed and the wave and **less space** for the wave to oscillate so the waves:
 - **Slow down**
 - The **wavelength** of the wave **decreases**
 - So the distance between **wave peaks** is **reduced**
 - Angle of refraction is less than angle of incidence, $r < i$
- If the waves hit the boundary between the change in depth at an angle then they refract towards the normal
 - So the angle of refraction $<$ angle of incidence

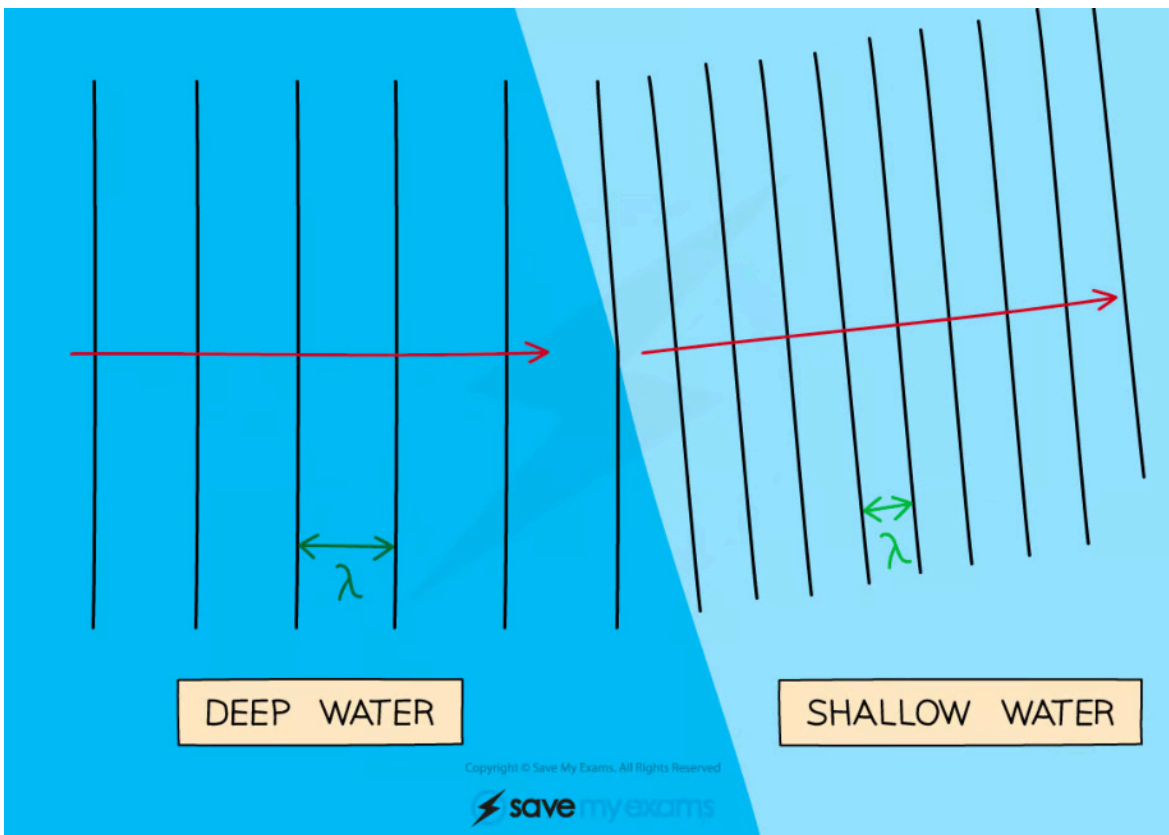

When water waves travel from deep areas to shallow areas they slow down

Transmission

- Transmission occurs when:
 - **A wave passes through a substance**
- **Refraction** is a type of transmission
 - Transmission is the more general term for a wave appearing on the opposite side of a boundary (the opposite of reflection)

- Refraction is specifically the **change in direction** of a wave when it crosses a boundary between two materials that have a different density
- When passing through a material, waves can be partially **absorbed**
- The transmitted wave will have a lower amplitude if some absorption has occurred

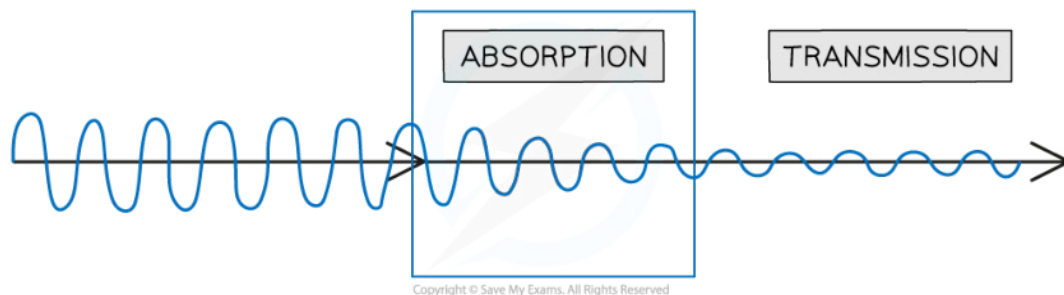

When a wave passes through a boundary it may be absorbed and transmitted

- During transmission, the frequency or speed of the wave does **not** change
- Reflection, refraction and transmission occur for **all** types of waves, both transverse and longitudinal



Your notes



Your notes

 **Examiner Tip**

You must be able to differentiate between the different types of wave behaviour. Refraction and reflection is commonly mixed up. With refraction, there is always **transmission** and a change in direction in another medium. With reflection however, there is no transmission into another medium.

It can be tricky to understand the concept of refraction. Imagine a car driving at an angle from a road and onto a patch of mud. The wheel that hits the mud will slow down first whilst the second wheel continues to travel at the initial speed. This causes the car to turn.

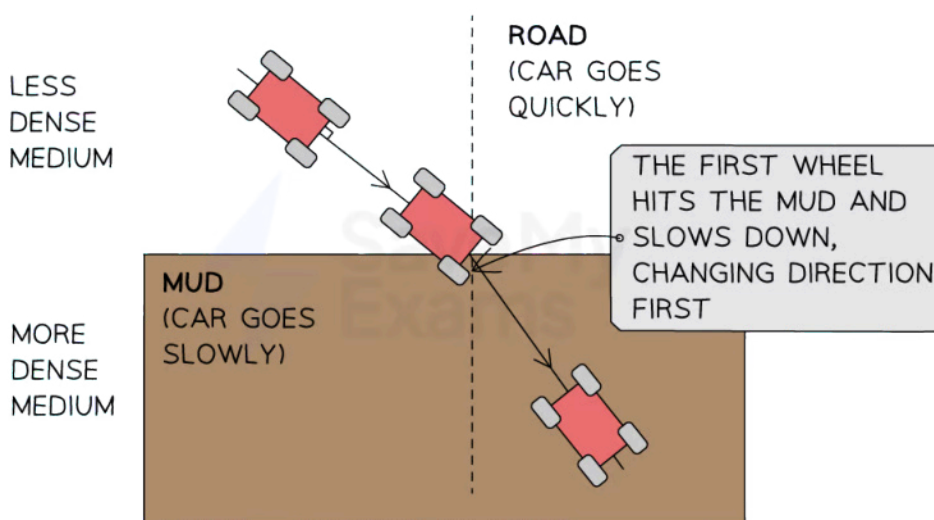

Copyright © Save My Exams. All Rights Reserved

In many situations in refraction, there are two boundaries to consider, the refracted ray from boundary 1 is the incident ray at boundary 2. Don't get confused with your notation in this situation. Label your diagram clearly to help.



Your notes

Diffraction of Waves

Diffraction of Waves

- Diffraction is defined as:
The spreading out of waves after they pass through a narrow gap or around an obstruction
- Diffraction can occur when waves:
 - pass through an **aperture**
 - pass around a **barrier**



Water waves diffract through a gap in a barrier such as in a harbour

Diffraction through an aperture

- When a wave passes through a gap or aperture:
 - The waves spread out so they have curvature
 - The amplitude of the wave is less because the barrier on either side of the gap absorbs wave energy

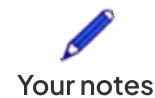
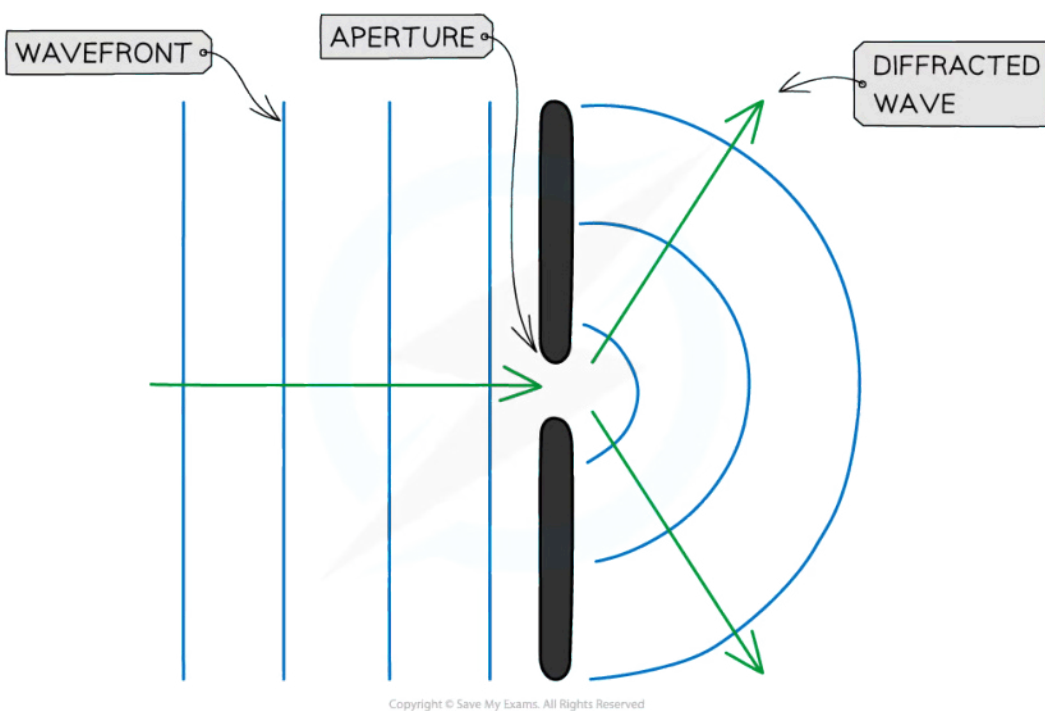

Diffraction causes waves to spread out and become curved after passing through a narrow gap

- When the **wavelength** of the wave and the **width of the gap** is similar then diffraction occurs:
 - When the wavelength is **bigger** than the gap then **more diffraction** occurs, so the wave spreads out more after passing through
 - When the wavelength is **smaller** than the gap then **less diffraction** occurs, so the wave spreads out less after passing through
- When the **wavelength** of the wave and the **width of the gap** are not similar then diffraction does not occur:
 - For gaps that are **much smaller** than the wavelength of the wave, the wave passes over the gap easily so **no diffraction** occurs
 - For gaps that are **much bigger** than the wavelength of the wave, the majority of the wave passes straight through the gap so **no diffraction** occurs
- As the **gap size increases**, compared to the **wavelength**, the amount of **curvature** on the waves gets **less pronounced**

Effect of aperture size on diffraction



Your notes

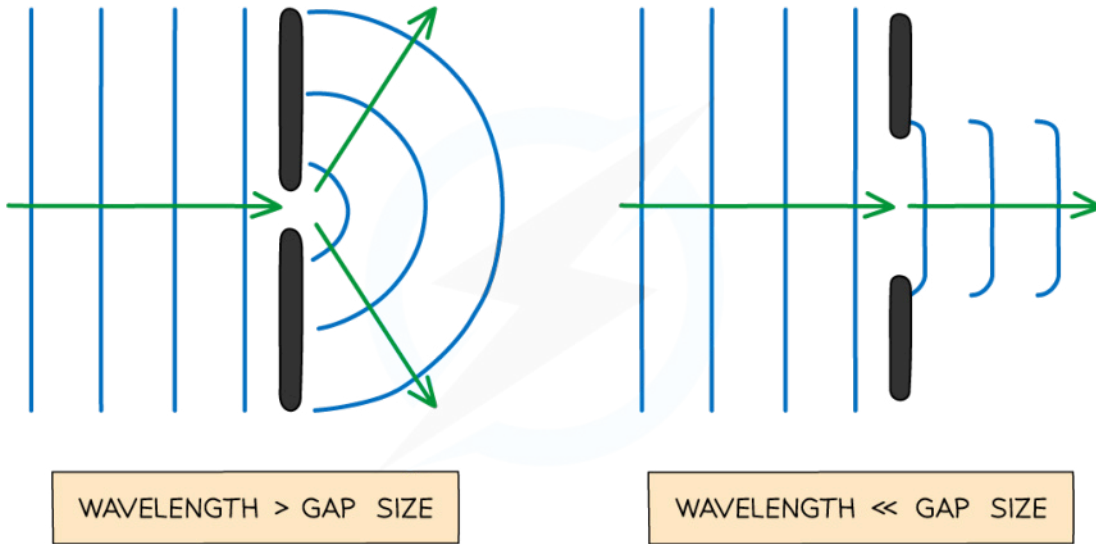

Copyright © Save My Exams. All Rights Reserved

The size of the gap (compared to the wavelength) affects how much the waves spread out when diffracted through a gap

Diffraction around a barrier

- Diffraction can also occur when waves curve around an **edge** or **barrier**
 - The waves spread out to fill the gap behind the object
- The extent of this diffraction also depends upon the wavelength of the waves
 - The **greater** the **wavelength** then the greater the **diffraction**

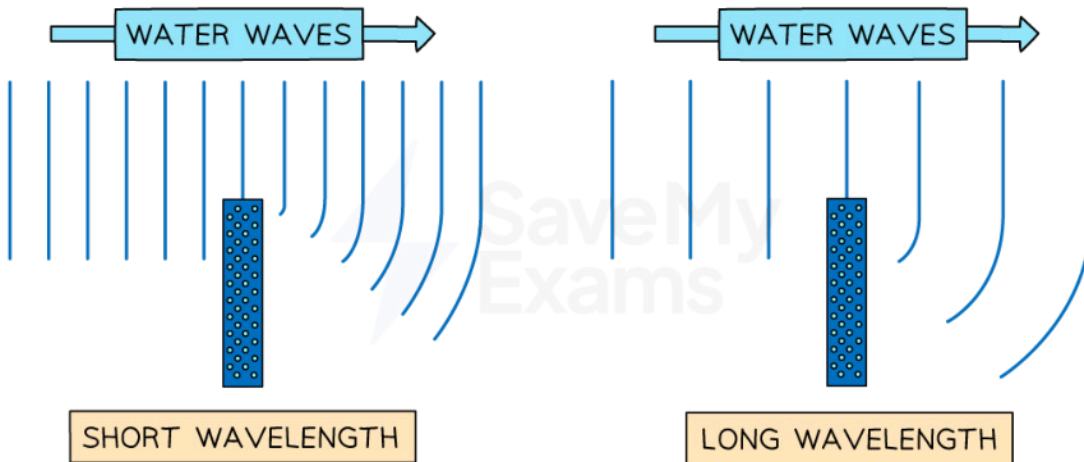

Copyright © Save My Exams. All Rights Reserved



Your notes

When a wave goes past the edge of a barrier, the waves can curve around it. Shorter wavelengths undergo less diffraction than longer wavelengths

- When the barrier is **larger** than the wavelength:
 - There is **some diffraction** around the barrier
 - A lot of incident waves are reflected back towards the source
 - There is a "**shadow**" region behind the barrier where no wavefronts are present
- When the barrier is the **same size** as the wavelength:
 - There is **more diffraction** around the barrier
 - There is a **smaller "shadow" region** behind the barrier where no wavefronts are present
- When the barrier is **smaller** than the wavelength:
 - **No diffraction** occurs around the barrier
 - The "shadow" region behind the barrier is **very small**

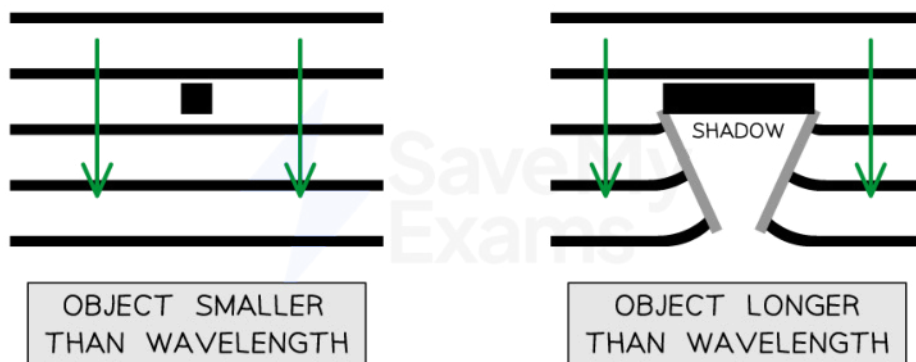

Copyright © Save My Exams. All Rights Reserved

The size of the barrier in relation to the wavelength affects how the waves diffract around it



Your notes

Worked example

When a wave is travelling through the air, which scenario best demonstrates diffraction?

- A. UV radiation through a gate post
- B. Sound waves passing a diffraction grating
- C. Radio waves passing between human hair
- D. X-rays passing through atoms in a crystalline solid

Answer: D

- Diffraction is most prominent when the wavelength is close to the aperture size

Consider option **A**:

- UV waves have a wavelength between (4×10^{-7}) and (1×10^{-8}) m so would **not** be diffracted by a gate post
- Radio waves, microwaves or sound waves would be more likely to be diffracted at this scale

Consider option **B**:

- Sound waves have a wavelength of (1.72×10^{-2}) to 17 m so would **not** be diffracted by the diffraction grating
- Infrared, light and ultraviolet waves would be more likely to be diffracted at this scale

Consider option **C**:

- Radio waves have a wavelength of 0.1 to 10^6 m so would **not** be diffracted by human hair
 - Infrared, light and ultraviolet waves would be more likely to be diffracted at this scale

Consider option **D**:

- X-rays have a wavelength of (1×10^{-8}) to (4×10^{-13}) m
 - This is a suitable estimate for the size of the gap between atoms in a crystalline solid
 - Hence X-rays could be diffracted by a crystalline solid
- Therefore, the correct answer is **D**



Your notes

Worked example

An electric guitar student is practising in his room. He has not completely shut the door of his room, and there is a gap of about 10 cm between the door and the door frame.

Determine the frequencies of sound that are best diffracted through the gap.

The speed of sound can be taken to be 340 m s^{-1}

Answer:

Step 1: Optimal diffraction happens when the wavelength of the waves is comparable to (or larger than) the size of the gap

$$\lambda = 10 \text{ cm} = 0.1 \text{ m}$$

Step 2: Write down the wave equation

$$v = f\lambda$$

- Where speed of sound, $v = 340 \text{ m s}^{-1}$

Step 3: Rearrange the above equation for the frequency f

$$f = \frac{v}{\lambda}$$

Step 4: Substitute the numbers into the above equation

$$f = \frac{340}{0.1} = 3400 \text{ Hz}$$

- The frequencies of sound that are best diffracted through the gap are:
 $f \leq 3400 \text{ Hz}$

Examiner Tip

When drawing diffracted waves, take care to keep the wavelength (the distance between each wavefront) constant.



Your notes

Refraction of Waves

Snell's Law

- **Snell's law** relates the **angle of incidence** to the **angle of refraction** at a **boundary** between two media

Refractive Index

- The refractive index, n of a material tells us how optically dense it is
- The refractive index of **air is $n = 1$**
 - Media that are **more optically dense** than air will have a refractive index of **$n > 1$**
 - Media that are **less optically dense** than air will have a refractive index of **$n < 1$**
- The higher the refractive index of a material then the more optically dense and hence the slower light will travel through it
- The refractive index of a material is calculated using the equation:

$$n = \frac{c}{v}$$

- Where:
 - n = absolute refractive index of the medium
 - c = speed of light in a vacuum in metres per second (m s^{-1}), $3.00 \times 10^8 \text{ m s}^{-1}$, as given in the data booklet
 - v = speed of light in the medium in metres per second (m s^{-1})
- Note that, being a ratio, the absolute refractive index is a **dimensionless** quantity
 - This means that it has no units

Snell's Law

- **Snell's law** is given by:

$$\frac{n_1}{n_2} = \frac{\sin \theta_2}{\sin \theta_1} = \frac{v_2}{v_1}$$

- Where:
 - n_1 = the refractive index of material 1
 - n_2 = the refractive index of material 2
 - θ_1 = the angle of incidence of the ray in material 1
 - θ_2 = the angle of refraction of the ray in material 2
 - v_1 = the speed of the wave in material 1
 - v_2 = the speed of the wave in material 2
- Snell's Law describes the angle at which light meets the boundary and the angle at which light leaves the boundary, so that the light travels through the media in the least amount of time
- Light can travel through medium 1 at a speed of v_1 due to the optical density n_1 of that medium
 - Light will approach the boundary at angle θ_1

- This is the angle of **incidence**
- Light can travel through medium 2 at a speed of v_2 due to the optical density n_2 of that medium
 - Light will leave the boundary at angle θ_2
 - This is the angle of **refraction**



Your notes

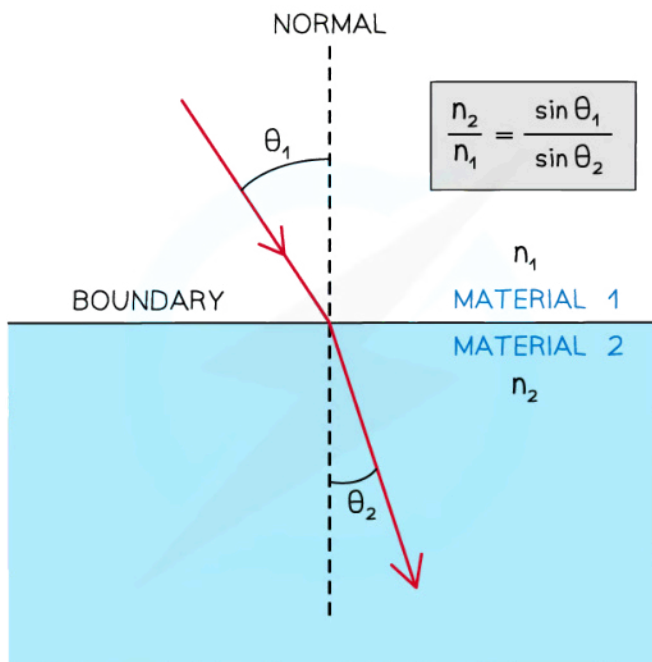

Copyright © Save My Exams. All Rights Reserved

Snell's Law

- Snell's Law can also be given in a more convenient form:

$$n_1 \sin \theta_1 = n_2 \sin \theta_2$$



Your notes

 **Worked example**

Wavefronts travel from air to water as shown. Add the refracted wavefronts to the diagram.

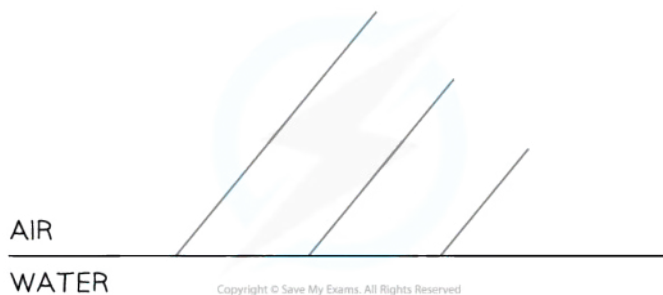

Answer:

Step 1: Add the incident ray to mark the direction of the incident waves

- The incident ray must be perpendicular to all wavefronts
- Remember to add an arrow pointing towards the air-water boundary

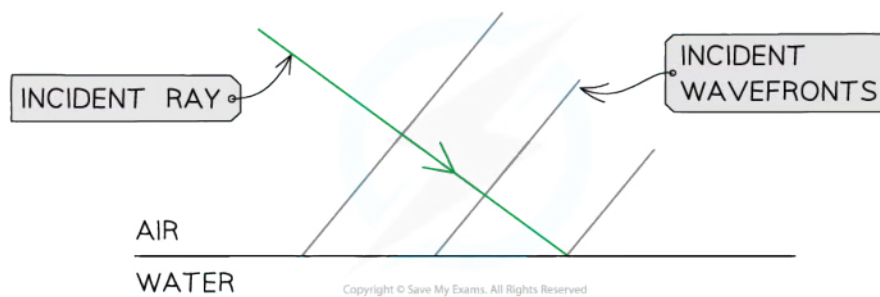

Step 2: Add the normal at the point of incidence

- Mark the angle of incidence (i) between the normal and the incident ray



Your notes

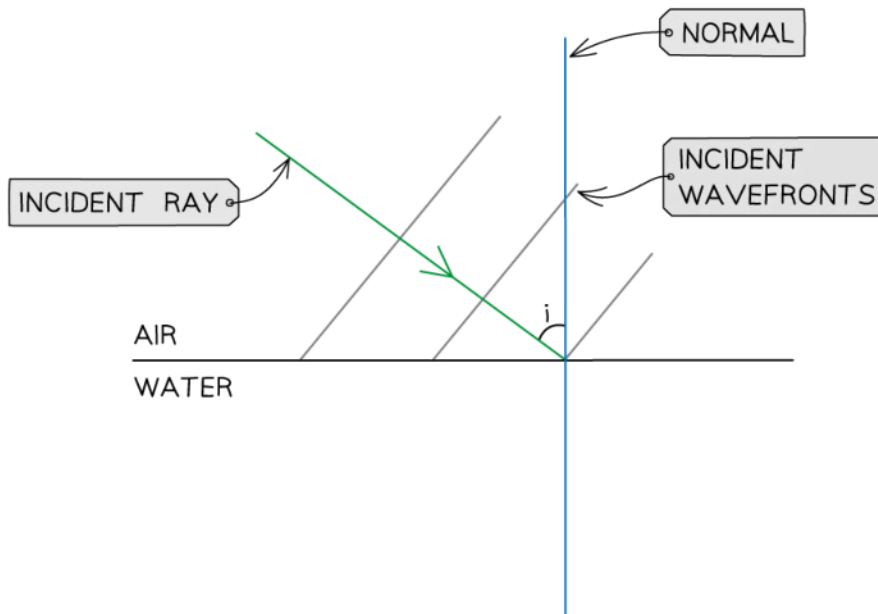

Step 3: Draw the refracted ray into the water

- Water is optically denser than air
- The refracted ray must bend towards the normal
- Mark the angle of refraction (r) between the normal and the refracted ray
- By eye, $i > r$

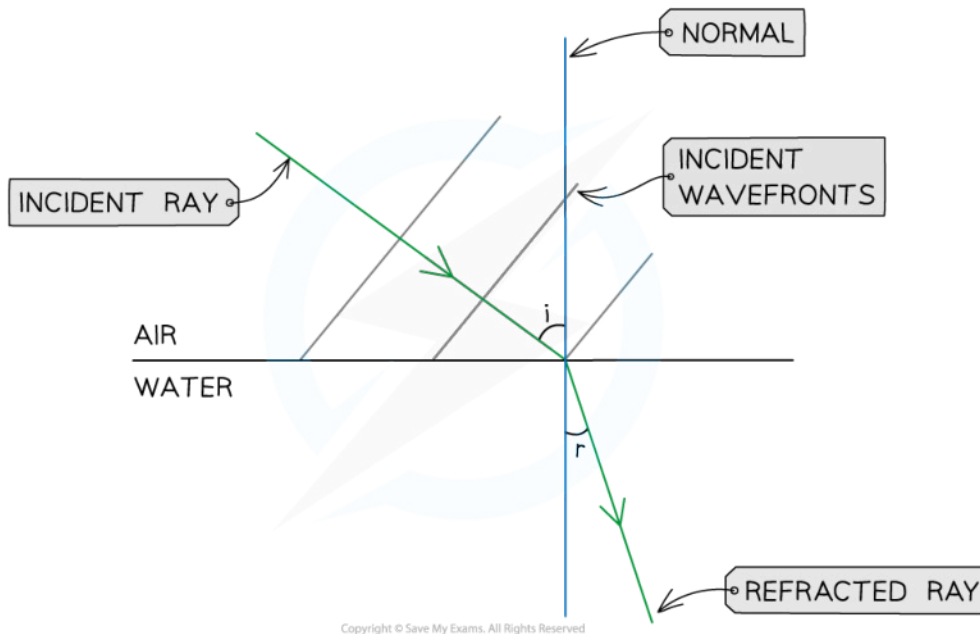

Copyright © Save My Exams. All Rights Reserved



Your notes

Step 4: Add three equally spaced wavefronts, all perpendicular to the refracted ray

- The refracted wavefronts must be closer to each other than the incident wavefronts, since:
 - The speed v of the waves decreases in water
 - The frequency f of the waves stays the same
 - The wavelength λ of the waves in water is shorter than the wavelength of the waves in air $\lambda_w < \lambda_A$, since $v = f\lambda$

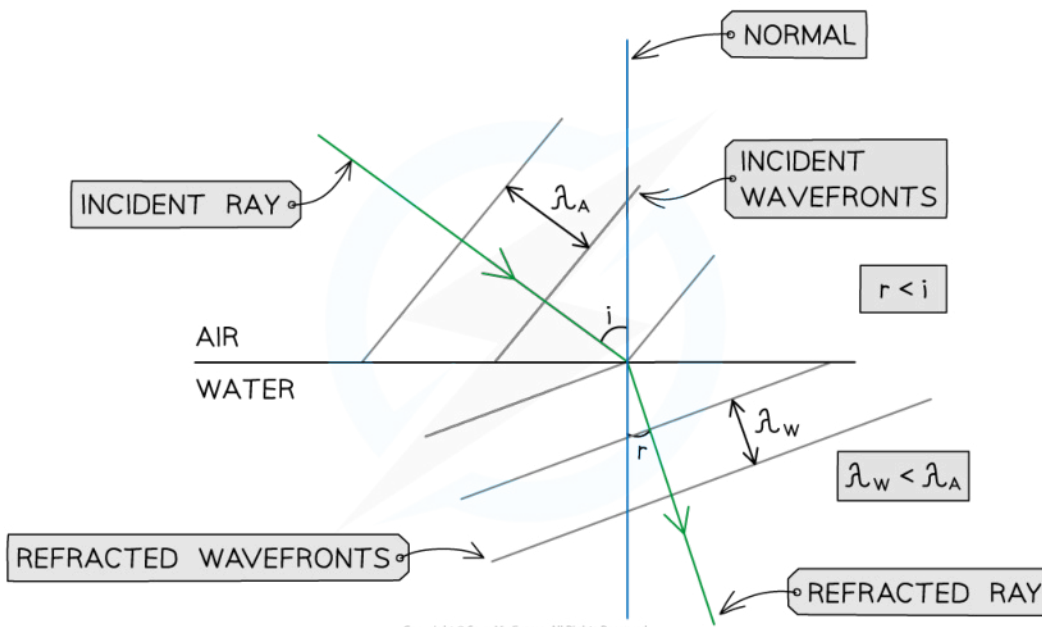



Your notes

Worked example

Light travels from air into glass. Determine the speed of light in glass.

- Refractive index of air, $n_1 = 1.00$
- Refractive index of glass, $n_2 = 1.50$

Answer:

Step 1: Write down the known quantities

- $n_1 = 1.00$
- $n_2 = 1.50$
- From the data booklet, $c = 3 \times 10^8 \text{ m s}^{-1}$ (speed of light in air)

Step 2: Write down the relationship between the refractive indices of air and glass and the speeds of light in air (v_1) and glass (v_2)

$$\frac{n_1}{n_2} = \frac{v_2}{v_1}$$

Step 3: Rearrange the above equation to calculate v_2

$$v_2 = \frac{n_1}{n_2} v_1$$

Step 4: Substitute the numbers into the above equation

$$v_2 = \frac{1.00}{1.50} \times (3 \times 10^8)$$

$$v_2 = 2 \times 10^8 \text{ m s}^{-1}$$



Your notes

Worked example

A light ray is directed at a vertical face of a glass cube. The angle of incidence at the vertical face is 39° and the angle of refraction is 25° as shown in the diagram.

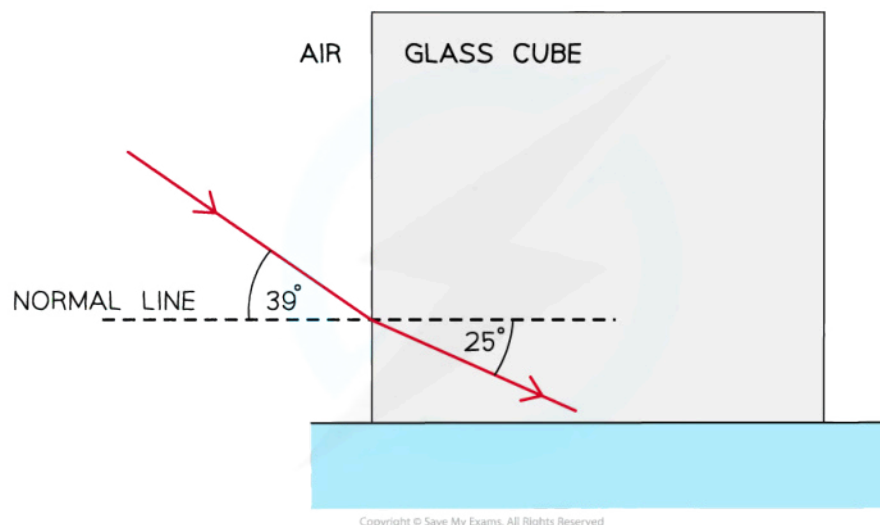

Show that the refractive index of the glass is about 1.5.

Answer:

Step 1: Write down the known quantities

- Refractive index of air, $n_1 = 1$
- Refractive index of glass = n_2
- Angle of incidence, $\theta_1 = 39^\circ$
- Angle of refraction, $\theta_2 = 25^\circ$

Step 2: Write out Snell's Law

$$\frac{n_2}{n_1} = \frac{\sin \theta_1}{\sin \theta_2}$$

Step 3: Calculate the refractive index of glass

$$n_2 = \frac{\sin 39}{\sin 25} = 1.489 = 1.5 \text{ (2 s.f.)}$$

- Note that in a "show that" question, the answer should be to at least one more significant figure than the value given in the question

 **Examiner Tip**

Always double-check if your calculations for the refractive index are greater than 1. Otherwise, something has definitely gone wrong in your calculation! The refractive index of air might not be given in the question. Always assume that $n_{\text{air}} = 1$

Make sure your calculator is always in **degrees** mode for calculating the sine of angles!

Always check that the angle of incidence and refraction are the angles between the normal and the light ray. If the angle between the light ray and the boundary is calculated instead, calculate $90 - \theta$ (since the normal is perpendicular to the boundary) to get the correct angle



Your notes



Your notes

Critical Angle & Total Internal Reflection (TIR)

- As the angle of incidence (i) is increased, the angle of refraction (r) also increases until it gets closer to 90°
- When the angle of refraction is exactly 90° the light is refracted along the boundary between the two material
 - At this point, the angle of incidence is known as the **critical angle** θ_c

Critical Angle

- The larger the refractive index of a material, the smaller the critical angle
- When light is shone at a **boundary** between two materials, different angles of incidence result in different angles of refraction
 - As the angle of incidence is increased, the angle of refraction also increases
 - Until the **angle of incidence** reaches the **critical angle**
- When the **angle of incidence = critical angle** then:
 - Angle of refraction = 90°
 - The refracted ray is refracted **along the boundary** between the two materials
- When the **angle of incidence < critical angle** then:
 - the ray is refracted and exits the material
- When the **angle of incidence > critical angle** then:
 - the ray undergoes **total internal reflection**

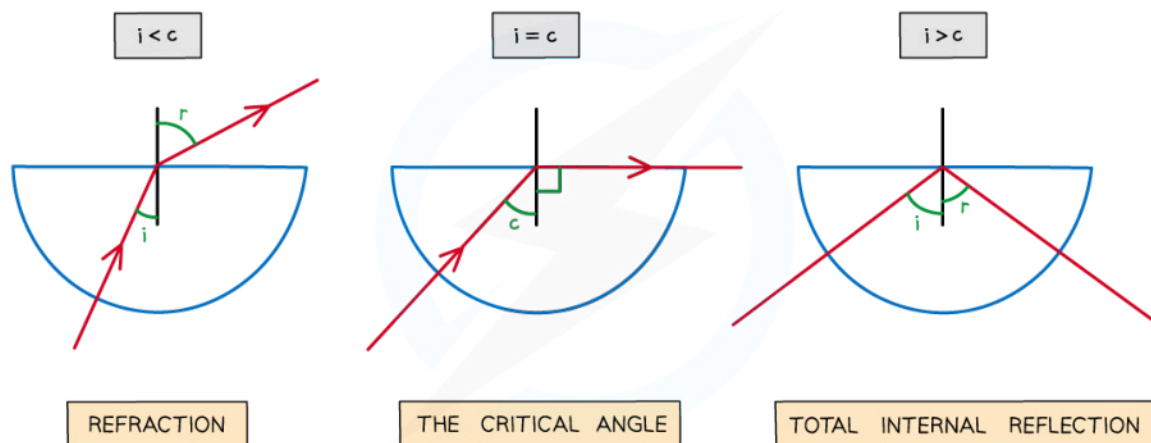

Copyright © Save My Exams. All Rights Reserved

As the angle of incidence increases it will eventually exceed the critical angle and lead to the total internal reflection of the light



Your notes

Critical Angle Equation

- The critical angle of material 1 is found using the equation:

$$\sin \theta_c = \frac{n_2}{n_1}$$

- Where:
 - θ_c = critical angle of material 1 (°)
 - n_1 = absolute refractive index of material 1
 - n_2 = absolute refractive index of material 2
- The **two conditions** for total internal reflection to occur are:
 - The refractive index of the **second** medium must be **less** than the refractive index of the first, $n_2 < n_1$
 - The angle of **incidence** must be **greater** than the **critical** angle, $\theta_i > \theta_c$

Total Internal Reflection

- Total internal reflection is a special case of refraction that occurs when:
 - The **angle of incidence** within the denser medium is **greater** than the **critical angle** ($i > \theta_c$)
 - The incident refractive index n_1 is **greater** than the refractive index of the material at the boundary n_2 ($n_1 > n_2$)
- Total internal reflection follows the law of reflection

angle of incidence = angle of reflection

- A **denser medium** has a **higher refractive index**
 - For example, the refractive index of glass, $n_g >$ the refractive index of air, n_a
- Light rays inside a material with a **higher refractive index** are more likely to be **totally internally reflected**



Your notes

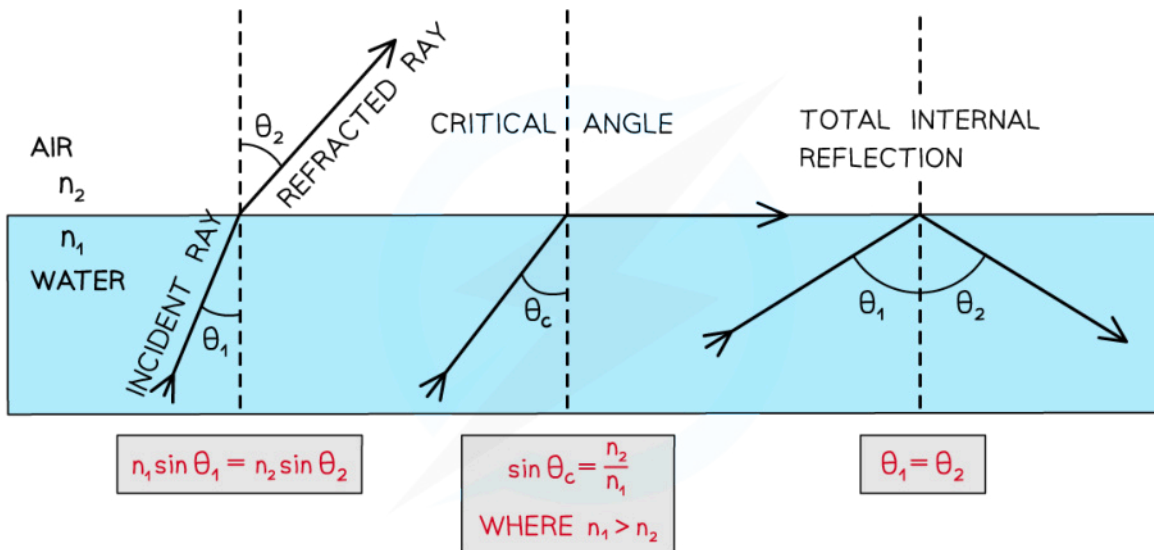

Angles of incidence, reflection and refraction to satisfy the conditions for total internal reflection



Your notes

Worked example

Light travels from a material with refractive index 1.2 into air.

Determine the critical angle of the material.

Answer:

Step 1: Write down the known quantities

- Refractive index of material 1, $n_1 = 1.2$
- Refractive index of air, $n_2 = 1.0$

Step 2: Write down the equation for the critical angle θ_c

$$\sin\theta_c = \frac{n_2}{n_1}$$

Step 3: Substitute the numbers into the above equation

$$\sin\theta_c = \frac{1.0}{1.2}$$

$$\sin\theta_c = 0.83$$

Step 4: Calculate θ_c by taking \sin^{-1} of the above equation

$$\theta_c = \sin^{-1} 0.83$$

$$\theta_c = 56^\circ$$

Examiner Tip

You do not need to remember the derivation for the critical angle, but you must understand and remember the critical angle formula, as this is **not** given in your data booklet.



Your notes

Superposition of Waves

Superposition of Waves

- When two or more waves arrive at the same point and overlap, their amplitudes combine
 - This is called **superposition**
- The **principle of superposition** states that:

When two or more waves overlap at a point, the displacement at that point is equal to the sum of the displacements of the individual waves

- The superposition of **surface water waves** shows the effect of this overlap
 - There are areas of zero displacement, where the water is flat
 - There are areas of increased displacement, where the water waves are higher

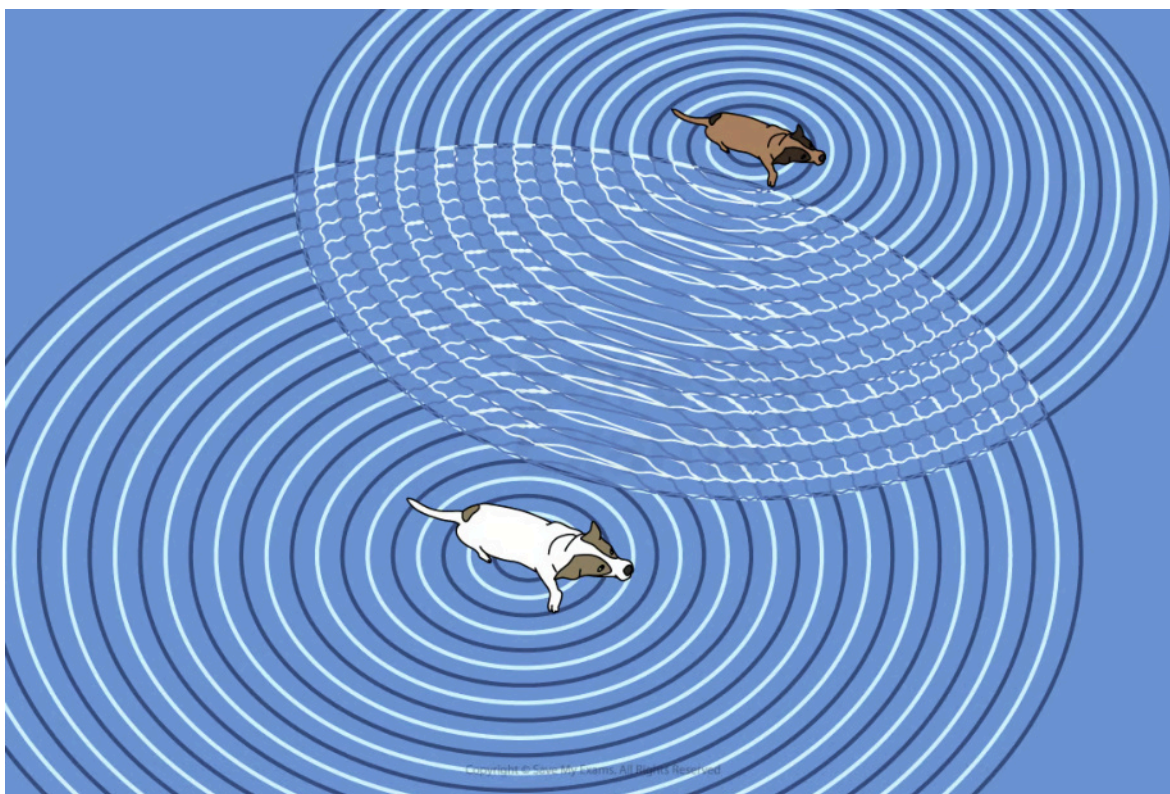

The dogs make waves in the water which superimpose to give areas of both zero and increased displacement.

- It is possible to analyse superposition clearly when the waves are drawn on a vertical displacement (amplitude)-displacement graph



Your notes

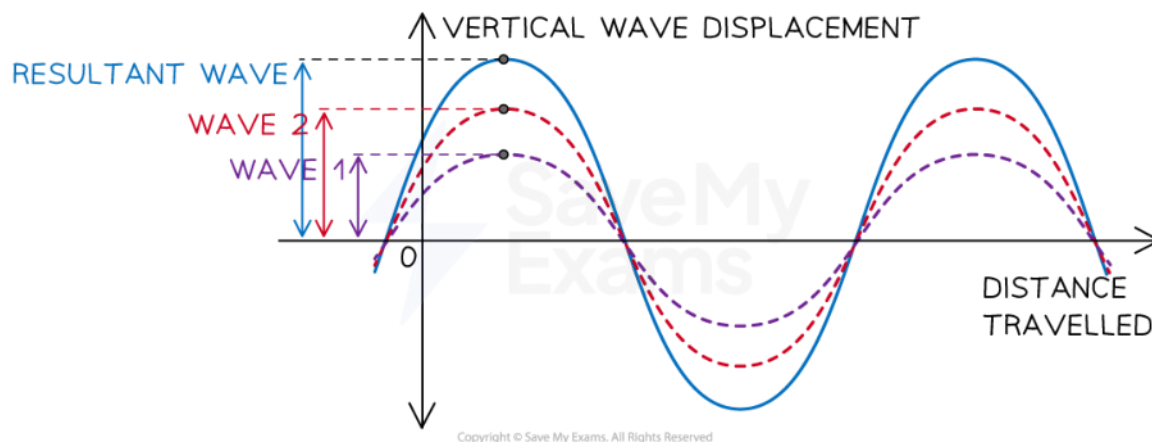

Waves can superimpose so their amplitudes are added together often creating a larger resultant amplitude

- **Interference** is the effect of this overlap
 - This is explained in the next [Interference of Waves](#)
- Individual wave displacements may be positive or negative and are **combined** in the same way as other **vector** quantities
- It is possible to analyse superposition clearly when the waves are drawn on a displacement-time graph
- Superposition can also be demonstrated with **two pulses**
 - When the pulses meet, the resultant displacement is also the **algebraic sum** of the displacement of the individual pulses
 - After the pulses have interacted, they then carry on as normal



Your notes

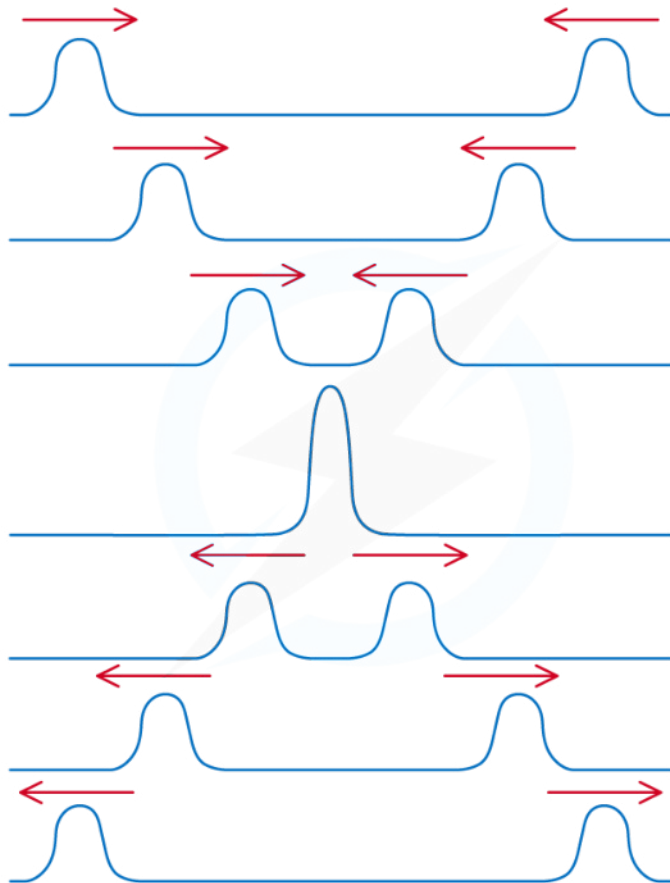

Copyright © Save My Exams. All Rights Reserved

When two pulses overlap their displacements combine to form a resultant displacement



Your notes

 **Worked example**

Two overlapping waves of the same type travel in the same direction. The variation with x and y displacement of the wave is shown in the figure below.

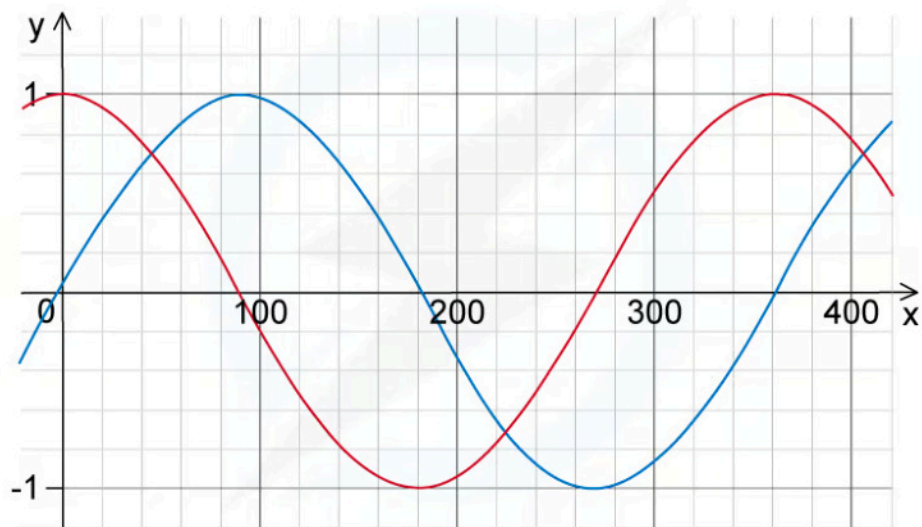

Use the principle of superposition to sketch the resultant wave.

Answer:



Your notes

THE GRAPH OF THE SUPERPOSITION OF BOTH WAVES IS SHOWN IN BLACK BELOW:

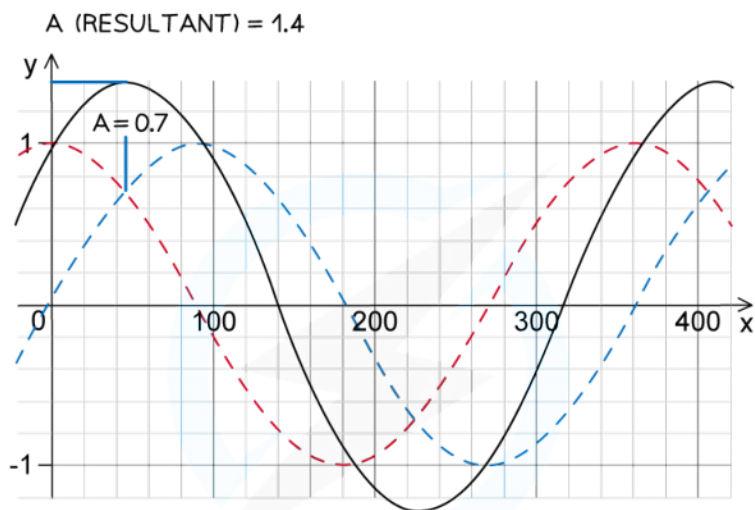

TO PLOT THE CORRECT AMPLITUDE AT EACH POINT, SUM THE AMPLITUDE OF BOTH GRAPHS AT THAT POINT.

e.g. AT POINT A – EACH GRAPH HAS A VALUE OF 0.7. THEREFORE THE SAME POINT WITH THE RESULTANT SUPERPOSITION IS $0.7 \times 2 = 1.4$

Copyright © Save My Exams. All Rights Reserved



Your notes

Interference of Waves

Double Source Interference

- Double-source interference involves producing a **diffraction** and an **interference pattern** using either:
 - The interference of two **coherent** wave sources
 - A single wave source passing through a **double slit**
- Examples of double-source interference include:
 - A **laser beam** that creates bright and dark fringes on a screen
 - Two speakers** emitting a coherent sound
 - Microwaves** diffracted through two slits

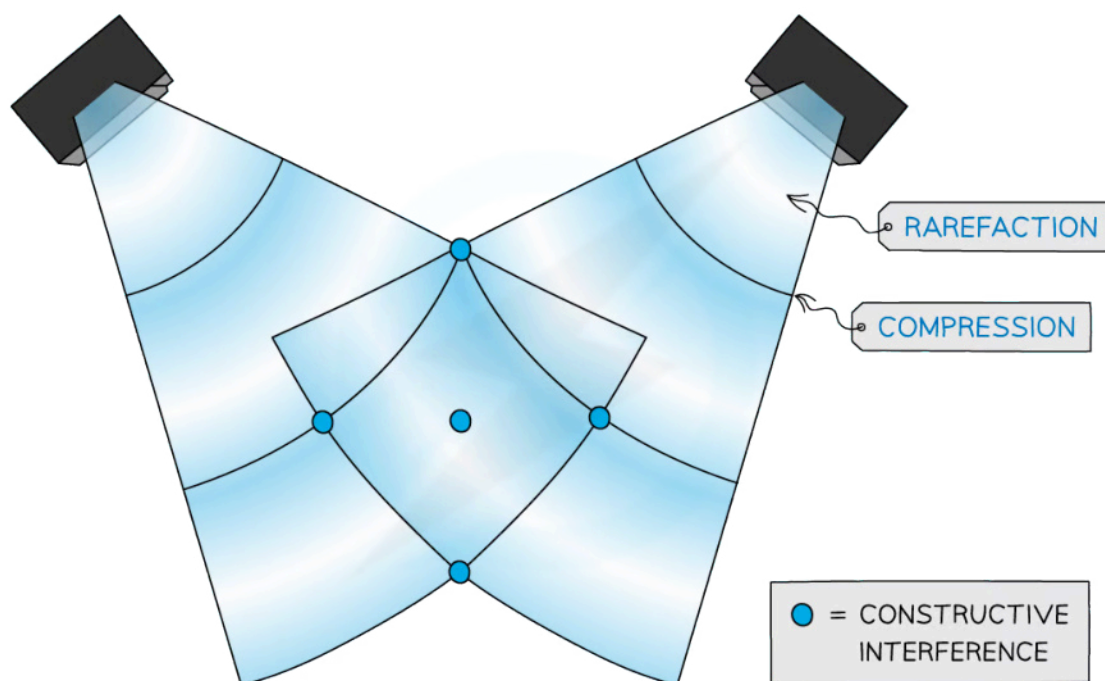

Copyright © Save My Exams. All Rights Reserved

Sound wave interference from two speakers emitting a coherent sound



Your notes

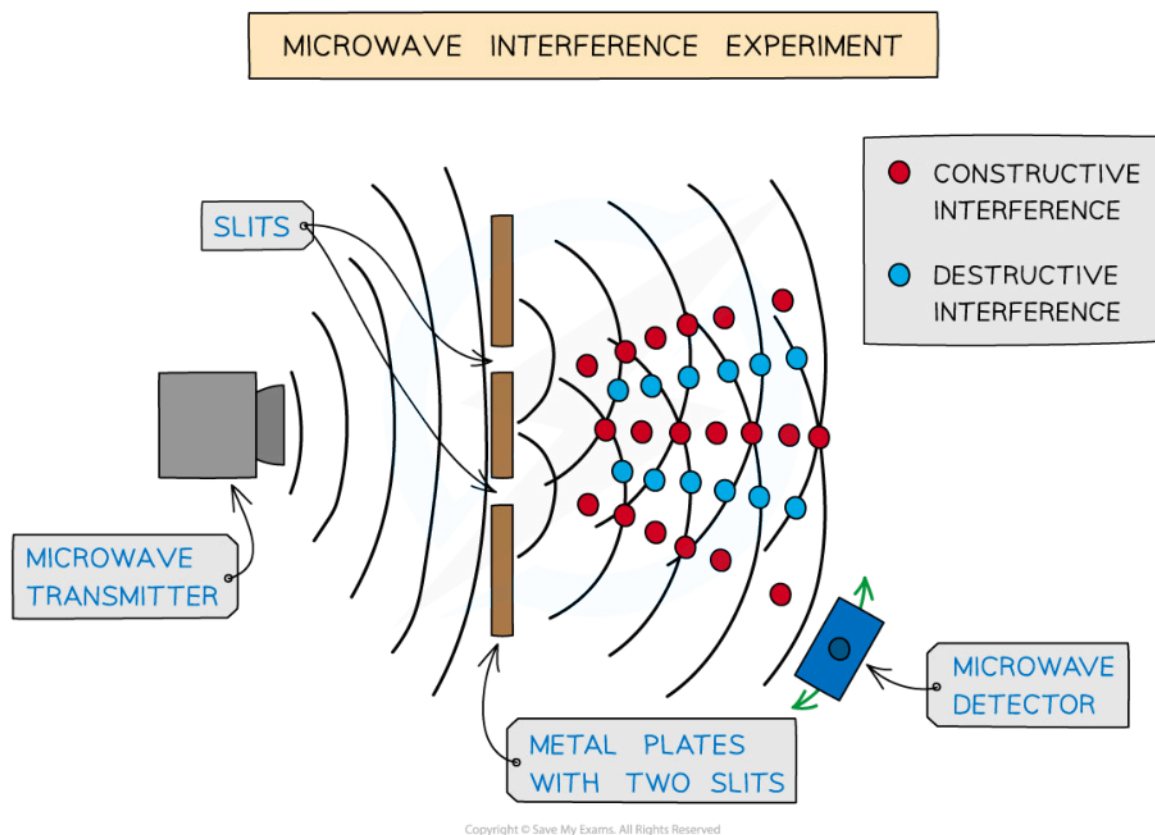

A microwave interference experiment creates a diffraction pattern with regions where microwaves are and are not detected

Interference

- Interference is the effect observed due to the **superposition** of two or more waves
 - It can be seen clearly when waves overlap completely in **phase** or **antiphase**
- The **maximum** amount of superposition occurs when two waves are in **phase**
 - They meet either **peak-to-peak** or **trough-to-trough**
 - This results in the two waves **adding together**
 - This is called **constructive interference**
- The **minimum** amount of superposition occurs when two waves are in **antiphase**
 - They meet **peak-to-trough**
 - This results in the two waves **cancelling** each other out and having zero effect (there is an effect - that they cancel out)
 - This is called **destructive interference**
- Constructive and destructive interference occurs when waves are **coherent**



Your notes

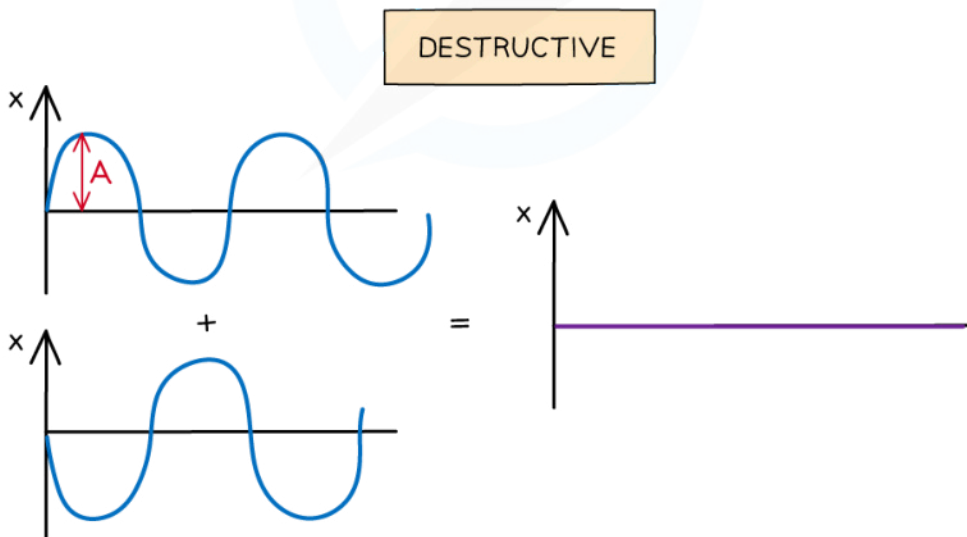
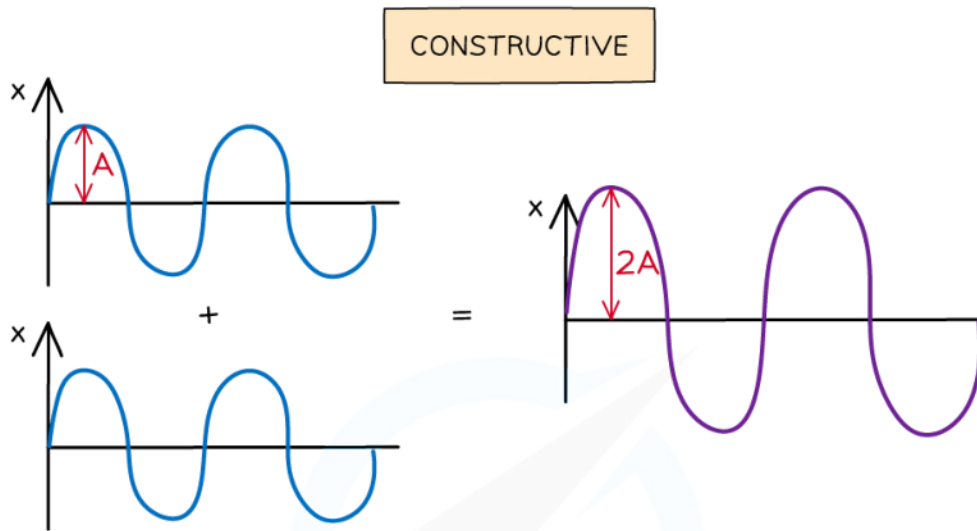

Copyright © Save My Exams. All Rights Reserved

Waves undergo the maximum amount of constructive and destructive interference when they are in phase or antiphase

Coherence

- For waves to be coherent they must have:
 - The same **frequency**
 - A **constant phase difference**



Your notes

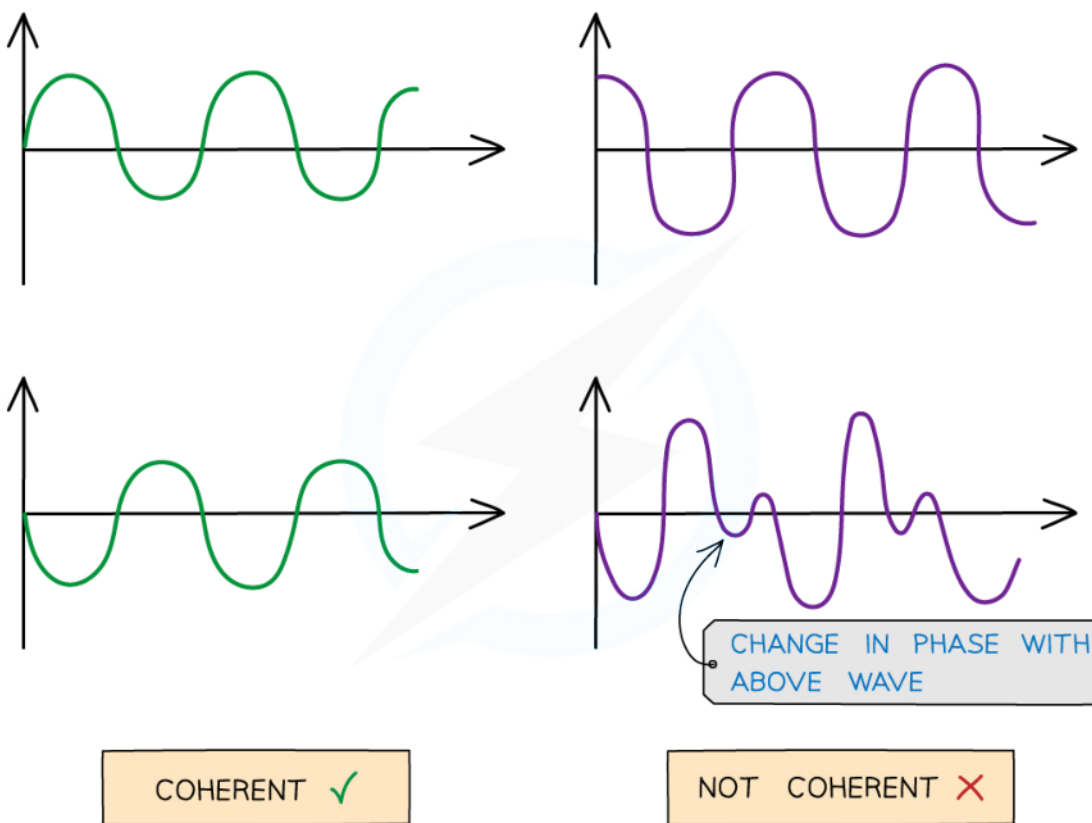

Copyright © Save My Exams. All Rights Reserved

Coherent vs. non-coherent waves. The abrupt change in phase creates an inconsistent phase difference.

- At points where two waves are neither in **phase** nor in **antiphase**, the resultant amplitude is somewhere in between the two extremes
- Examples of interference from coherent light sources are:
 - Monochromatic **laser** light
 - Sound waves from two nearby **speakers** emitting sound of the same frequency



Your notes

Constructive & Destructive Interference

- Whether waves are in phase or antiphase is determined by their **path difference**

Path Difference

- Path difference is defined as:

The difference in distance travelled by two waves from their sources to the point where they meet

- Path difference vs phase difference
 - Phase difference** compares the **distance** between the **phases** (peaks and troughs) of waves that are normally travelling parallel to each other at a point
 - Path difference** compares the amount of **progress** made by waves along a **path**, so the difference in the distance travelled by the two waves

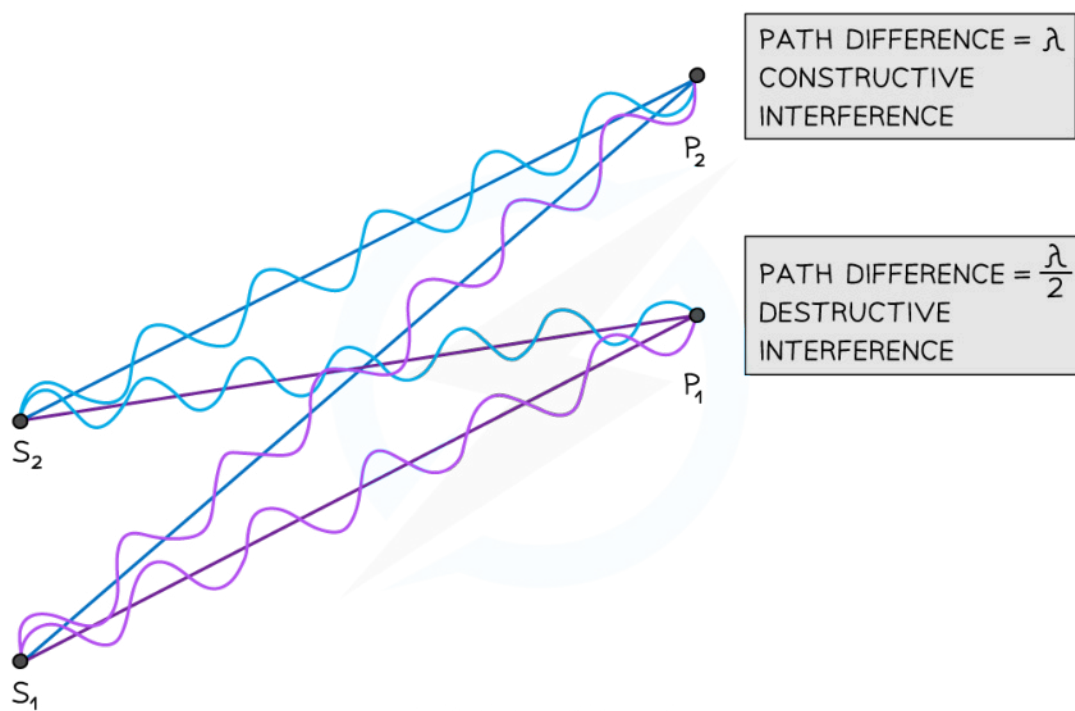

PATH DIFFERENCE = λ
CONSTRUCTIVE INTERFERENCE

PATH DIFFERENCE = $\frac{\lambda}{2}$
DESTRUCTIVE INTERFERENCE

At point P_2 the waves have a path difference of a whole number of wavelengths resulting in constructive interference. At point P_1 the waves have a path difference of an odd number of half wavelengths resulting in destructive interference

- In the diagram above, the number of wavelengths between:
 - $S_1 \rightarrow P_1 = 6\lambda$
 - $S_2 \rightarrow P_1 = 6.5\lambda$
 - $S_1 \rightarrow P_2 = 7\lambda$
 - $S_2 \rightarrow P_2 = 6\lambda$
- The path difference is:



Your notes

- $(6.5\lambda - 6\lambda) = \frac{\lambda}{2}$ at point P_1
- $(7\lambda - 6\lambda) = \lambda$ at point P_2
- Hence:
 - **Destructive interference** occurs at point P_1
 - **Constructive interference** occurs at point P_2

Conditions for Constructive and Destructive Interference

- In general, for waves emitted by two coherent sources very close together:
- The condition for **constructive interference** is:

$$\text{path difference} = n\lambda$$

- The condition for **destructive interference** is:

$$\text{path difference} = \left(n + \frac{1}{2}\right)\lambda$$

- Where:
 - λ = wavelength of the waves in metres (m)
 - $n = 0, 1, 2, 3, \dots$ (any other integer)

Path Difference and Wavefront Diagrams

- Wavefront diagrams show the interference between waves more clearly



Your notes

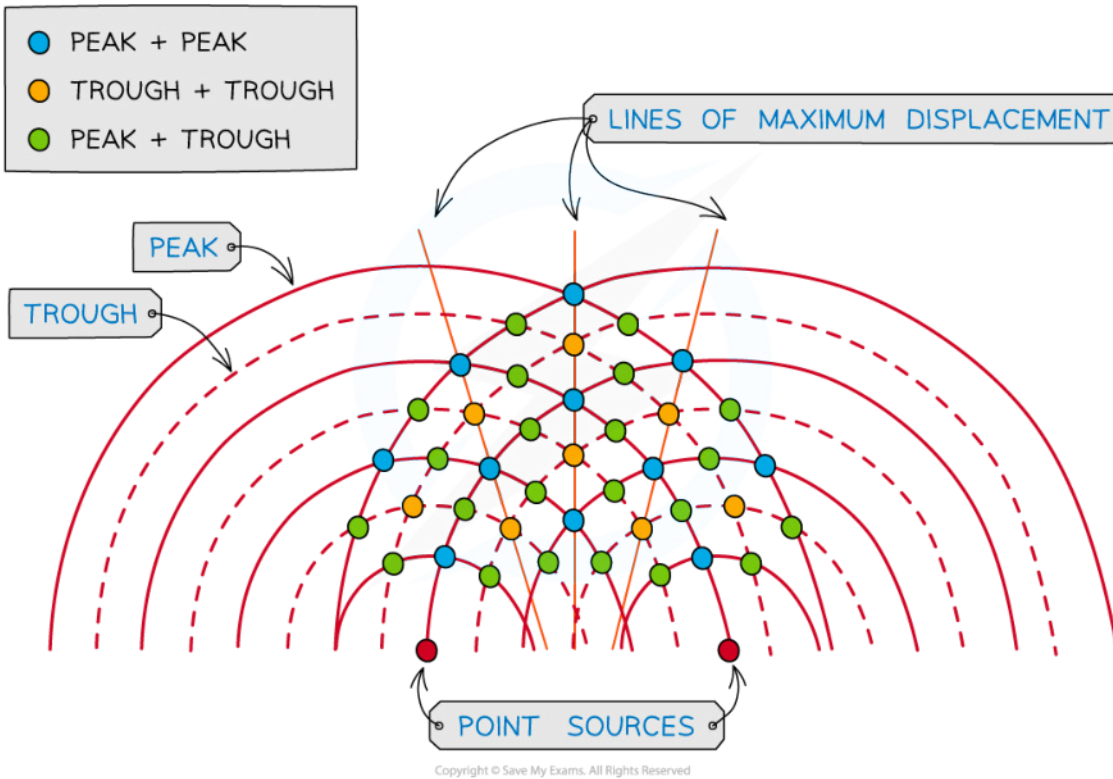

At the blue dot where the peak of two waves meet, constructive interference occurs. At the yellow dot where two troughs meet, constructive interference also occurs. Constructive interference occurs along the lines of maximum displacement. At the green dot, where a peak and a trough meet, destructive interference occurs

- On a wavefront diagram, it is possible to **count** the number of wavelengths to determine whether constructive or destructive interference occurs at a certain point

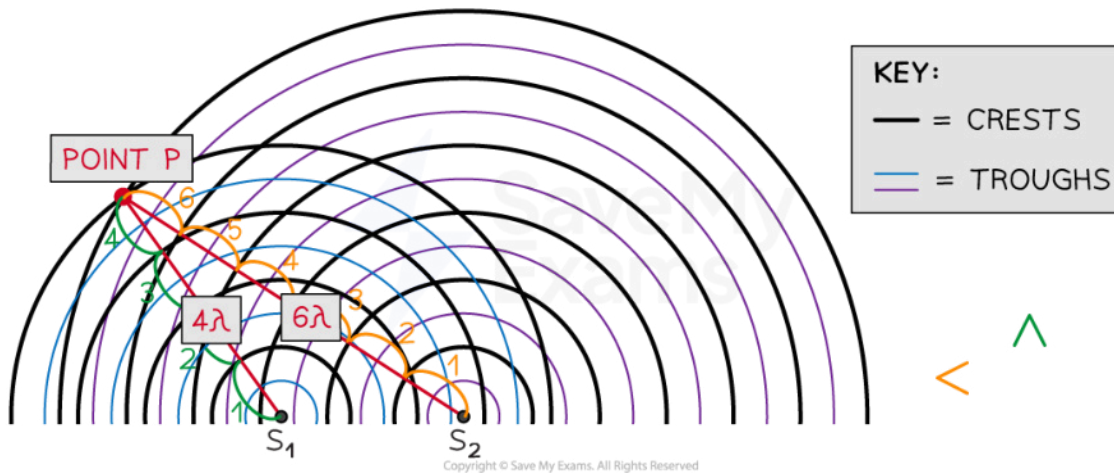

At point P the waves have a path difference of a whole number of wavelengths, resulting in constructive interference

- At point **P**, the number of **crests** from:
 - Source $S_1 = 4\lambda$
 - Source $S_2 = 6\lambda$
- So the path difference at **P** is $6\lambda - 4\lambda = 2\lambda$
- This is a whole number of wavelengths, hence, constructive interference occurs at point **P**



Your notes



Your notes

Worked example

The diagram shows the interferences of coherent waves from two-point sources.

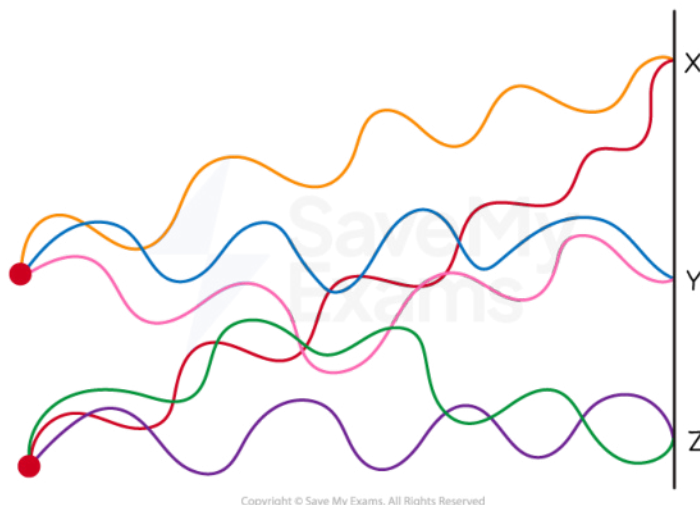

Which row in the table correctly identifies the type of interference at points X, Y and Z?

	X	Y	Z
A	Constructive	Destructive	Constructive
B	Constructive	Constructive	Destructive
C	Destructive	Constructive	Destructive
D	Destructive	Constructive	Constructive

Copyright © Save My Exams. All Rights Reserved

ANSWER: B

- At point X:
 - Both peaks of the waves are overlapping
 - Path difference = $5.5\lambda - 4.5\lambda = \lambda$
 - This is **constructive** interference and rules out options C and D
- At point Y:
 - Both troughs are overlapping
 - Path difference = $3.5\lambda - 3.5\lambda = 0$
 - Therefore **constructive** interference occurs

- At point **Z**:
 - A peak of one of the waves meets the trough of the other
 - Path difference = $4\lambda - 3.5\lambda = \lambda / 2$
 - This is **destructive** interference



Your notes

Worked example

The diagram below is a snapshot of overlapping wavefronts resulting from the interference of coherent waves diffracted by two narrow slits S_1 and S_2 .

KEY: — = CRESTS - - - = TROUGHS

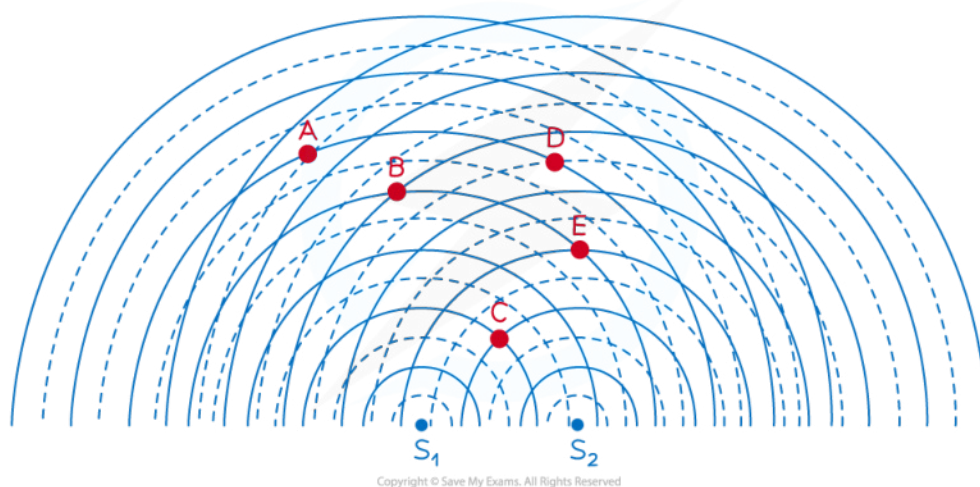

For each of the points A, B, C, D and E, determine:

- The path difference from the sources
- The value of n in the path difference formula
- Whether they are locations of constructive or destructive interference

Answer:

Step 1: Count the number of wavelengths between each source and the desired point

- For example, the number of wavelengths between:
 - $S_1 \rightarrow A = 5\lambda$
 - $S_2 \rightarrow A = 6.5\lambda$

Step 2: Determine the path difference by subtracting the distances of the point from the two sources

- For example, path difference at A = $(6.5\lambda - 5\lambda) = 1.5\lambda$

Step 3: Compare the path difference calculated in Step 2 with the condition for constructive or destructive interference and give the value of n

- For example, path difference at A = $1.5\lambda = (n + \frac{1}{2})\lambda \rightarrow n = 1$

Step 4: Decide whether the point is a location of constructive or destructive interference

- For example, at A, destructive interference occurs
- Point A:



Your notes

- Path difference = $(6.5\lambda - 5\lambda) = 1.5\lambda$
- $n = 1$
- Destructive interference
- Point B:
 - Path difference = $(5\lambda - 4\lambda) = \lambda$
 - $n = 1$
 - Constructive interference
- Point C:
 - Path difference = $(2\lambda - 2\lambda) = 0$
 - $n = 0$
 - Constructive interference
- Point D:
 - Path difference = $(5\lambda - 4.5\lambda) = 0.5\lambda$
 - $n = 0$
 - Destructive interference
- Point E:
 - Path difference = $(4\lambda - 3\lambda) = \lambda$
 - $n = 1$
 - Constructive interference

Examiner Tip

Remember, interference of two waves can either be:

- In **phase**, causing **constructive interference**. The peaks and troughs line up on both waves. The resultant wave has double the amplitude
- In **antiphase**, causing **destructive interference**. The peaks on one wave line up with the troughs of the other. The resultant wave has no amplitude

Think of '**constructive**' interference as '**building**' the wave and '**destructive**' interference as '**destroying**' the wave.

You are not required to memorise the specific conditions for constructive and destructive interference, as these are given in the data booklet.

You must be able to determine the path difference of waves from two sources (or two narrow slits) at a given point. You can then compare this with the given conditions for constructive and destructive interference, to decide which type of interference occurs at the point you are considering.



Your notes

Young's Double-Slit Experiment

Young's Double Slit Experiment

- Young's double-slit experiment produces a **diffraction** and an **interference pattern** using either:
 - The interference of two **coherent** wave sources
 - A single wave source passing through a **double slit**
- Lasers are the most common sources used in Young's double slit experiment because the waves must be:
 - Coherent** (have a constant phase difference and frequency)
 - Monochromatic** (have the same wavelength)
- In this typical set up for Young's double slit experiment:
 - The light source is placed behind the **single slit**
 - The light is then diffracted to produce two sources in the double slit at **A** and **B**
 - The light from the double slits is then diffracted, producing a **diffraction pattern** made up of bright and dark fringes on a screen

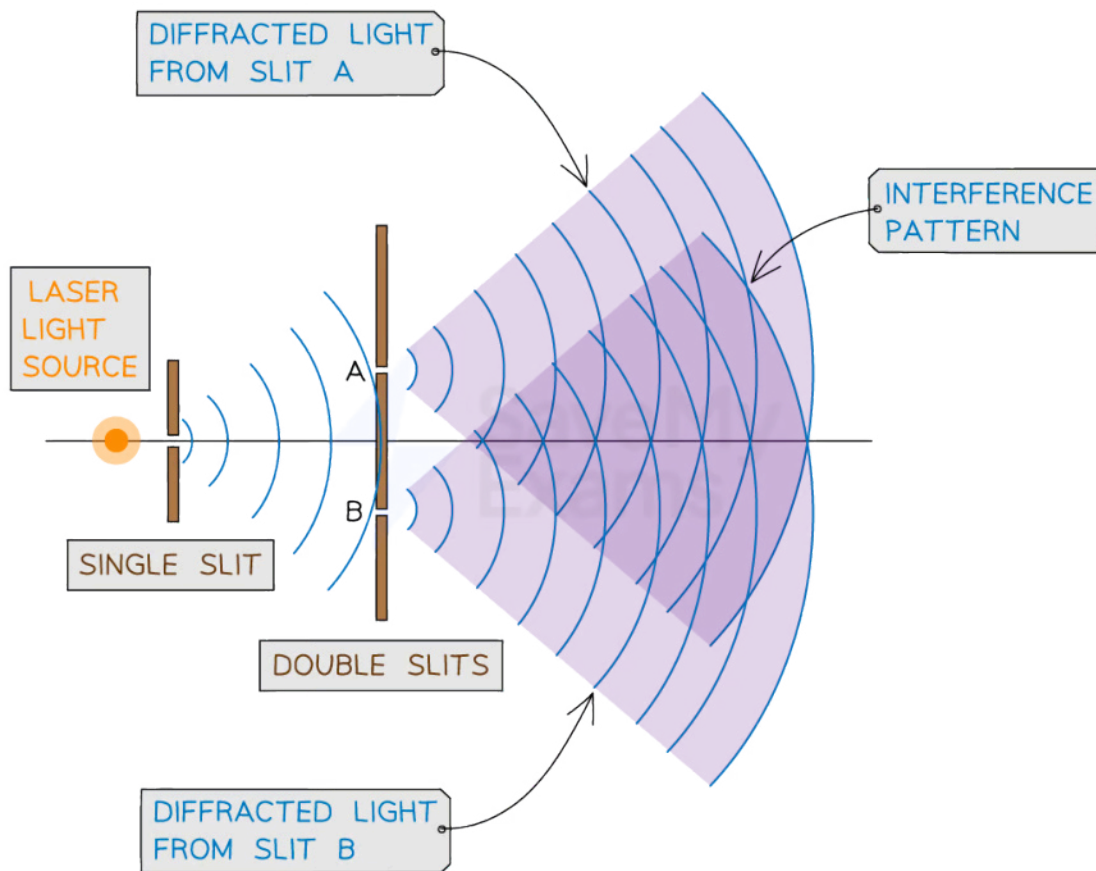

Copyright © Save My Exams. All Rights Reserved

The typical arrangement of Young's double slit experiment



Your notes

Diffraction Pattern

- The **diffraction pattern** from the interference of the two sources can be seen on the screen when it is placed far away
 - **Constructive interference** between light rays forms bright strips, also called **fringes**, interference fringes or **maxima**, on the screen
 - **Destructive interference** forms dark strips, also called dark **fringes** or **minima**, on the screen

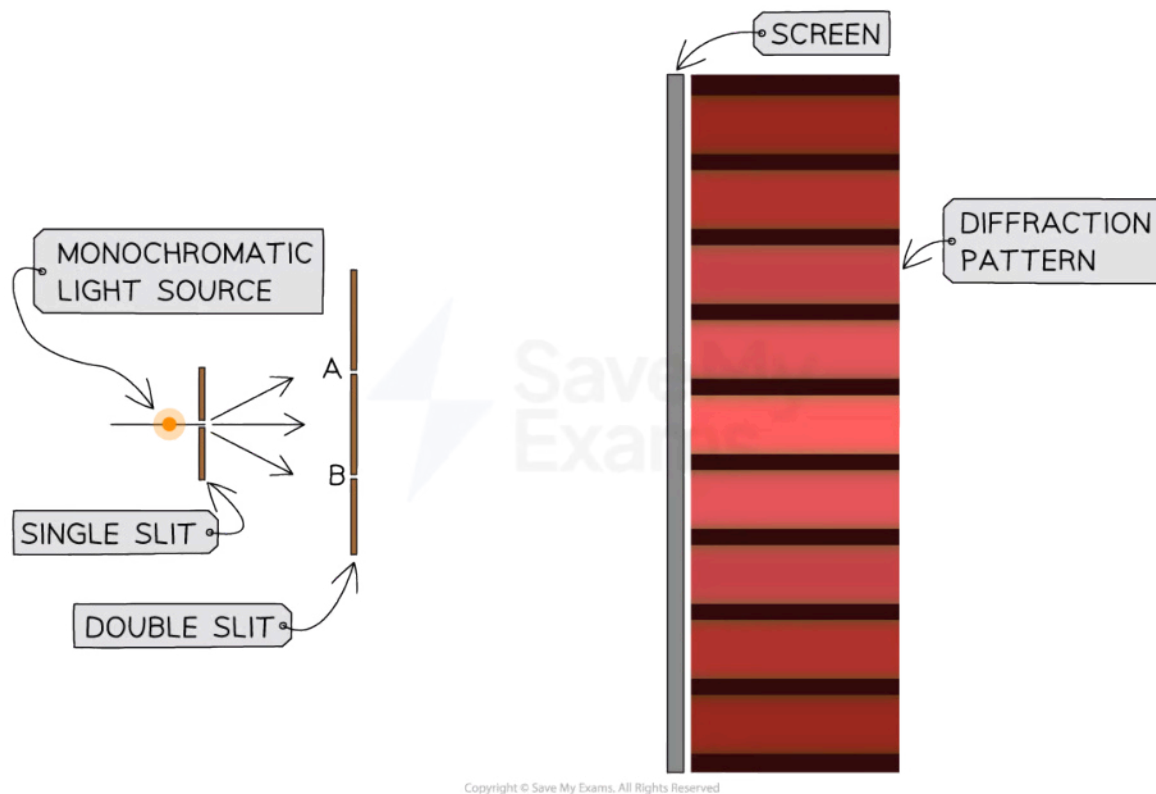

Young's double slit experiment and the resulting diffraction pattern

- Each bright fringe is **identical** and has the same width and intensity

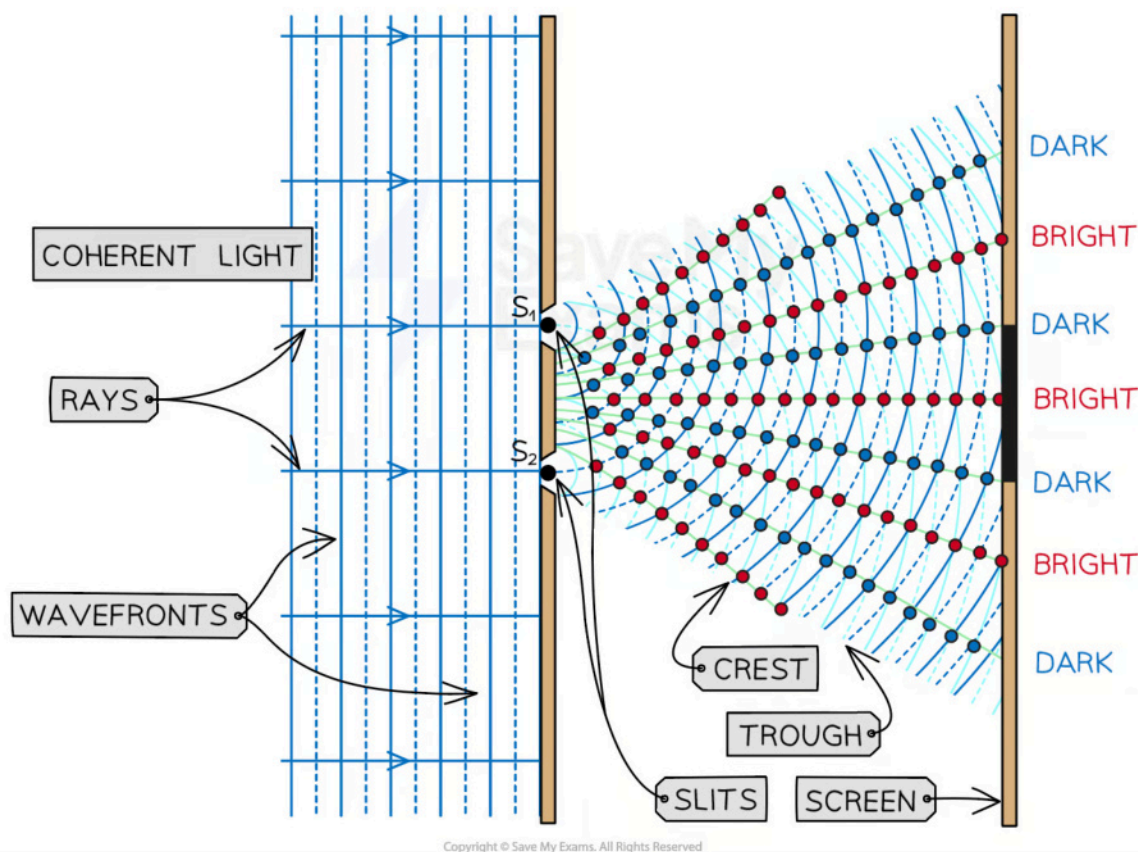

The constructive and destructive interference of laser light through a double slit creates bright and dark strips called fringes on a screen placed far away

Interference Pattern

- The Young's double slit interference pattern shows the regions of constructive and destructive interference:
 - Each **bright fringe** is a peak of equal **maximum intensity**
 - Each **dark fringe** is a trough or minimum of **zero intensity**
- The **maxima** are formed by the **constructive interference** of light
- The **minima** are formed by the **destructive interference** of light

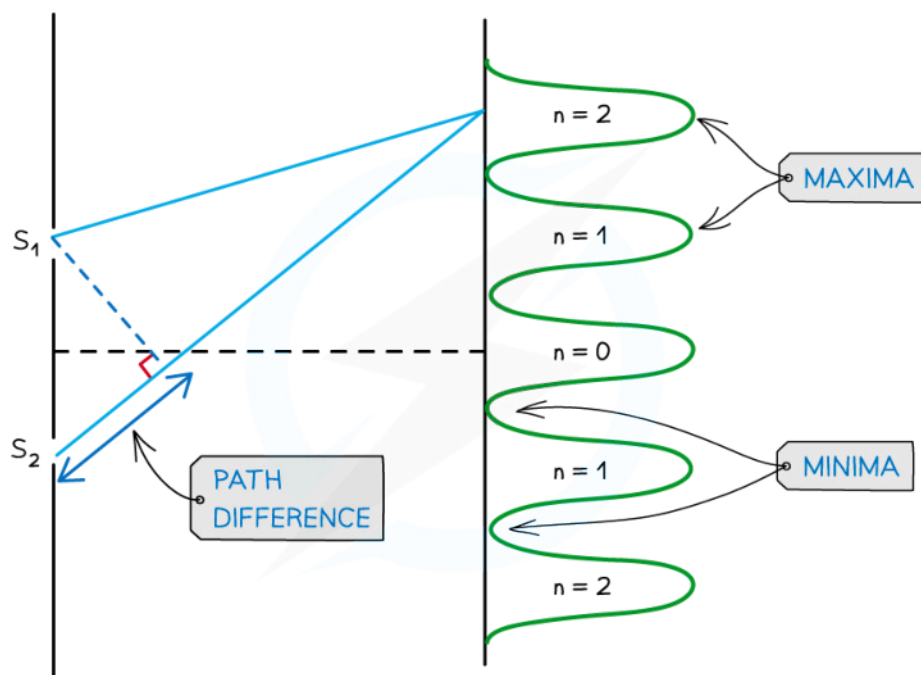

Copyright © Save My Exams. All Rights Reserved

The interference pattern of Young's double slit diffraction of light

- When two waves interfere, the resultant wave depends on the **path difference** between the two waves
- The wave from slit S_2 has to travel slightly further than that from S_1 to reach the same point on the screen
 - This extra distance is the **path difference**

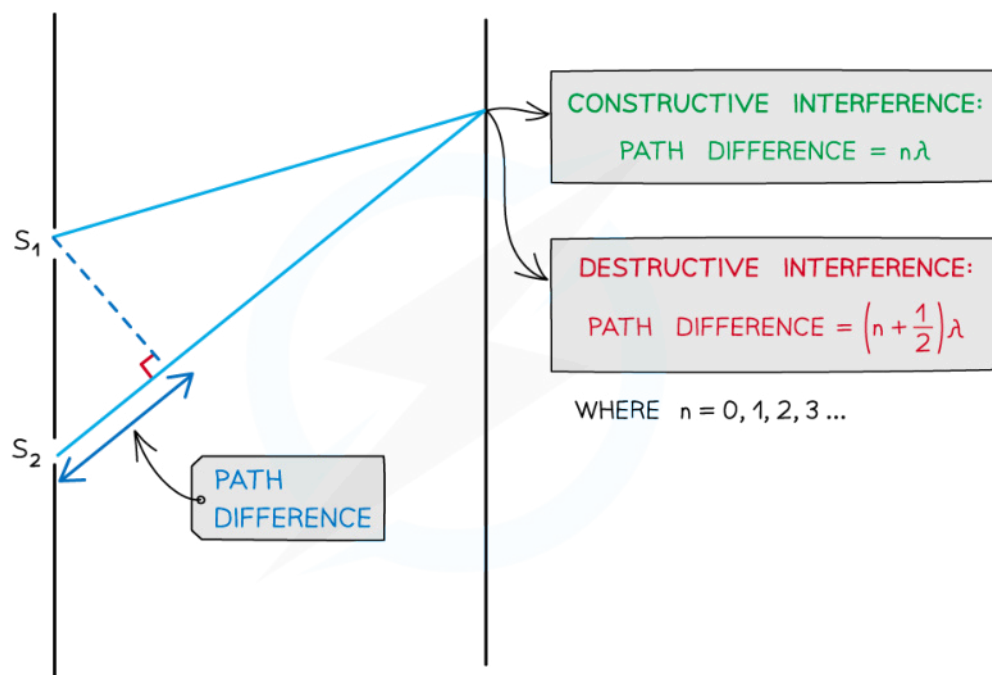

Copyright © Save My Exams. All Rights Reserved

The path difference between two waves is determined by the number of wavelengths that cover their difference in length

- Remember the conditions for interference as explained in the previous revision note on [double source interference](#)

- For **constructive** interference (or maxima):

$$\text{path difference} = n\lambda$$

- For **destructive** interference (or minima):

$$\text{path difference} = \left(n + \frac{1}{2}\right)\lambda$$

- For the maxima in the interference pattern:
 - There is usually more than one produced
 - n is the **order** of the maxima or minima; which represents the position of the maxima away from the central maximum
 - $n = 0$ is the **central** maximum
 - $n = 1$ represents the first maximum on either side of the central, $n = 2$ the next one along....

Double Slit Equation

- The spacing between the bright or dark fringes in the diffraction pattern formed on the screen can be calculated using the **double-slit** equation:



Your notes

$$s = \frac{\lambda D}{d}$$

- Where:
 - s = separation between successive fringes on the screen (m)
 - λ = wavelength of the waves incident on the slits (m)
 - D = distance between the screen and the slits (m)
 - d = separation between the slits (m)

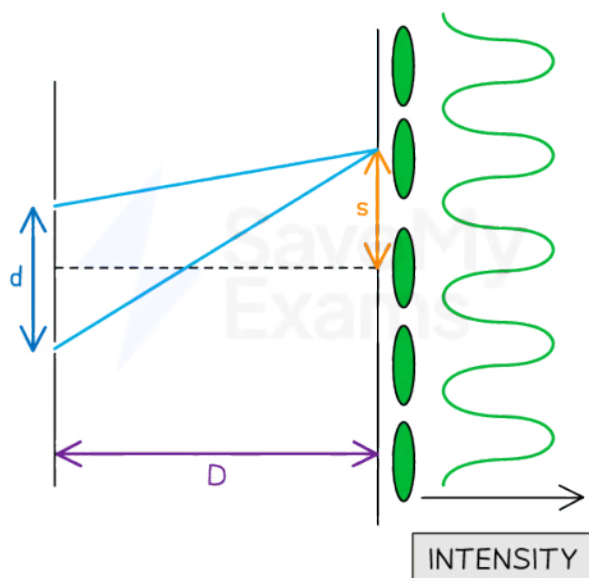

Copyright © Save My Exams. All Rights Reserved

Double slit interference equation with w , d and D represented on a diagram

- The above equation shows that the separation between the fringes, s will **increase** if:
 - The **wavelength** of the incident light **increases**
 - The **distance** between the screen and the slits **increases**
 - The **separation** between the slits **decreases**



Your notes

Worked example

Two coherent sources of sound waves S_1 and S_2 are situated 65 cm apart in air as shown below.

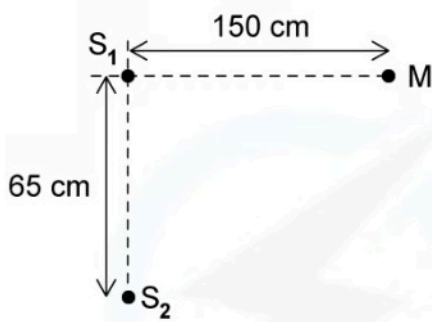

The two sources vibrate in phase but have different amplitudes of vibration. A microphone M is situated 150 cm from S_1 along the line normal to S_1 . The microphone detects maxima and minima of the intensity of the sound. The wavelength of the sound from S_1 to S_2 is decreased by increasing the frequency.

Determine which orders of maxima are detected at M as the wavelength is increased from 3.5 cm to 12.5 cm.

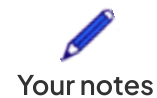

STEP 1

CALCULATE THE PATH DIFFERENCE

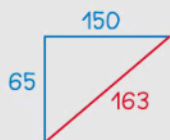

FROM PYTHAGORAS' THEOREM

$$\sqrt{65^2 + 150^2} = 163$$

$$\text{PATH DIFFERENCE} = 163 - 150 = 13 \text{ cm}$$

STEP 2

MAXIMA ARE CAUSED BY CONSTRUCTIVE INTERFERENCE

STEP 3

CONSTRUCTIVE INTERFERENCE:

$$\text{PATH DIFFERENCE} = n\lambda \quad n = 0, 1, 2, 3, \dots$$

STEP 4

$$13 = n\lambda$$

$$n = 0 \quad \lambda = 0$$

$$n = 1 \quad \lambda = \frac{13}{1} = 13 \text{ cm}$$

$$n = 2 \quad \lambda = \frac{13}{2} = 6.5 \text{ cm}$$

$$n = 3 \quad \lambda = \frac{13}{3} = 4.3 \text{ cm}$$

$$n = 4 \quad \lambda = \frac{13}{4} = 3.3 \text{ cm}$$

ONLY THESE TWO ORDERS
ARE WITHIN THE WAVELENGTH
RANGE.

WAVELENGTHS OF 6.5 cm AND
4.3 cm ARE WHERE MAXIMA
ARE DETECTED.



Your notes

 **Worked example**

A laser is placed in front of a double-slit as shown in the diagram below.

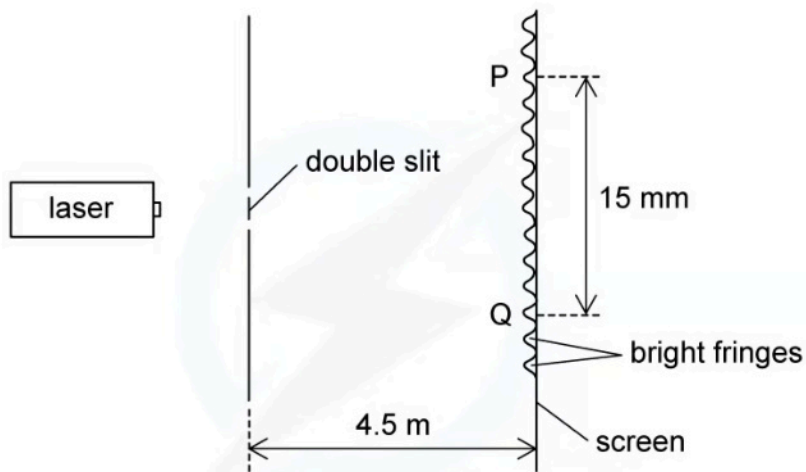

The laser emits light of frequency 750 THz. The separation of the maxima P and Q observed on the screen is 15 mm. The distance between the double slit and the screen is 4.5 m.

Calculate the separation of the two slits.



Your notes

STEP 1

CALCULATE THE WAVELENGTH OF THE LIGHT

$$v = f\lambda$$

STEP 2

REARRANGE FOR λ AND SUBSTITUTE IN VALUES

$$\lambda = \frac{v}{f} = \frac{3 \times 10^8}{750 \times 10^{12}} = 4 \times 10^{-7} \text{ m} = 400 \text{ nm}$$

STEP 3

FRINGE SPACING EQUATION

$$w = \frac{\lambda D}{S}$$

STEP 4

REARRANGE FOR S – SEPARATION OF THE TWO SLITS

$$S = \frac{\lambda D}{w}$$

STEP 5

SUBSTITUTE IN VALUES

$$s = \frac{4 \times 10^{-7} \times 4.5}{15 \times 10^{-3} \div 9} = 1.08 \times 10^{-3} \text{ m} = 1.1 \text{ mm (2 s.f.)}$$

TOTAL NUMBER OF
BRIGHT FRINGES

Copyright © Save My Exams. All Rights Reserved

Examiner Tip

The path difference is more specifically how much longer, or shorter, one path is than the other. In other words, the **difference** in the distances. Make sure not to confuse this with the distance between the two paths.

Since d , s and D are all distances, it's easy to mix up which they refer to. Labelling the double-slit diagram as shown in the notes above will help to remember the order i.e. d and s in the numerator and D underneath in the denominator.



Your notes

Single-Slit Diffraction (HL)

Single Slit Intensity Pattern

Single Slit Diffraction Pattern

- The **diffraction pattern** of monochromatic light passing through a single rectangular slit, is a series of light and dark fringes on a faraway screen
- This is similar to a double slit diffraction pattern:
 - The **bright fringes** are also areas of **maximum intensity**, produced by the **constructive interference** of each part of the wavefront as it passes through the slit
 - The **dark fringes** are also areas of zero or minimum **intensity**, produced by the destructive interference of each part of the wavefront as it passes through the slit

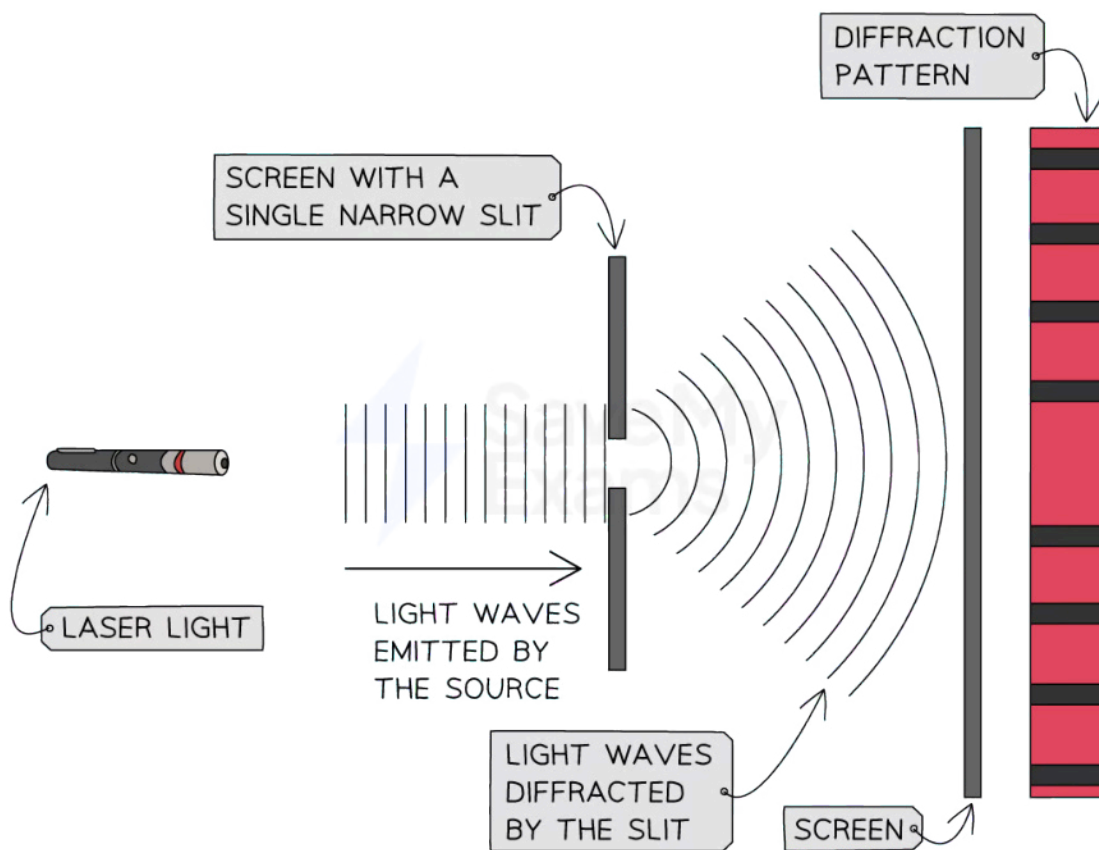

Copyright © Save My Exams. All Rights Reserved

The diffraction pattern produced by a laser beam diffracted through a single slit onto a screen is different to the diffraction pattern produced through a double slit

- However, the single and double-slit diffraction patterns are **different**
- The **central maximum** of the diffraction pattern is:



Your notes

- Much **wider and brighter** than the other bright fringes
- Much wider than that of the double-slit diffraction pattern
- On either side of the wide central maxima for the single slit diffraction pattern are much **narrower and less bright** maxima
 - These get **dimmer** as the **order increases**

Single Slit Intensity Pattern

- If a laser emitting blue light is directed at a single slit, where the slit width is similar in size to the wavelength of the light, its intensity pattern will be as follows:

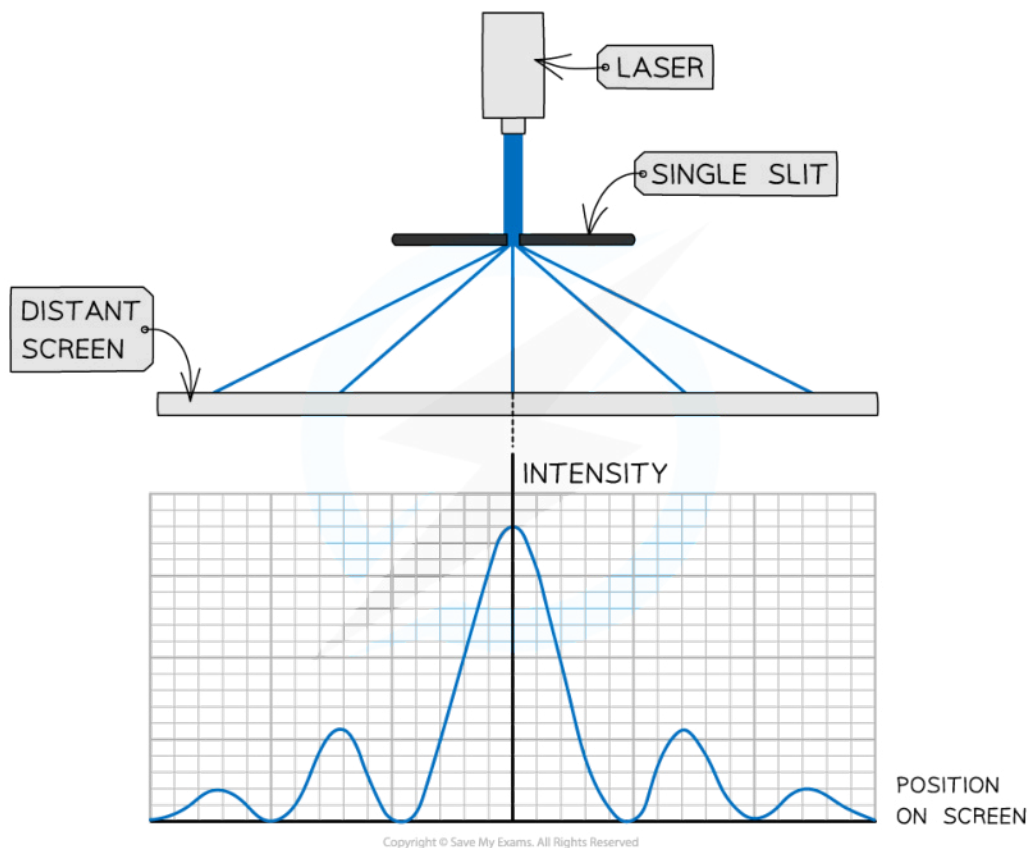

The intensity pattern of blue laser light diffracted through a single slit

- The features of the **single slit intensity** pattern are:
 - The **central bright fringe** has the **greatest intensity** of any fringe and is called the **central maximum**
 - The **dark fringes** are regions with **zero intensity**
 - Moving away from the central maxima either side, the **intensity** of each bright fringe **gets less**

Changes in Wavelength

- When the **wavelength** passing through the gap is increased then the wave **diffracts** more
- This increases the **angle of diffraction** of the waves as they pass through the slit



Your notes

- So the **width** of the **bright maxima** is also **increased**
- **Red** light
 - Which has the **longest wavelength** of visible light
 - Will produce a diffraction pattern with **wide fringes**
 - Because the angle of diffraction is wider
- **Blue** light
 - Which has a much **shorter wavelength**
 - Will produce a diffraction pattern with **narrow fringes**
 - Because the angle of diffraction is narrower

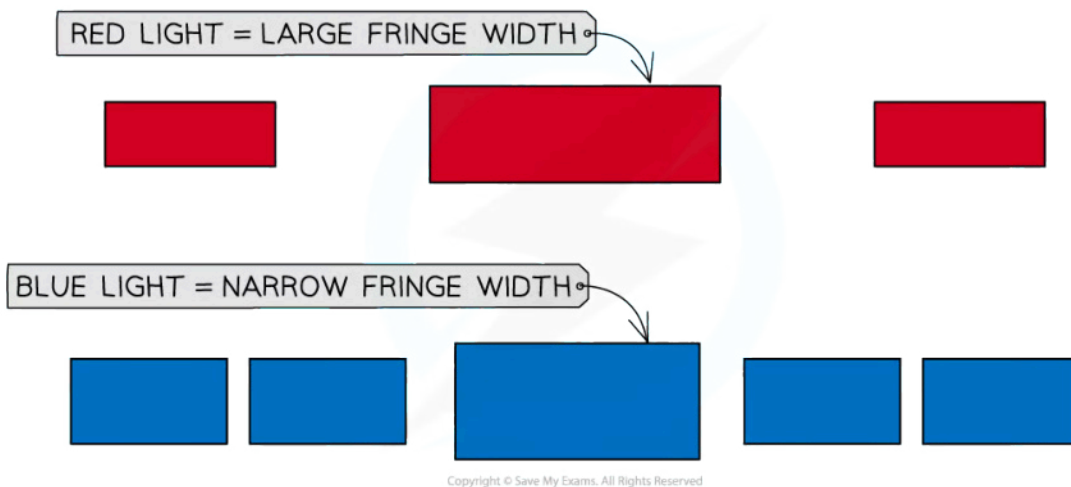

Fringe width depends on the wavelength of the light

- If the blue laser is replaced with a red laser:
 - There is **more diffraction** as the waves pass through the single slit
 - So the fringes in the intensity pattern would therefore be **wider**



Your notes

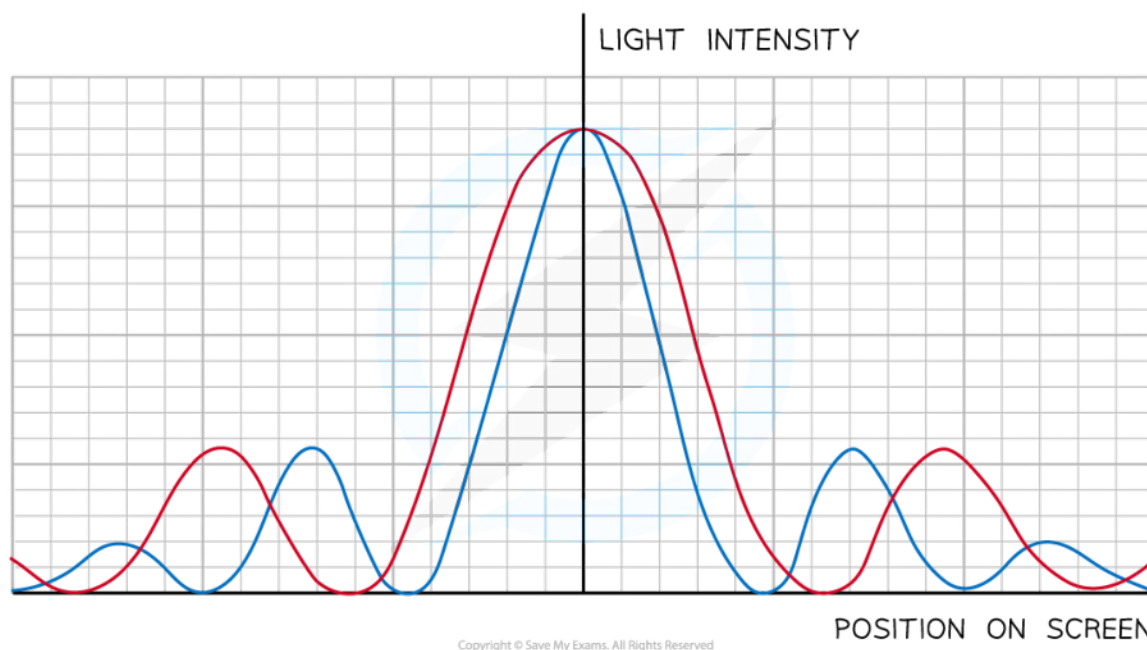

The intensity pattern of red laser light shows longer wavelengths diffract more than shorter wavelengths

Changes in Slit Width

- If the slit was made **narrower**:
 - The **angle** of diffraction is **greater**
 - So, the waves spread out more beyond the slit
- The **intensity graph** when the slit is made narrower will show that:
 - The intensity of the maxima **decreases**
 - The width of the central maxima **increases**
 - The spacing between fringes is **wider**

Single Slit Equation

- These properties of **wavelength** and **slit width** for single slit diffraction for the **first minima** can be explained using the equation:

$$\theta = \frac{\lambda}{b}$$

- Where:
 - θ = the angle of diffraction of the first minima ($^{\circ}$)
 - λ = wavelength (m)
 - b = slit width (m)
- Hence,
 - The **longer** the wavelength, the **larger** the angle of diffraction

- The **narrower** the slit width then the **larger** the angle of diffraction

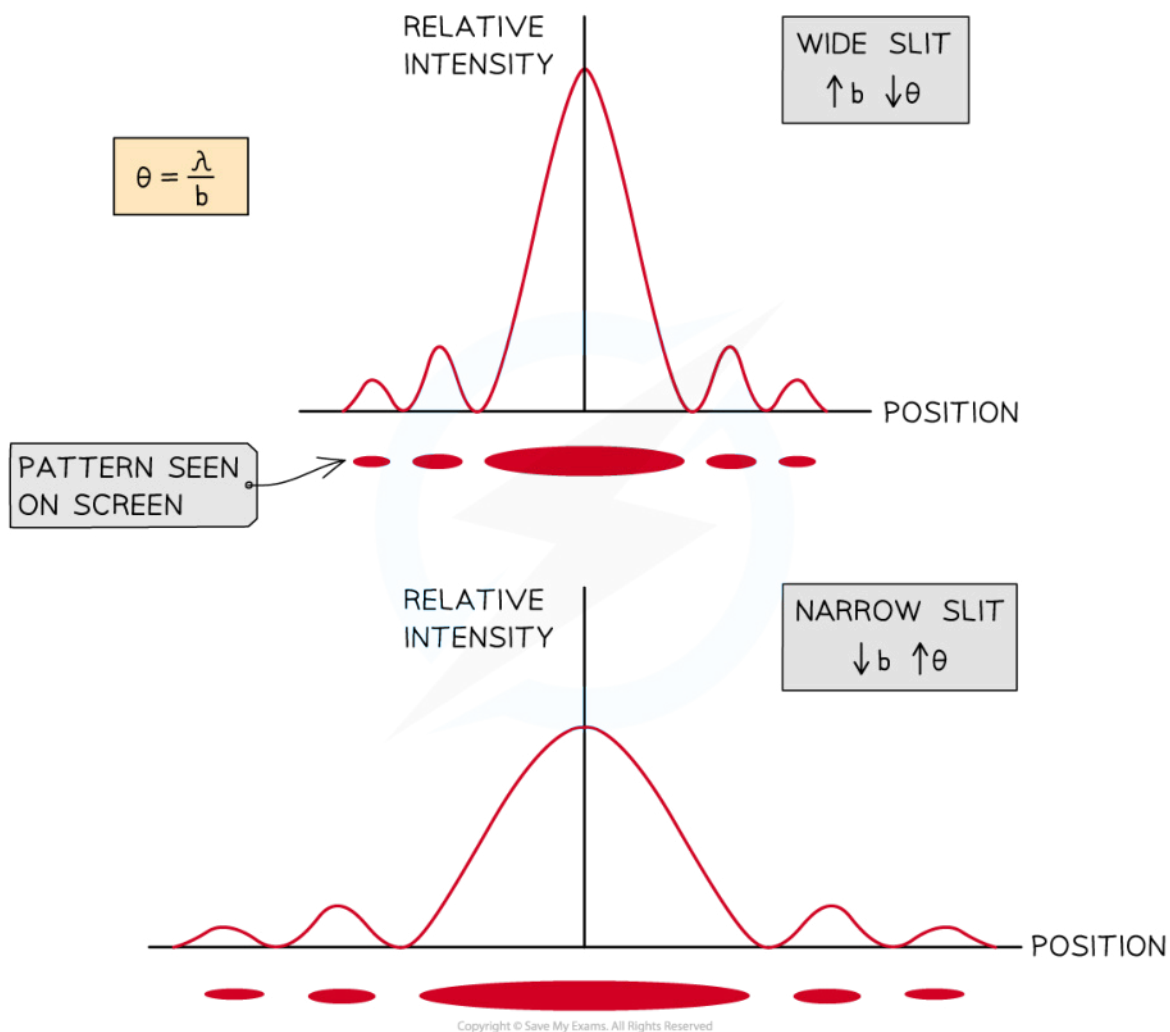

Slit width and angle of diffraction are inversely proportional. Increasing the slit width leads to a decrease in the angle of diffraction, hence the maxima appear narrower

Single Slit Geometry

- The diffraction pattern made by waves passing through a slit of width b can be observed on a screen placed a large distance away



Your notes

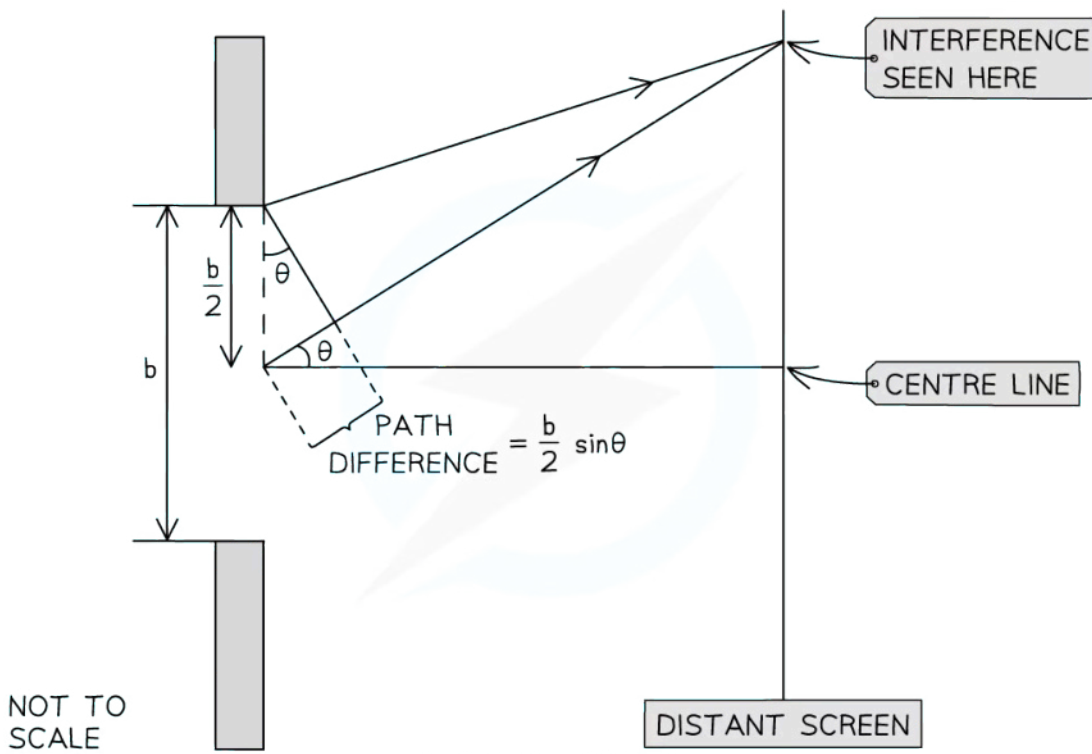

The geometry of single-slit diffraction

- If the distance, D , between the slit and the screen is considerably larger than the slit width, $D \gg b$:
 - The light rays can be considered as a set of plane wavefronts that are **parallel** to each other

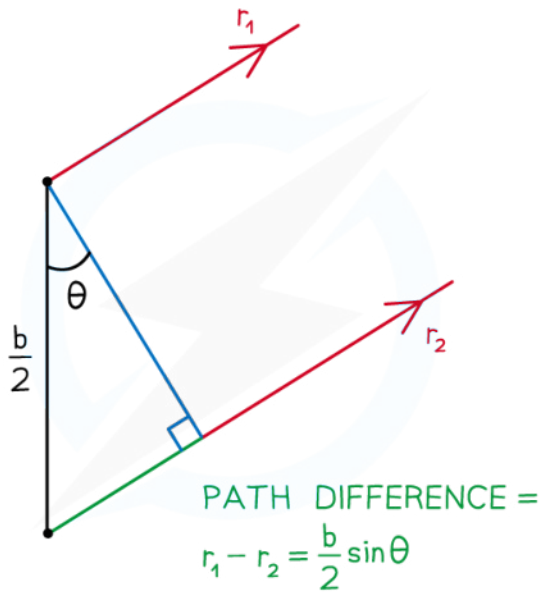

Determining the path difference using two parallel waves

- For two paths, r_1 and r_2 , travelling parallel to each other at an angle, θ , between the normal and the slit, the path difference will be:

$$\text{path difference} = r_1 - r_2 = \frac{b}{2} \sin \theta$$

- For a minima, or area of destructive interference:

The path difference must be a half-integral multiple of the wavelength

$$\text{path difference} = \frac{n\lambda}{2}$$

- Equating these two equations for path difference:

$$\frac{n\lambda}{2} = \frac{b}{2} \sin \theta$$

$$n\lambda = b \sin \theta$$

- Where n is a non-zero integer number, $n = 1, 2, 3, \dots$

- Since the angle θ is small, the small-angle approximation may be used: $\sin \theta \approx \theta$

$$n\lambda = b\theta$$

- Therefore, the first minima, $n = 1$, occurs at:

$$\lambda = b\theta$$

- This leads to the equation for **angle of diffraction** of the first minima:

$$\theta = \frac{\lambda}{b}$$



Your notes



Your notes

Worked example

A group of students are performing a diffraction investigation where a beam of coherent light is incident on a single slit with width, b .

The light is then incident on a screen which has been set up a distance, D , away.

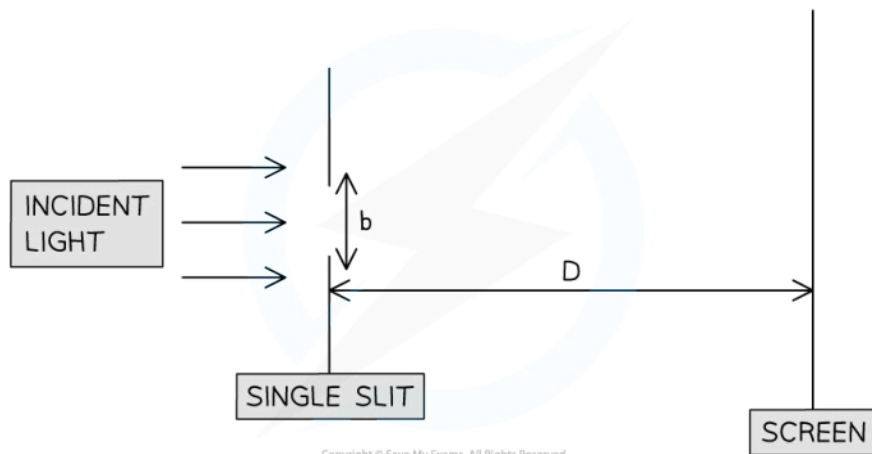

Copyright © Save My Exams. All Rights Reserved

A pattern of light and dark fringes is seen.

The teacher asks the students to change their set-up so that the width of the first bright maximum **increases**.

Suggest three changes the students could make to the set-up of their investigation which would achieve this.

Step 1: Write down the equation for the angle of diffraction

$$\theta = \frac{\lambda}{b}$$

- The width of the fringe is related to the size of the angle of diffraction, θ

Step 2: Use the equation to determine the factors that could increase the width of each fringe

Change 1

- The angle of diffraction, θ , is inversely proportional to the slit width, b

$$\theta \propto \frac{1}{b}$$

- Therefore, **reducing the slit width** would increase the fringe width

Change 2

- The angle of diffraction, θ , is directly proportional to the wavelength, λ

$$\theta \propto \lambda$$

- Therefore, **increasing the wavelength** of the light would increase the fringe width
Change 3
- The distance between the slit and the screen will also affect the width of the central fringe
- A larger distance means the waves must travel further hence, will spread out more
- Therefore, **moving the screen further away** would increase the fringe width



Your notes



Your notes

Double Slit Modulation

- When light passes through a double slit **two types** of interference occur:
 - The diffracted rays passing through one slit interfere with the rays passing through the other
 - Rays passing through the same slit interfere with each other
- This produces a double-slit **intensity pattern** where the single-slit intensity pattern **modulates** (adjusts) the intensity of the light on the screen
 - It looks like a **double-slit interference pattern** inscribed in the **single-slit intensity pattern**

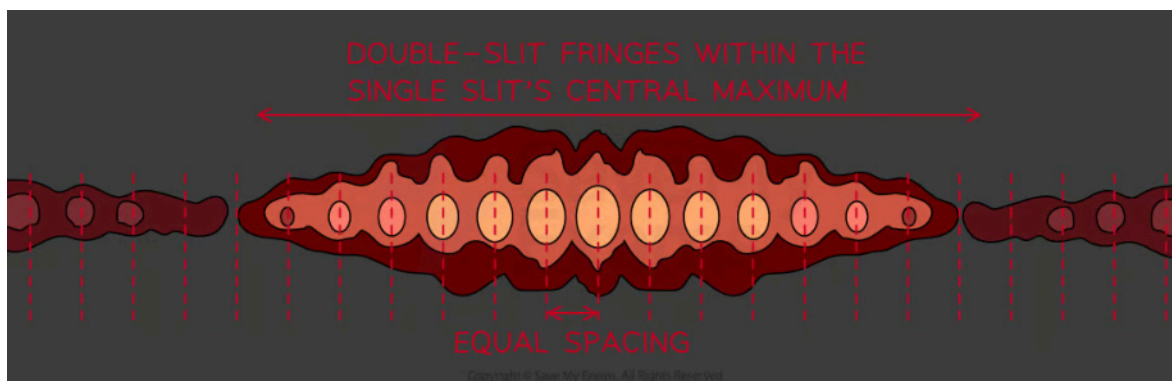

The double slit interference pattern is modulated inside the single slit intensity pattern

- The **single-slit intensity pattern** has a distinctive **central** maximum and **subsequent** maxima at lower intensity
- The double-slit interference pattern has **equally** spaced intensity peaks with maxima of **equal** intensity
- Together, the combined double slit intensity pattern has equally spaced bright fringes but now within a single slit '**envelope**'



Your notes

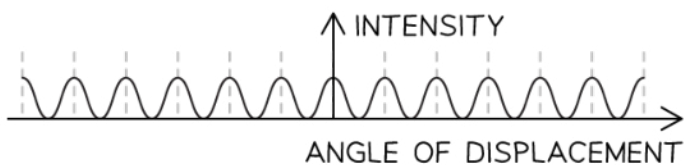

DOUBLE SLIT INTERFERENCE PATTERN

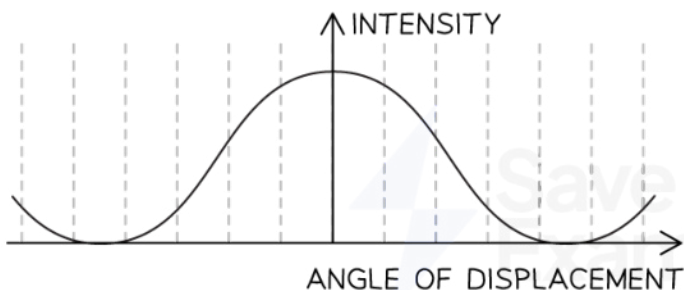

SINGLE SLIT INTENSITY PATTERN

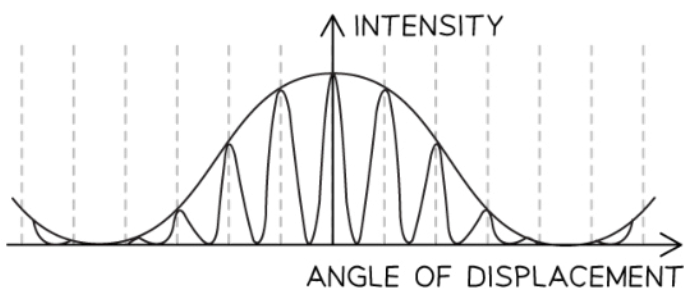

DOUBLE SLIT INTENSITY PATTERN

Copyright © Save My Exams. All Rights Reserved

Combined single-slit intensity pattern and double-slit interference pattern

- This is assuming that:
 - The slit width is not negligible
 - The distance between the slits is much greater than their width



Your notes

Diffraction Gratings (HL)

The Diffraction Grating

- A diffraction grating is a piece of **optical equipment** that also creates a **diffraction pattern** when light is passed through it
- Diffraction gratings diffract::
 - Monochromatic light into bright and dark fringes
 - White light into its different wavelength components

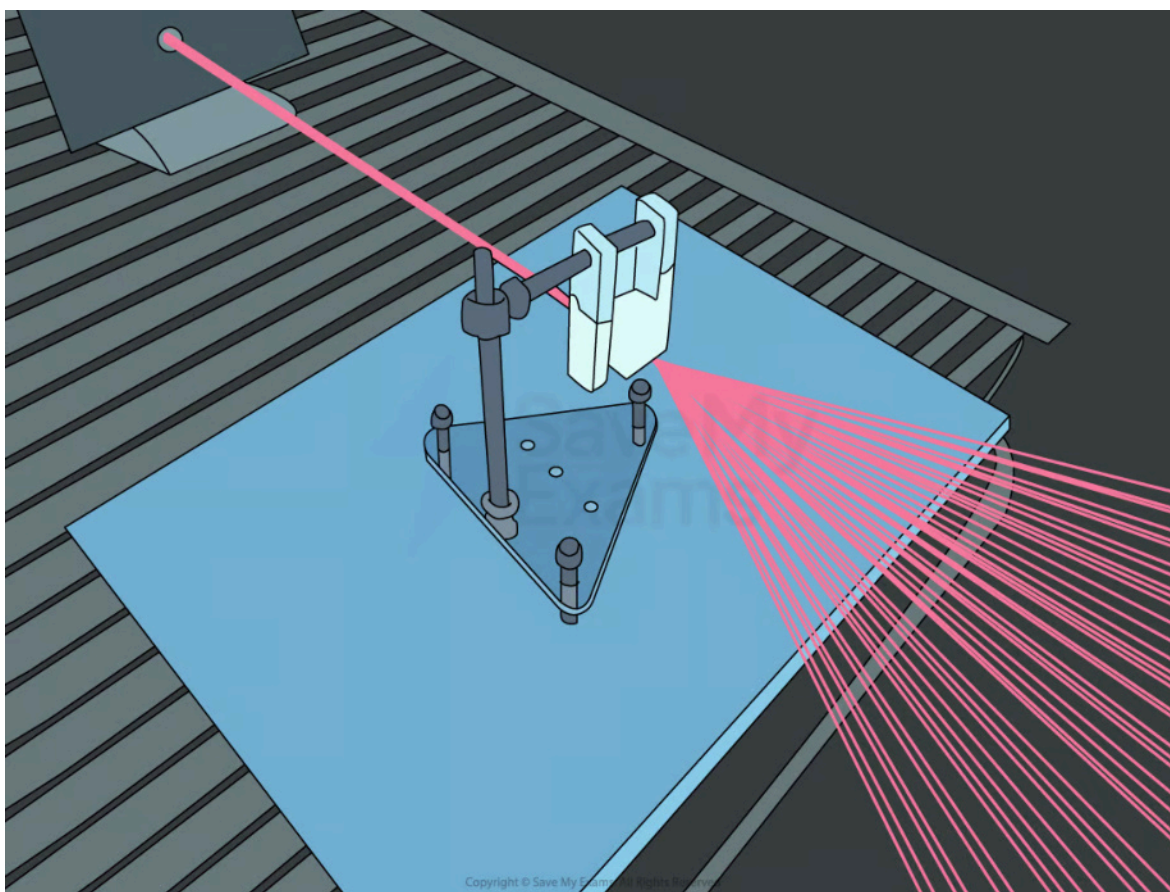

A laser beam is diffracted through a diffraction grating

- A diffraction grating consists of a **large number** of very **thin, equally spaced parallel slits** carved into a glass plate



Your notes

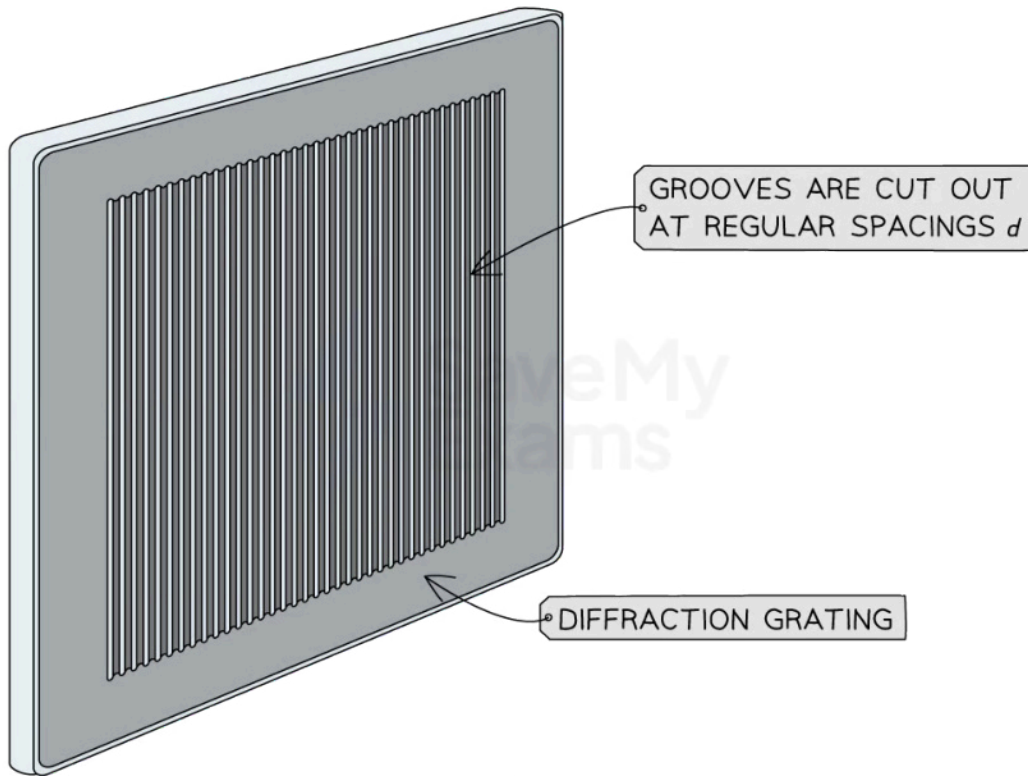

Copyright © Save My Exams. All Rights Reserved

A diffraction grating consists of many parallel equally spaced slits cut into the glass plate



Your notes

SIDE
VIEW

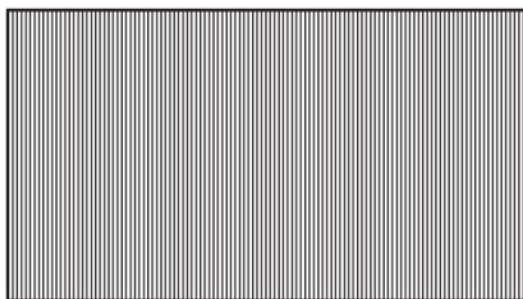

TOP-
DOWN
VIEW

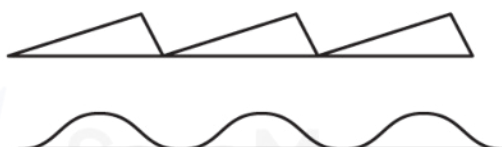

MAGNIFIED
VIEW

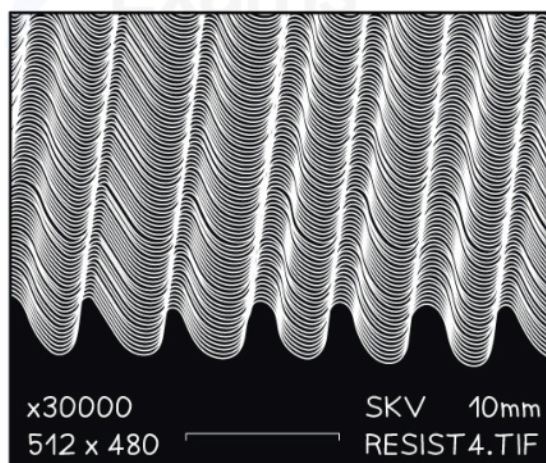

Copyright © Save My Exams. All Rights Reserved

When you look closely at a diffraction grating you can see the curved shape of the slits

The Diffraction Grating Equation

- Diffraction gratings are useful because they create a **sharper pattern** than a double slit
 - This means their **bright fringes** are **narrower** and **brighter** while their dark regions are wider and darker

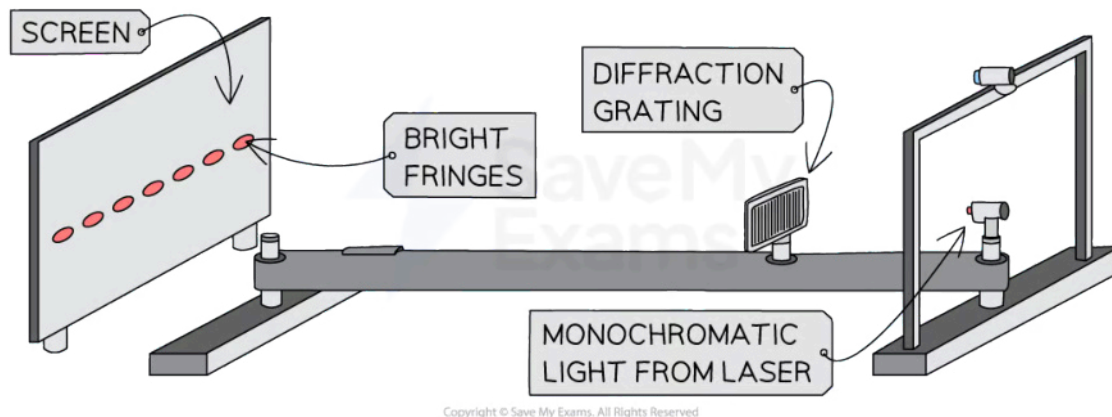

Copyright © Save My Exams. All Rights Reserved

A diffraction grating is used to produce narrow bright fringes when laser light is diffracted through it

- Just like for single and double-slit diffraction the regions where **constructive interference** occurs are also the regions of **maximum intensity**
- Their location can be calculated using the **diffraction grating equation**

$$d \sin(\theta) = n\lambda$$

Diagram illustrating the diffraction grating equation $d \sin(\theta) = n\lambda$ with labels:

- ANGULAR SEPARATION BETWEEN THE ORDER OF MAXIMA (DEGREES)** points to θ
- WAVELENGTH OF SOURCE (m)** points to λ
- SPACING BETWEEN ADJACENT SLITS (m)** points to d
- ORDER OF MAXIMA $n = 0, 1, 2, 3 \dots$** points to n

Copyright © Save My Exams. All Rights Reserved

- Where:
 - n is the order of the maxima, the number of the maxima away from the central ($n = 0$)
 - d is the distance between the slits on the grating (m)
 - θ is the angle of diffraction of the light of order n from the normal as it leaves the diffraction grating ($^\circ$)
 - λ is the wavelength of the light from the source (m)

Number of Slits

- Increasing the number of slits increases the number and intensity of the maxima in the intensity pattern**
 - This is because **more slits** means **more diffraction** and **more constructive interference**

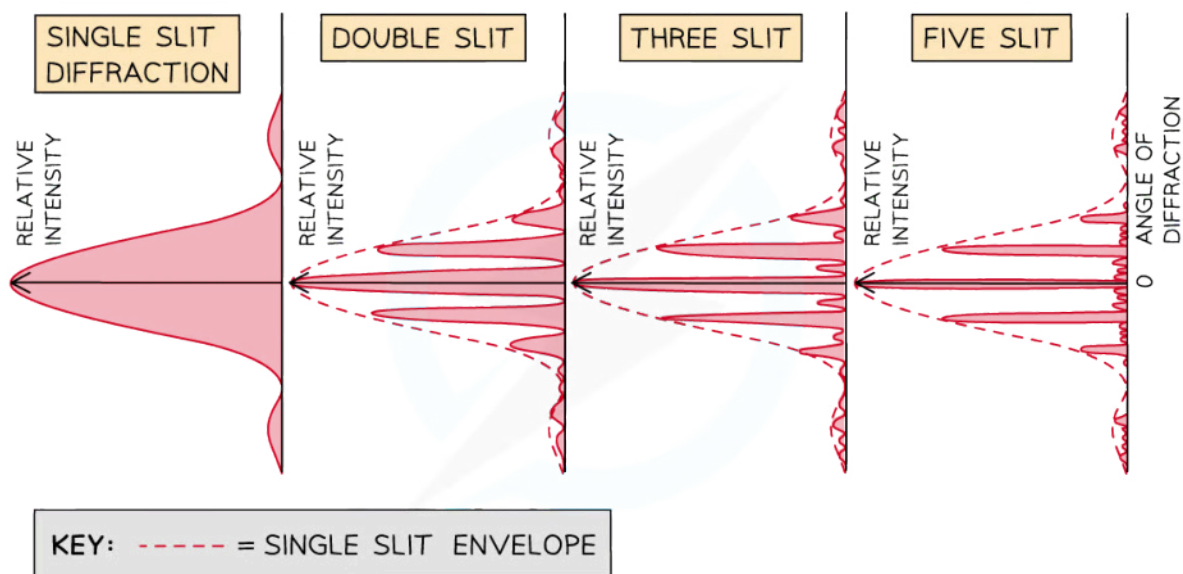

Copyright © Save My Exams. All Rights Reserved

The combined diffraction and interference patterns, called the intensity pattern, for light interfering through different numbers of slits. The maximum intensity increases as the number of slits increases, so the intensity in each graph is relative to that number of slits only

Slit Spacing

- Diffraction gratings come in **different sizes**
 - The sizes are determined by the number of **lines per millimetre** (lines / mm) or lines per m
 - This is represented by the symbol N
- d can be calculated from N using the equation
 - If N is given in terms of lines per mm then d will be in mm
 - If N is given in terms of lines per m then d will be in m

$$d = \frac{1}{N}$$

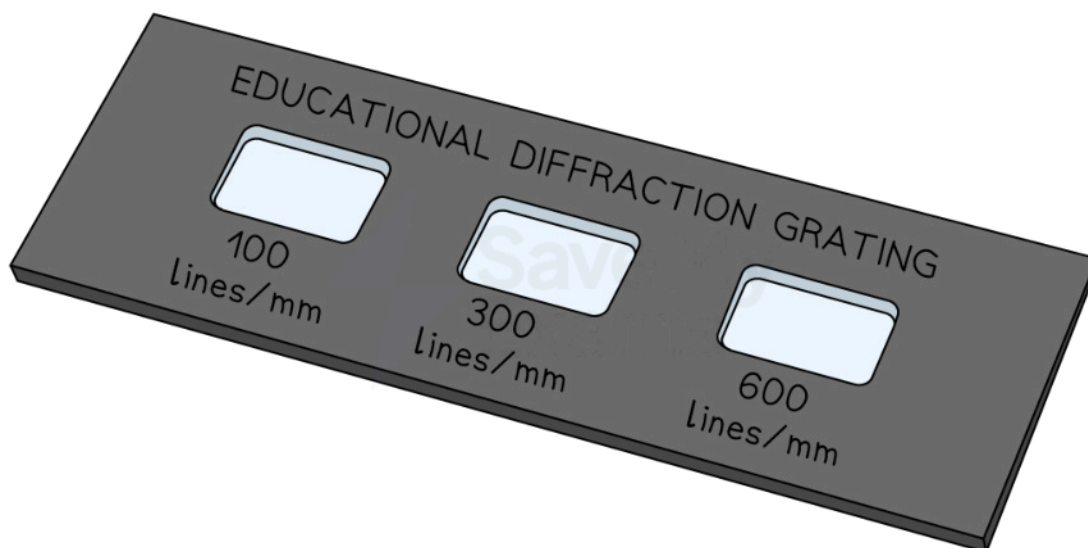

Copyright © Save My Exams. All Rights Reserved

Diffraction gratings come in different sizes according to the number of lines per mm

Angular Separation

- The angular separation of each maxima is calculated by rearranging the grating equation to make θ the subject
- The angle θ is taken from the centre meaning the higher orders of n are at greater angles of diffraction

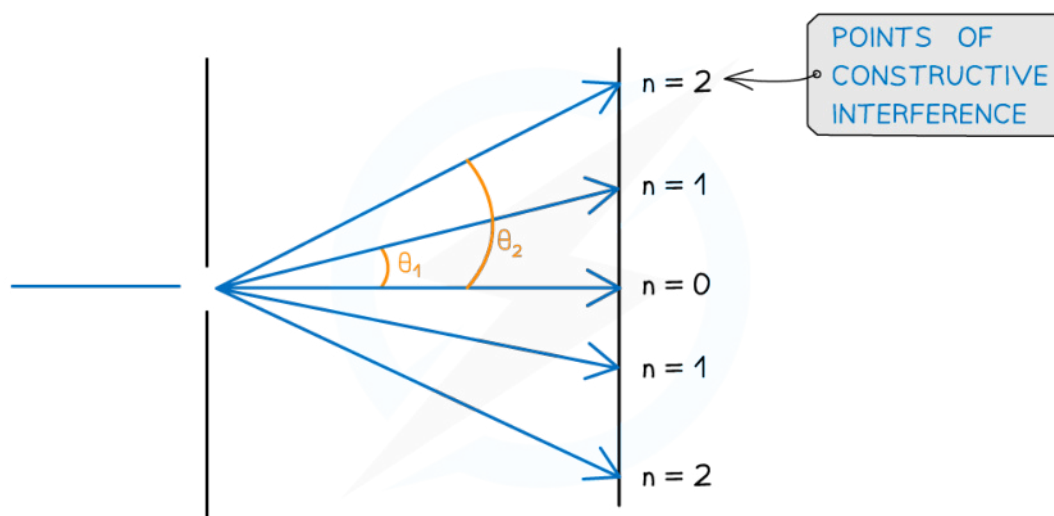

Copyright © Save My Exams. All Rights Reserved

Angular separation increases as the order of maxima increases



Your notes

- The angular separation between two angles is found by subtracting the smaller angle from the larger one
- The angular separation between the first and second maxima at n_1 and n_2 is $\theta_2 - \theta_1$

Orders of Maxima

- The maximum angle of diffraction with which maxima can be seen is when the beam is at right angles to the diffraction grating
 - This means $\theta = 90^\circ$ and $\sin \theta = 1$
- The highest order of maxima visible is therefore calculated by the equation:

$$n = \frac{d}{\lambda}$$

- Since n is an integer number of maxima, if the value obtained is a decimal it must be rounded **down** to determine the highest-order visible
 - E.g If n is calculated as 2.7 then $n = 2$ is the highest-order visible

The Diffraction of White Light

- A source of white light diffracted through a diffraction grating will produce the following **diffraction pattern**:
 - It is different to that produced by a double or single slit
 - The first-order spectrum $n = 1$ is used for analysis
- The central maximum is a **very thin bright strip** because each wavelength interferes here constructively
 - It is surrounded by wide dark destructive interference fringes
- All other maxima are composed of a **spectrum**
- **Separate** diffraction patterns can be observed for each wavelength of light
 - The shortest wavelength (violet / blue) would appear **nearest** to the central maximum because it is diffracted the **least**
 - The longest wavelength (red) would appear **furthest** from the central maximum because it is diffracted the **most**
- The colours look **blurry** and further away from the central maximum, the fringe spacing gets so small that the spectra eventually merge without any space between them
 - As the maxima move **further away** from the central maximum, the wavelengths of **blue** observed **decrease** and the wavelengths of **red** observed **increase**

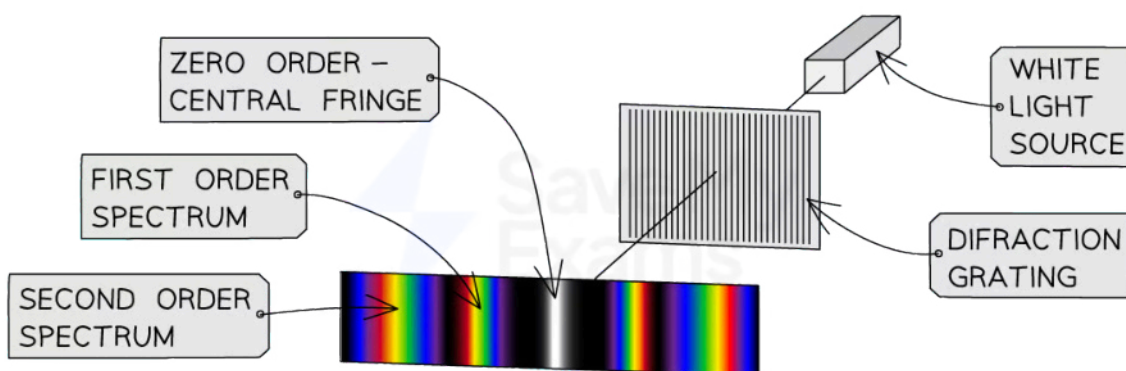

Copyright © Save My Exams. All Rights Reserved

The diffraction pattern of white light diffracted through a diffraction grating

Worked example

An experiment was set up to investigate light passing through a diffraction grating with a slit spacing of $1.7 \mu\text{m}$. The fringe pattern was observed on a screen. The wavelength of the light is 550 nm .

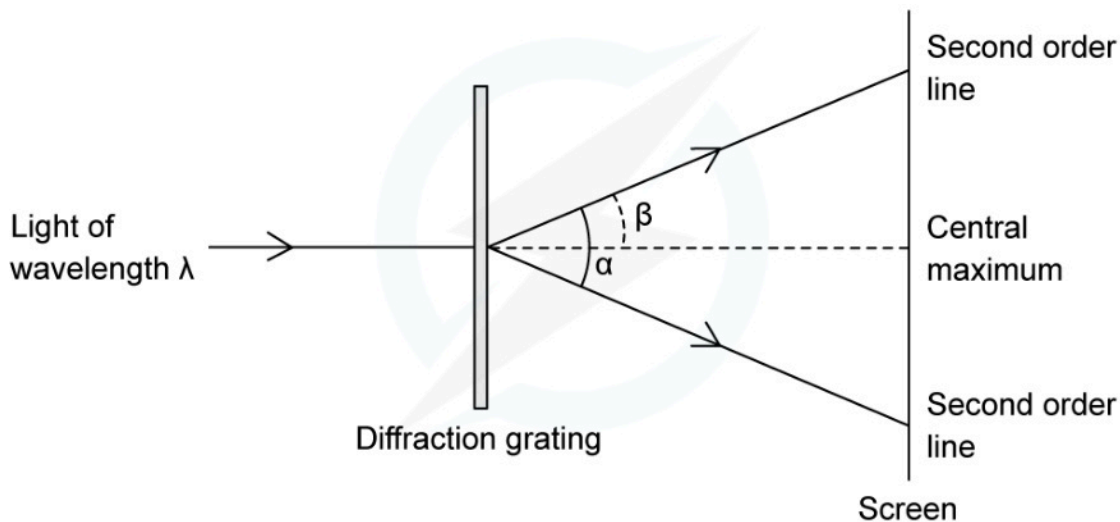

Calculate the angle α between the two second-order lines.



Your notes

STEP 1

DIFFRACTION GRATING EQUATION

$$d \sin(\theta) = n\lambda$$

 $n = 2$ FOR THE SECOND ORDER LINE

$$D = 1.7 \mu\text{m}$$

$$\lambda = 550 \text{ nm}$$

STEP 2

 REARRANGE FOR $\sin(\theta)$

$$\sin(\theta) = \frac{n\lambda}{d}$$

STEP 3

SUBSTITUTE IN VALUES

$$\sin(\theta) = \frac{2 \times 550 \times 10^{-9}}{1.7 \times 10^{-6}} = 0.64705\dots = 0.65 \text{ (2 s.f.)}$$

STEP 4

 FIND θ THROUGH THE INVERSE SINE

$$\sin^{-1}(0.65) = 40.54^\circ$$

STEP 5

 θ IS ANGLE FROM THE CENTRE TO THE SECOND ORDER LINE (β ON THE DIAGRAM)

$$d = \theta \times 2 = 81^\circ \text{ (2 s.f.)}$$

Copyright © Save My Exams. All Rights Reserved

Examiner Tip

Take care that the angle θ is the correct angle taken from the centre and **not** the angle taken between two orders of maxima.