



HL IB Physics

Your notes

Induction

Contents

- * Induced Emf (HL)
- * Magnetic Flux (HL)
- * Faraday's Law of Induction (HL)
- * Lenz's Law (HL)
- * AC Generators (HL)



Your notes

Induced Emf (HL)

Induced e.m.f.

- Electromagnetic induction is a phenomenon which occurs when an e.m.f. is induced due to **relative movement** between a conductor and a magnetic field
- This could occur when:
 - a **conductor** moves relative to a magnetic field
 - a **magnetic field** varies relative to a conductor
- When a conductor cuts through magnetic field lines:
 - the free electrons in the conductor experience a **magnetic force**
 - this causes **work to be done** as charges in the conductor become **separated**
 - mechanical work is **transferred** to the charges as electric potential energy
 - a potential difference is created between the ends of the conductor, or in other words, an **e.m.f. is induced**
- This induced e.m.f. is defined as:

The amount of work done per unit charge in separating the charges to the ends of a conductor
- If the ends of the conductor are connected to a closed circuit, an **induced current** will be able to flow
- Therefore, we can define **electromagnetic induction** as:

The process in which an e.m.f or current is induced in a closed circuit due to changes in magnetic flux
- To induce a current in a straight **current-carrying conductor** in a magnetic field
 - it must be placed in a **perpendicular** field, so when it moves it **cuts** the magnetic field lines
 - the closed circuit must be positioned **outside** of the field, so the e.m.f. is induced across the conductor in the field **only**, and **not** the entire circuit (which would mean no current flow)

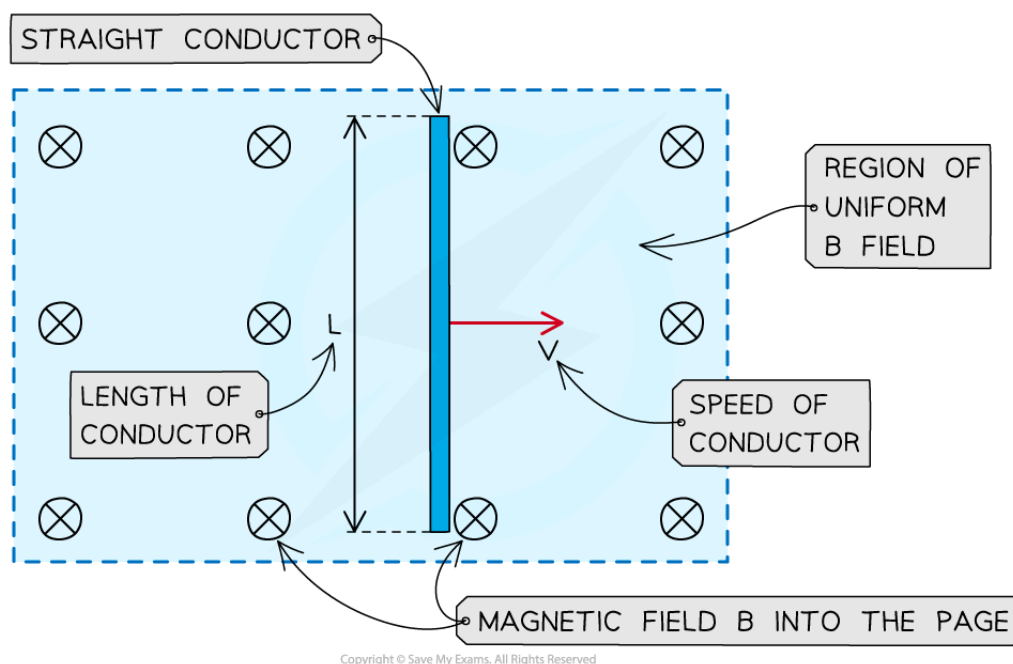

Conducting rod moving perpendicular to a magnetic field directed into the page

- The induced e.m.f in the conductor, as it moves through the magnetic field, is:

$$\varepsilon = BLv$$

- Where:

- ε = induced e.m.f. (V)
- B = magnetic flux density (T)
- L = length of the conductor in the field (m)
- v = velocity of the conductor travelling through the field (m s^{-1})

- This equation shows that the size of the induced e.m.f increases if:

- the **length** of the conductor in the field is increased
- the magnetic field **strength** is increased
- the conductor cuts through the field lines **faster**

- Coiling a wire to form many loops or turns, will also increase the size of the induced e.m.f.

- For a coil moving through a magnetic field, the induced e.m.f. is:

$$\varepsilon = BLvN$$

- Where N = number of turns on the coil

- The phenomenon of EM induction can be demonstrated using a magnet and a coil, or a wire and two magnets

Experiment 1: Moving a magnet through a coil

- When a coil is connected to a sensitive voltmeter, a bar magnet can be moved in and out of the coil to induce an e.m.f

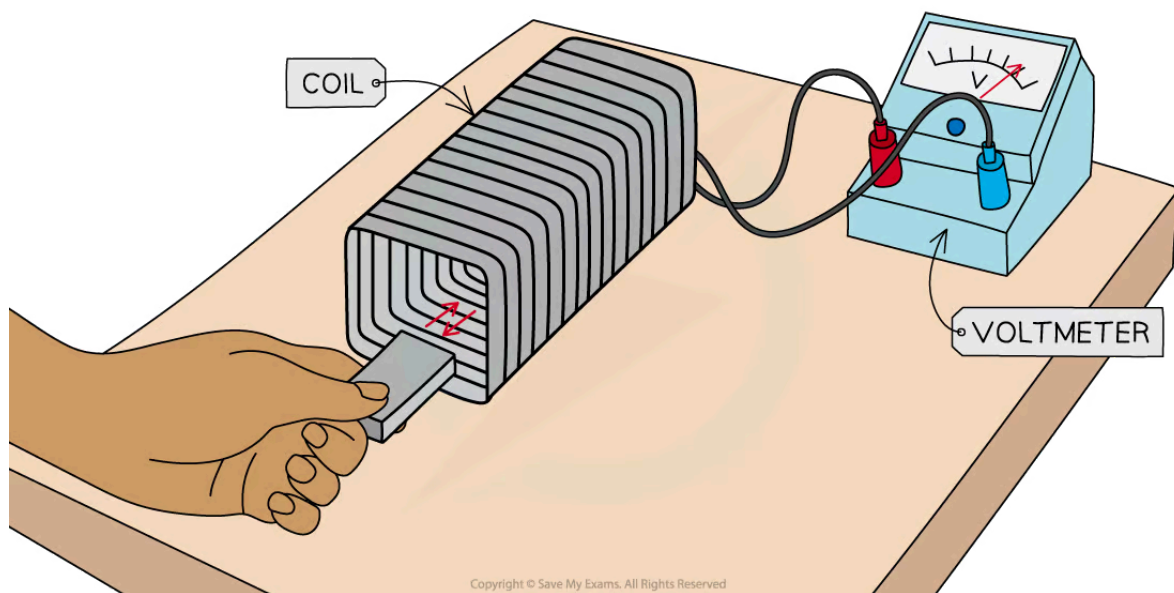

A bar magnet is moved through a coil connected to a voltmeter to induce an e.m.f

The expected results are...

1. When the bar magnet is not moving, the voltmeter shows a zero reading

- When the bar magnet is held still inside, or outside, the coil, the rate of change of flux is zero, so, there is **no e.m.f induced**

2. When the bar magnet begins to move inside the coil, there is a reading on the voltmeter

- As the bar magnet moves, its magnetic field lines 'cut through' the coil, generating a **change in magnetic flux ($\Delta\Phi$)**
- This induces an **e.m.f** within the coil, shown momentarily by the reading on the voltmeter

3. When the bar magnet is taken back out of the coil, an e.m.f is induced in the opposite direction

- As the magnet changes direction, the direction of the current changes
- The voltmeter will momentarily show a reading with the opposite sign

4. Increasing the speed of the magnet induces an e.m.f with a higher magnitude

- As the speed of the magnet increases, the rate of change of flux increases



Your notes

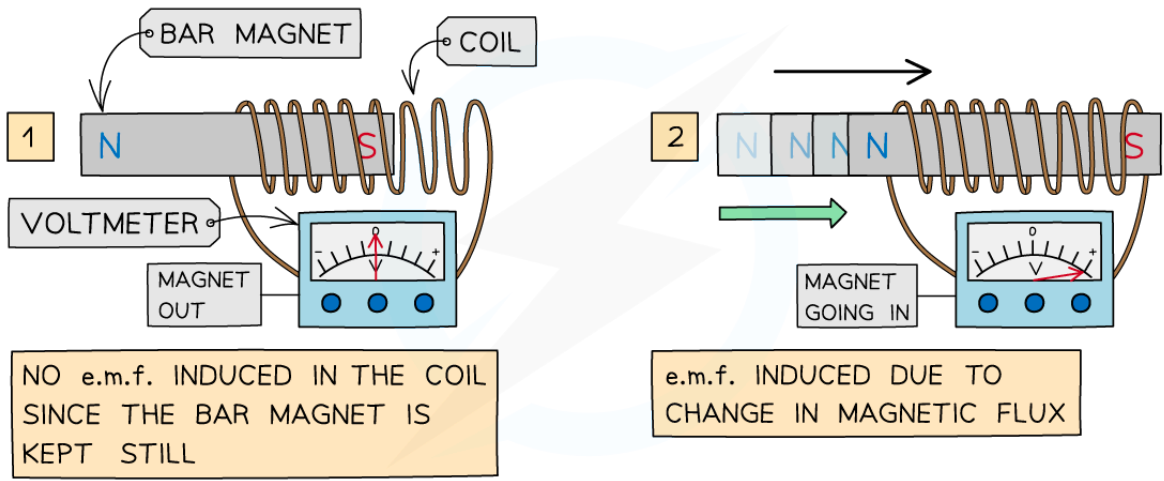

Copyright © Save My Exams. All Rights Reserved

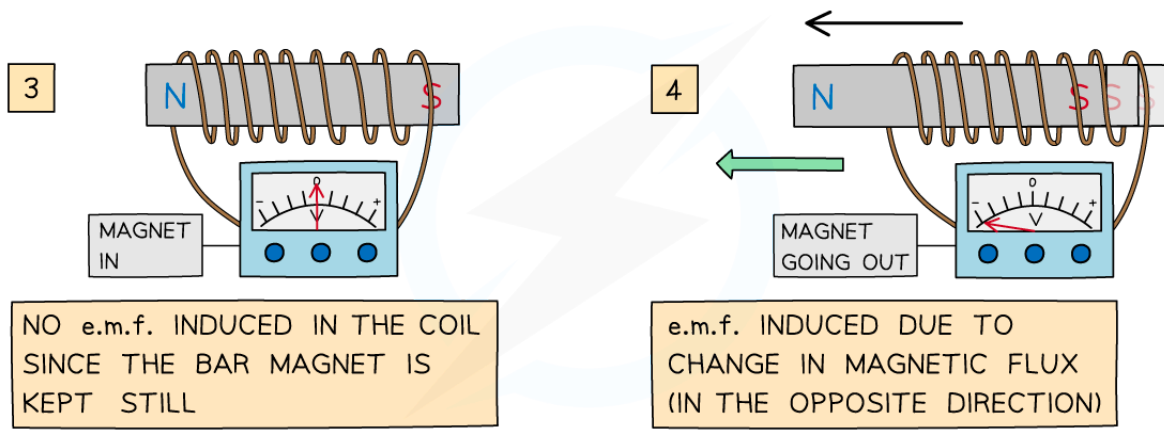

Copyright © Save My Exams. All Rights Reserved

An e.m.f is induced only when the bar magnet is moving through the coil

- Factors that will **increase** the magnitude of the induced e.m.f are:
 - Moving the magnet **faster** through the coil
 - Adding more **turns** to the coil
 - Increasing the **strength** of the bar magnet

Experiment 2: Moving a wire through a magnetic field

- When a long wire is connected to a voltmeter and moved between two magnets, an e.m.f is induced
 - **Note:** there is no current flowing through the wire to start with

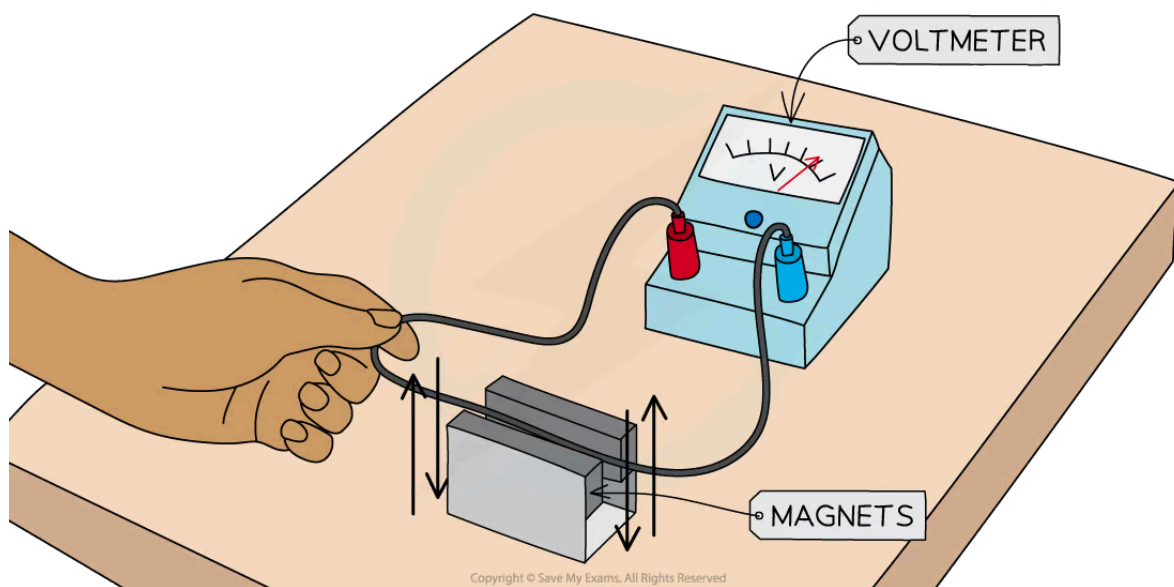

A wire is moved between two magnets connected to a voltmeter to induce an e.m.f

The expected results are...

1. When the wire is not moving, the voltmeter shows a zero reading

- When the wire is held still inside, or outside, the magnets the rate of change of flux is zero so there is **no e.m.f induced**

2. As the wire moves between the magnets, an e.m.f is induced within the wire

- This is shown momentarily by the reading on the voltmeter
- As the wire moves through the magnetic field, it 'cuts through' the magnetic field lines, generating a **change in magnetic flux**

3. When the wire is moved back out of the field, an e.m.f is induced in the opposite direction

- As the wire changes direction, the direction of the current changes
- The voltmeter will momentarily show a reading with the opposite sign
- Factors that will increase the magnitude of the induced e.m.f are:
 - Increasing the **length** of the wire
 - Moving the wire between the magnets **faster**
 - Increasing the **strength** of the magnets



Your notes

Magnetic Flux (HL)

Emf, Magnetic Flux & Magnetic Flux Linkage

- Magnetic flux is a quantity which signifies how much of a magnetic field passes **perpendicularly** through an area
- It is defined as:
The product of the magnetic flux density and the cross-sectional area perpendicular to the direction of the magnetic flux density

- Magnetic flux when the field and motion are at 90° can be calculated using the simple equation:

$$\Phi = BA$$

- Where:
 - Φ = magnetic flux (Wb)
 - B = magnetic flux density (T)
 - A = cross-sectional area (m^2)
- it is defined by the symbol Φ (greek letter 'phi') and measured in units of **Webers** (Wb)

How does magnetic flux change with angle?

- Since the flux is the total magnetic field that passes through a given **area**
 - It is a maximum when the magnetic field lines are **perpendicular** to the plane of the area
 - It is zero when the magnetic field lines are **parallel** to the plane of the area
- For a coil, the amount of magnetic flux varies as the coil rotates within the field

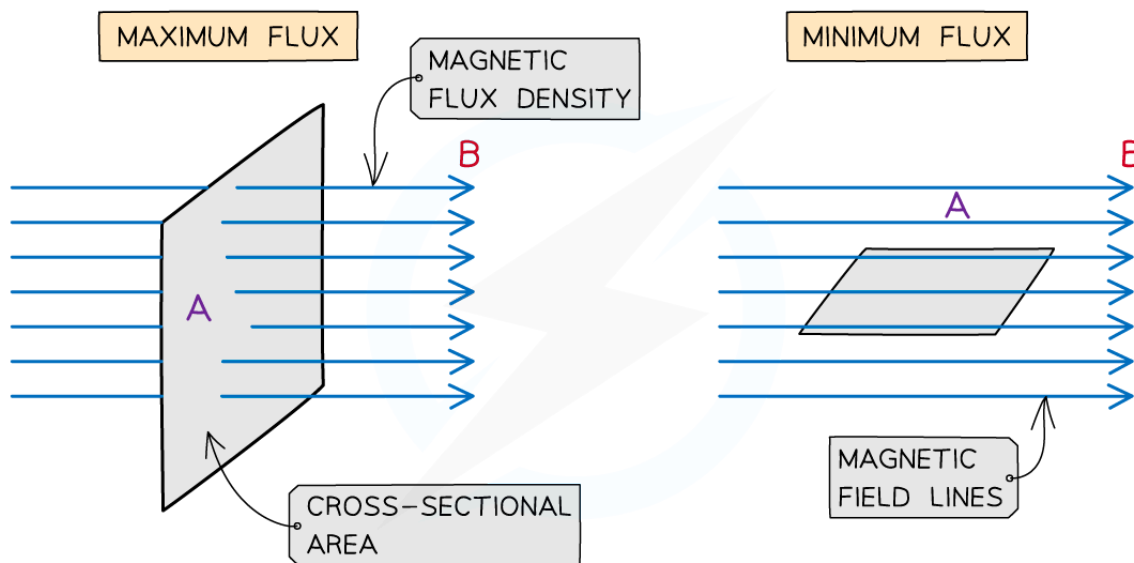

Copyright © Save My Exams. All Rights Reserved



Your notes

The magnetic flux is maximum when the magnetic field lines and the area they are travelling through are perpendicular

- In other words, magnetic flux is the **number of magnetic field lines through a given area**
- When the magnetic field lines are **not** completely perpendicular to the area A , then the **component** of magnetic flux density B is **perpendicular** to the area is taken
- The equation then becomes:

$$\Phi = BA \cos(\theta)$$

- Where:
 - Φ = magnetic flux (Wb)
 - B = magnetic flux density (T)
 - A = cross-sectional area (m^2)
 - θ = angle between magnetic field lines and the line perpendicular to the plane of the area (often called the normal line) (degrees)

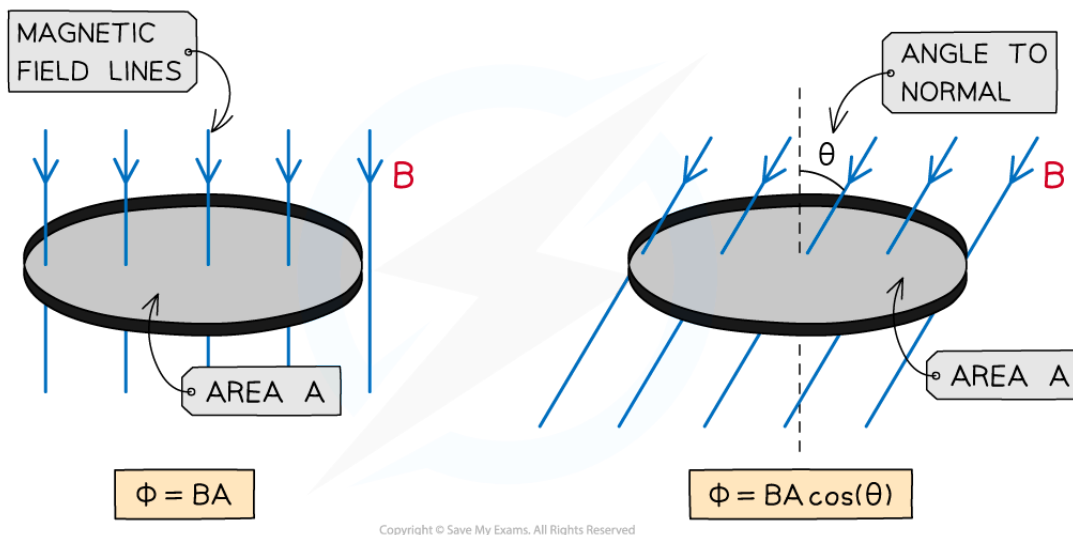

The magnetic flux increases as the angle between the field lines and plane decreases

- This means the magnetic flux is:
 - **Maximum** = BA when $\cos(\theta) = 1$ therefore $\theta = 0^\circ$. The magnetic field lines are perpendicular to the plane of the area
 - **Minimum** = 0 when $\cos(\theta) = 0$ therefore $\theta = 90^\circ$. The magnetic field lines are parallel to the plane of the area

Magnetic Flux Linkage

- More coils in a wire mean a **larger** e.m.f is induced
- The **magnetic flux linkage** is a quantity commonly used for solenoids which are made of N turns of wire
- The flux linkage is defined as:



Your notes

The product of the magnetic flux and the number of turns of the coil

- It is calculated using the equation:

$$\text{Magnetic flux linkage} = \Phi N = BAN$$

- Where:

- Φ = magnetic flux (Wb)
- N = number of turns of the coil
- B = magnetic flux density (T)
- A = cross-sectional area (m^2)

- The flux linkage ΦN has the units of **Weber turns (Wb turns)**

- An e.m.f is induced in a circuit when the magnetic flux linkage changes with respect to time

- This means an e.m.f is induced when there is:

- A changing magnetic flux density B
- A changing cross-sectional area A
- A change in angle θ

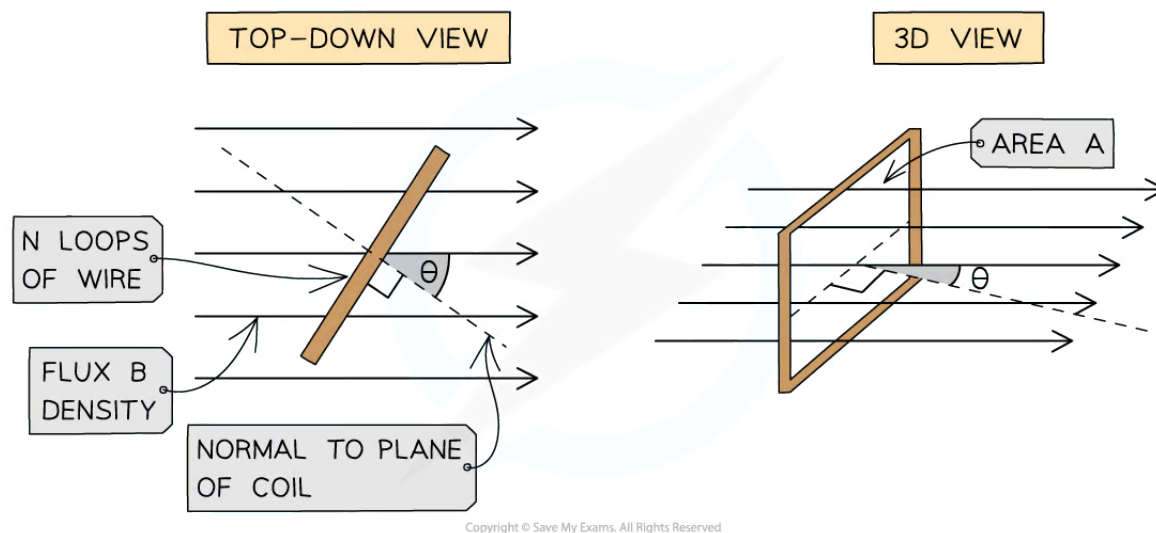

The magnetic flux through a rectangular coil increases as the angle between the field lines and plane decreases

- Magnetic flux linkage also **changes** with the rotation of the coil
 - It is at a **maximum** when the field lines are **perpendicular** to the plane of the area they are passing through
 - This is the same pattern as the magnetic flux
- Therefore, the component of the flux density which is perpendicular is equal to:

$$\Phi N = BAN \cos(\theta)$$

- Where:
 - N = number of turns of the coil



Your notes



Your notes

Worked example

An aluminium window frame has width of 40 cm and length of 73 cm.

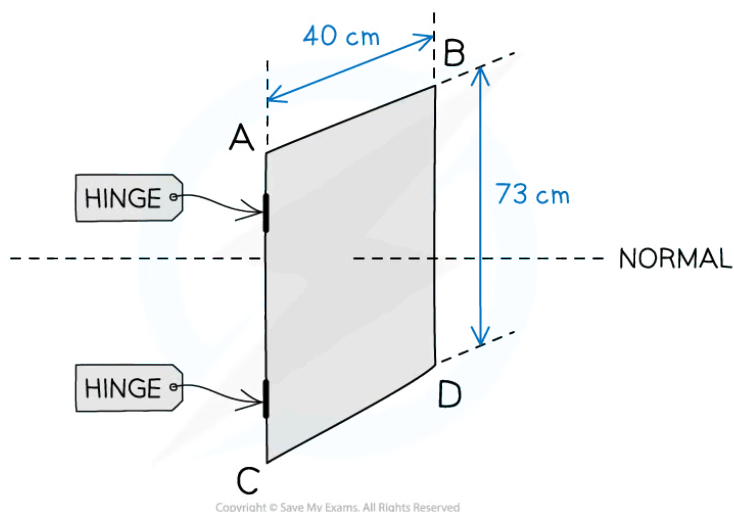

The frame is hinged along the vertical edge AC. When the window is closed, the frame is normal to the Earth's magnetic field with magnetic flux density $1.8 \times 10^{-5} \text{ T}$.

- Calculate the magnetic flux through the window when it is closed.
- Sketch the graph of the magnetic flux against angle between the field lines and the normal when the window is opened and rotated by 180° .

Answer:

(a)

Step 1: Write out the known quantities

- Cross-sectional area, $A = 40 \text{ cm} \times 73 \text{ cm} = (40 \times 10^{-2}) \times (73 \times 10^{-2}) = 0.292 \text{ m}^2$
- Magnetic flux density, $B = 1.8 \times 10^{-5} \text{ T}$

Step 2: Write down the equation for magnetic flux

$$\Phi = BA$$

Step 3: Substitute in values

$$\Phi = (1.8 \times 10^{-5}) \times 0.292 = 5.256 \times 10^{-6} = 5.3 \times 10^{-6} \text{ Wb}$$

(b)

- The magnetic flux will be at a **minimum** when the window is opened by 90° and a **maximum** when fully closed or opened to 180°

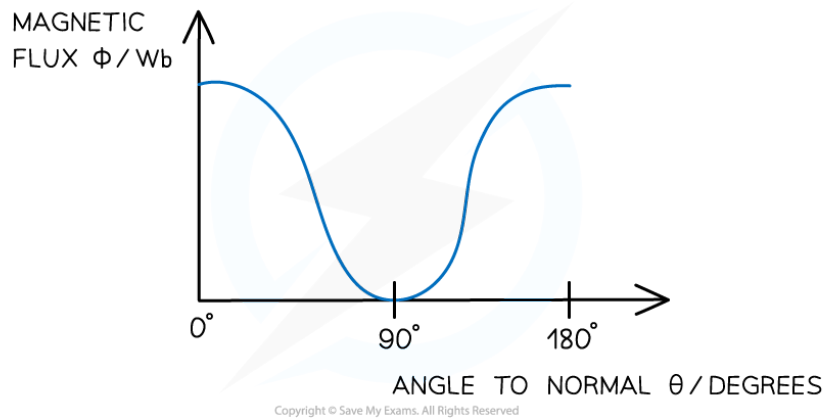

Your notes

Examiner Tip

Watch out for area given in cm^2 or mm^2 . For the magnetic flux to be in Webers, the flux density needs to be Tesla and the area in m^2 .

This area may not always be a square, but a circle as well. The areas of common 2D shapes are given in your data booklet.



Your notes

Faraday's Law of Induction (HL)

Faraday's Law of Induction

- Faraday's Law connects the **rate** of change of magnetic flux linkage with induced e.m.f
- It is defined in words as:

The magnitude of an induced e.m.f is directly proportional to the rate of change of magnetic flux linkage

- Faraday's Law of induction is defined by the equation:

$$\mathcal{E} = \frac{N(\Delta \Phi)}{\Delta t}$$

- Where:
 - \mathcal{E} = induced e.m.f (V)
 - $N\Delta(\Phi)$ = change in magnetic flux linkage (Wb turns)
 - Δt = time interval (s)
- When a coil is completely vertical relative to the magnetic field lines:
 - The change in magnetic flux linkage is at a **maximum** - the field lines are travelling through the area of the coil
 - There is **no e.m.f** induced - there is no cutting of field lines i.e. there is no change in magnetic flux linkage
- When a coil is completely horizontal relative to the magnetic field lines:
 - The change in magnetic flux linkage is **zero** - there are no field lines travelling through the area of the coil
 - Maximum e.m.f** is induced - there is the maximum cutting of field lines



Your notes

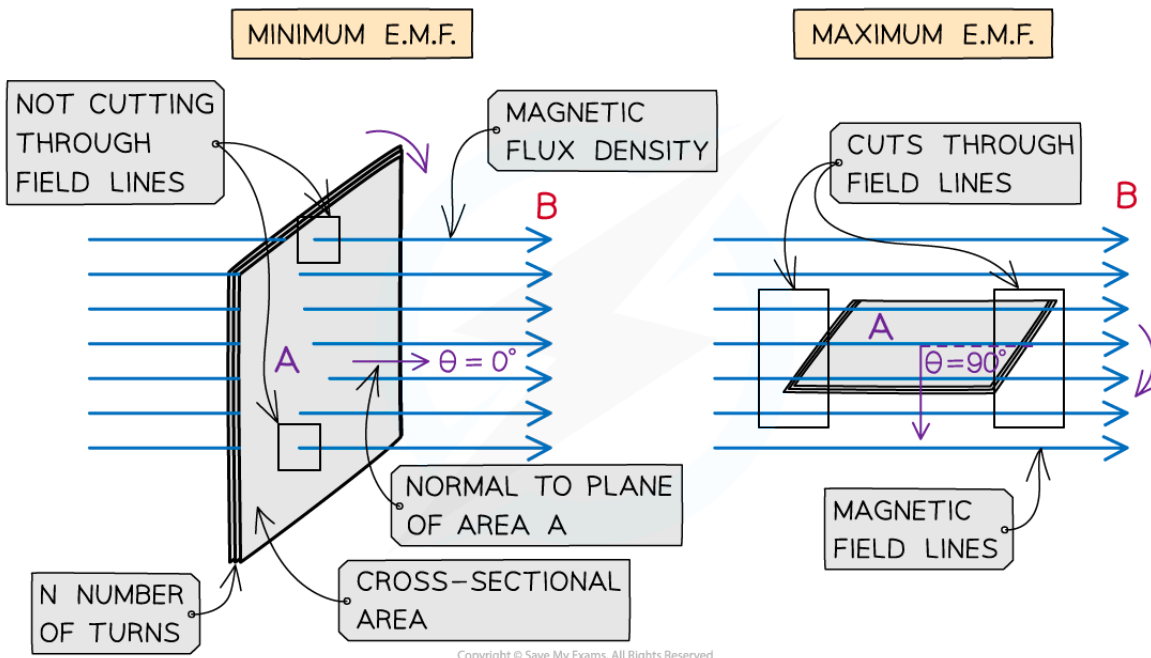

Emf induced and the rotation of a coil



Your notes

Worked example

A small rectangular coil contains 350 turns of wire. The longer sides are 3.5 cm and the shorter sides are 1.4 cm.

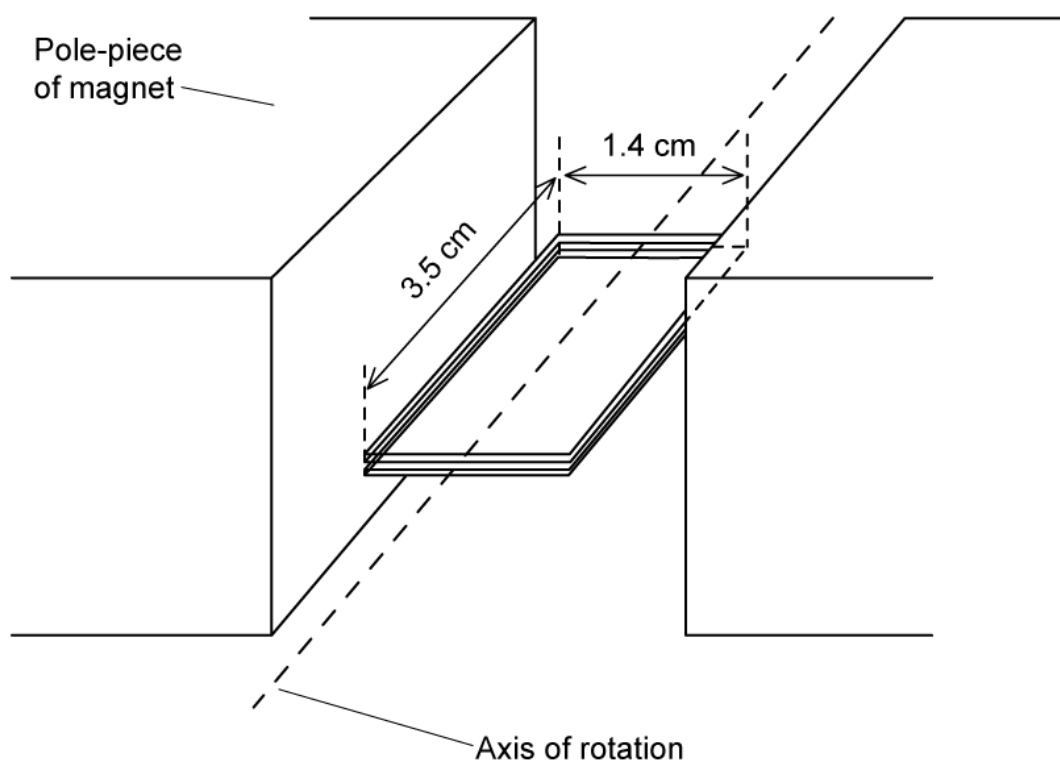

The coil is held between the poles of a large magnet so that the coil can rotate about an axis through its centre. The magnet produces a uniform magnetic field of flux density 80 mT between its poles.

The coil is positioned horizontally and then turned through an angle of 40° over a time interval of 0.18 s.

Calculate the magnitude of the average e.m.f induced in the coil.

Answer:

Step 1: Write down the known quantities

- Magnetic flux density, $B = 80 \text{ mT} = 80 \times 10^{-3} \text{ T}$
- Area, $A = 3.5 \times 1.4 = (3.5 \times 10^{-2}) \times (1.4 \times 10^{-2}) = 4.9 \times 10^{-4} \text{ m}^2$
- Number of turns, $N = 350$
- Angle of rotation, $\theta = 40^\circ$
- Time interval, $\Delta t = 0.18 \text{ s}$

Step 2: Write down the equation for Faraday's law:



$$\varepsilon = \frac{N(\Delta \Phi)}{\Delta t}$$

Step 3: Write out the equation for the change in flux linkage:

- The number of turns N and the coil area A stay constant
- The flux through the coil changes as $B \cos \theta$ as it rotates
- Therefore, the equation to use is:

$$N(\Delta \Phi) = NBA \cos \theta$$

Step 4: Determine the change in magnetic flux linkage

- The coil is initially horizontal ($\theta = 0^\circ$) in the field and is rotated by 40°
- The **initial** flux linkage through the coil is:

$$N\Phi_{initial} = NBA \cos 0^\circ = 350 \times (80 \times 10^{-3}) \times (4.9 \times 10^{-4}) \times 1$$

$$N\Phi_{initial} = 0.01372 \text{ Wb}$$

- The **final** flux linkage through the coil is:

$$N\Phi_{final} = NBA \cos 40^\circ = 350 \times (80 \times 10^{-3}) \times (4.9 \times 10^{-4}) \times \cos 40$$

$$N\Phi_{final} = 0.01051 \text{ Wb}$$

- Therefore, the change in flux linkage is:

$$N\Delta \Phi = N\Phi_{initial} - N\Phi_{final}$$

$$N\Delta \Phi = 0.01372 - 0.01051 = 3.21 \times 10^{-3} \text{ Wb}$$

Step 5: Substitute the change in flux linkage and time into Faraday's law equation:

$$\varepsilon = \frac{3.21 \times 10^{-3}}{0.18} = 0.0178 \text{ V} = 17.8 \text{ mV}$$

 **Examiner Tip**

The important point to notice is that an emf is induced in a conductor in a magnetic field if there is **change** in flux linkage. This means, the conductor (e.g. a coil) must **cut through** the field lines to have an emf (and hence a current) induced.



Your notes

Lenz's Law (HL)

Lenz's Law

- Lenz's Law is used to predict the **direction** of an induced e.m.f in a coil or wire
 - It is a consequence of the principle of conservation of energy
- Lenz's Law is summarised below:

The induced e.m.f is such that it will oppose the change causing it

- Lenz's law combined with Faraday's law is given by the equation:

$$\varepsilon = -N \frac{\Delta \Phi}{\Delta t}$$

- This equation shows:
 - When a bar magnet goes through a coil, an e.m.f is induced within the coil due to a change in magnetic flux
 - A current is also induced which means the coil now has its own magnetic field
 - The coil's magnetic field acts in the **opposite direction** to the magnetic field of the bar magnet (shown by the minus sign)
- If a direct current (d.c) power supply is replaced with an alternating current (a.c) supply, the e.m.f induced will also be alternating with the same frequency as the supply

Experimental Evidence for Lenz's Law

- To verify Lenz's Law, the only apparatus needed is:
 - A bar magnet
 - A coil of wire
 - A sensitive ammeter
- Note: a cell is **not** required

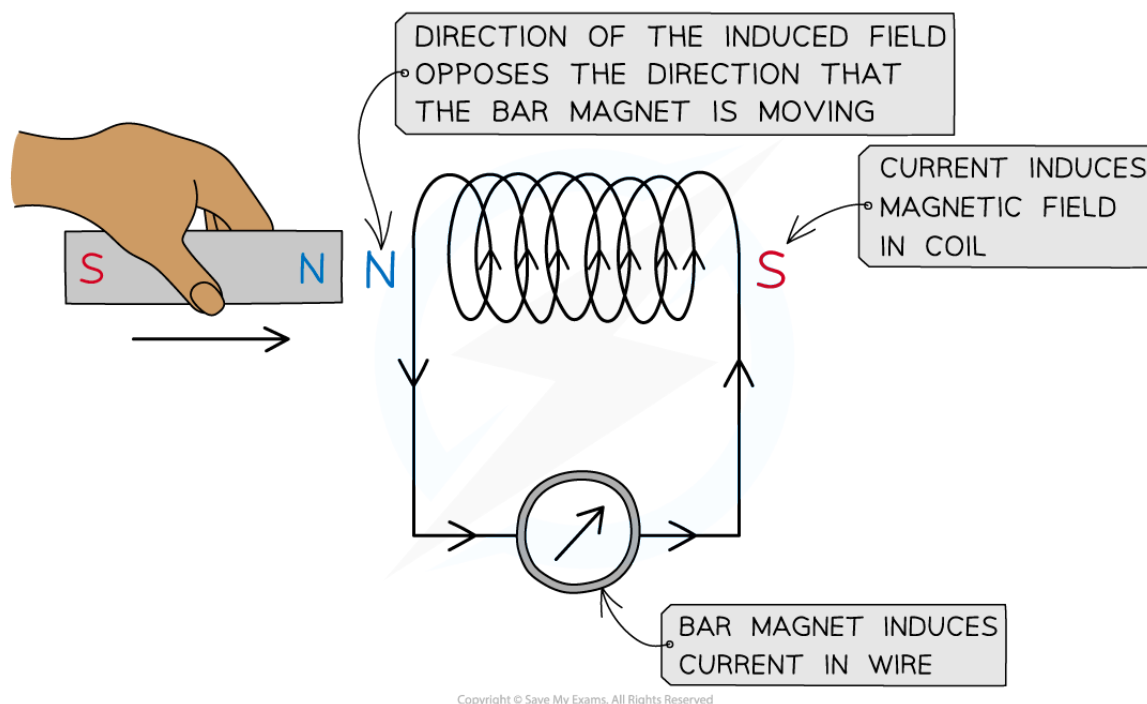

Lenz's law can be verified using a coil connected in series with a sensitive ammeter and a bar magnet

- A known pole (either north or south) of a bar magnet is pushed into the coil
 - This induces an e.m.f in the coil
 - The induced e.m.f drives a current (because it is a complete circuit)
- Lenz's Law dictates:
 - The direction of the e.m.f, and hence the current, must be set up to **oppose** the incoming magnet
 - Since a **north pole** approaches the coil face, the e.m.f must be set up to create an induced **north pole**
 - This is because the two north poles will **repel** each other
- The direction of the current is therefore as shown in the image above
 - The direction of the current can be verified using the right-hand grip rule
 - Fingers curl around the coil in the direction of current and the thumb points along the direction of the flux lines, from **north to south**
 - Therefore, the **current** flows in an **anti-clockwise** direction in the image shown, in order to induce a north pole opposing the incoming magnet

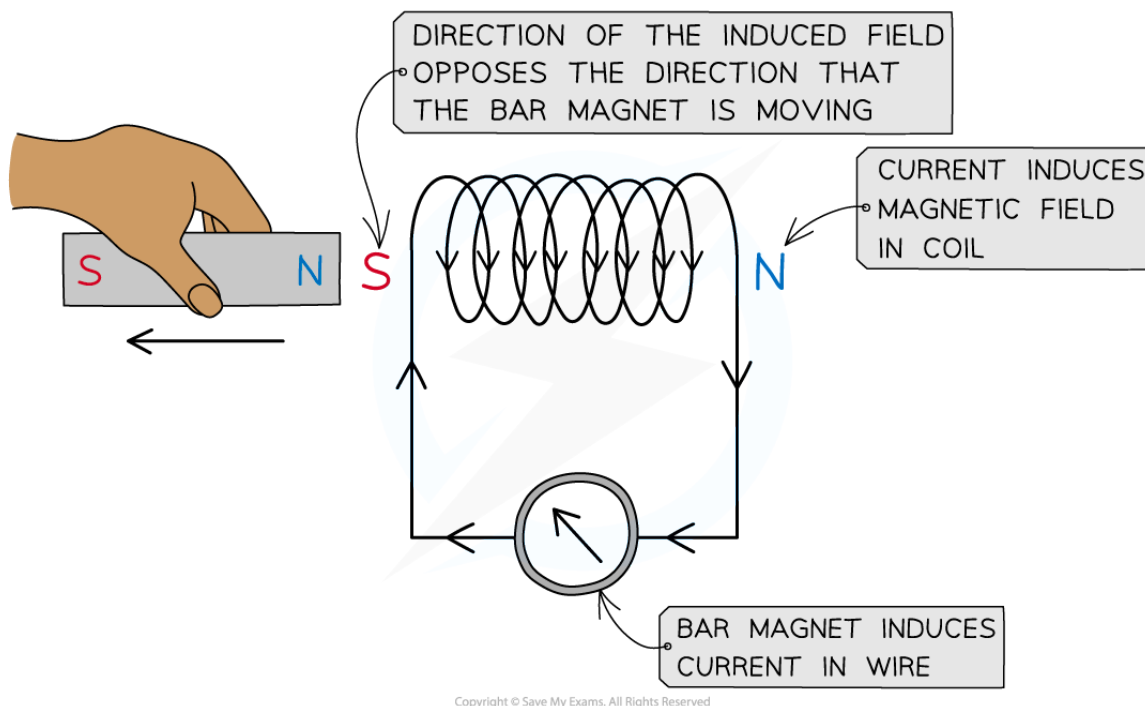

- **Reversing** the magnet direction would give an **opposite** deflection on the voltmeter
 - Lenz's Law would then predict a **south** pole induced at the coil entrance (next to the bar magnet)
 - This would create a north pole at the exist, **attracting** the bar's south pole attempting to leave
 - Therefore, the induced e.m.f **always** produces effects to **oppose** the changes causing it
- This means:
 - The coil will try and **push** the bar magnet to stop it from entering
 - The coil will try and **pull** the bar magnet to stop it from leaving
 - This means the poles of the coil **swaps around** as the bar magnet travels through
- Lenz's Law is a direct consequence of the **principle of conservation of energy**
 - Electromagnetic effects will not create electrical energy out of nothing
 - In order to induce and sustain an e.m.f, for instance, **work** must be done in order to overcome the repulsive effect due to Lenz's Law



Your notes

 **Worked example**

Two conducting loops, X and Y, are positioned so that their planes are parallel and their centres sit on the same line, as shown in the diagram.

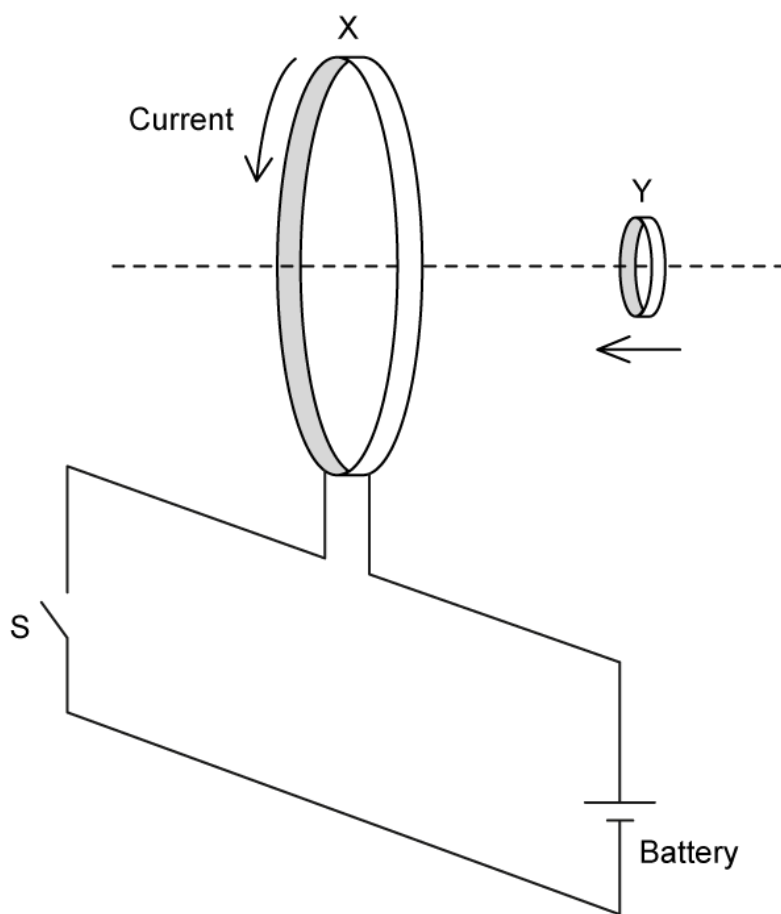

When the switch S is closed, a constant counterclockwise current flows in X. Loop X is stationary and loop Y is moved towards X at a constant speed.

State and explain:

- (a) how the magnetic flux in loop Y varies with time.
- (b) how the size and direction of the induced current in loop Y varies with time.

Work must be done on loop Y to maintain its constant speed towards X

- (c) Explain why.



Your notes

Answer:

(a) Variation of magnetic flux in Y:

- As Y approaches X, it cuts an increasing number of magnetic field lines
- Therefore, the magnetic flux in Y **increases** as it approaches X

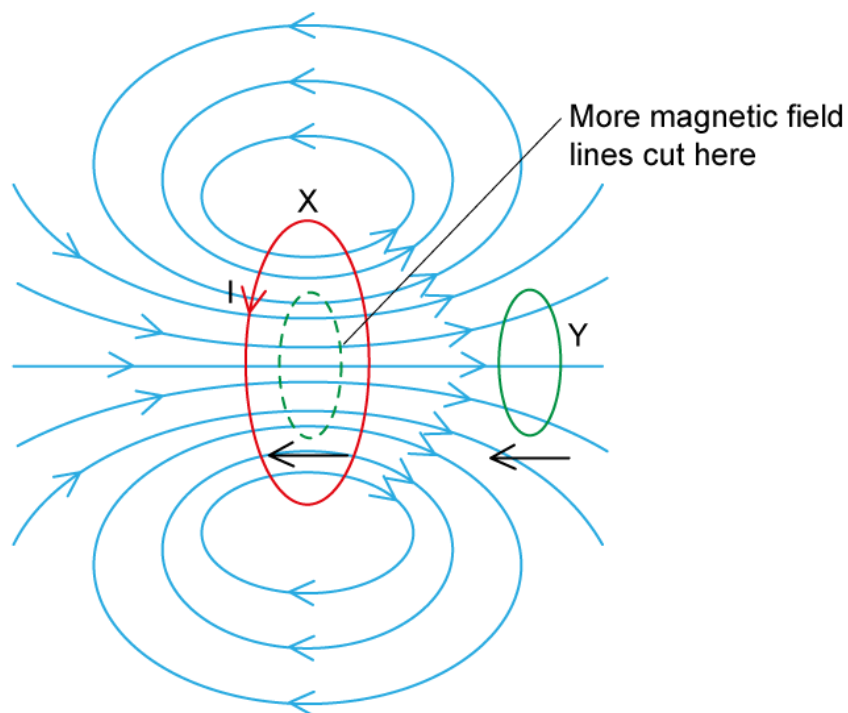

(b) Direction of the induced current in Y:

- Lenz's law states that the induced e.m.f will be such that it will oppose the change producing it
- Hence, the induced current in Y will flow in a constant **clockwise** direction

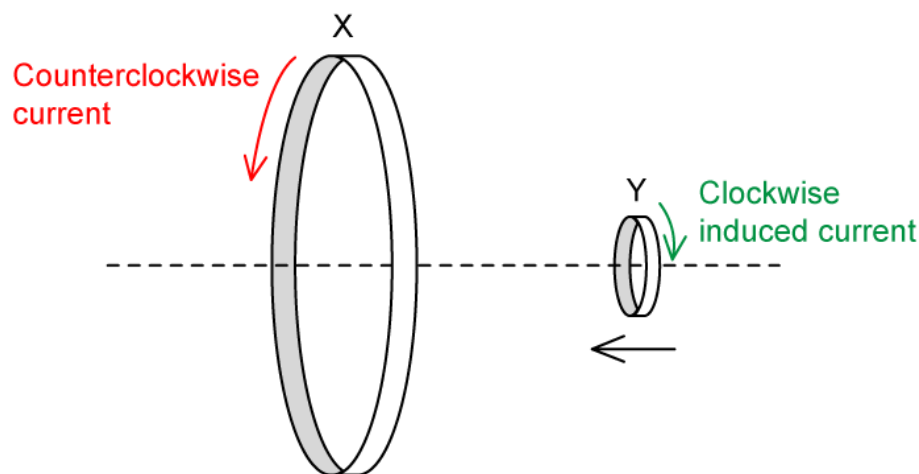

Size of the induced current in Y:

- Faraday's law states that the induced e.m.f. increases with the rate of change of flux linkage
- The rate of change of magnetic flux in Y increases as it approaches X
- Potential difference and current are related by $V = IR$
- The resistance of the loop is constant, hence, the size of the induced current in Y will **increase** with time

(c) Why work must be done to maintain a constant speed:

- The current induced in Y produces a magnetic field opposing that of X
- So, according to Lenz's law, there will be a magnetic force opposing the motion of Y
- Hence, work must be done on Y to **overcome** this opposing force

Examiner Tip

You should remember that the negative sign is representative of **Lenz's Law** (without out it, it is just **Faraday's Law**) which says that the induced e.m.f ϵ is set up **to oppose the change causing it**. The negative sign indicates motion in an opposing direction. This is the form of the equation given on your data booklet.

Self Induction & Mutual Induction

- When changes in current within a circuit occur, particularly when the current is alternating at high frequencies, changes in magnetic flux will also occur
- Two types of induction can be observed
 - Self-induction** - induction within the **same** circuit
 - Mutual induction** - induction **between** circuits
- These both occur as a consequence of **Lenz's law**

Self Induction

- When induction occurs within the same circuit, this is known as self-induction
- Self-induction is defined as

The effect in which a change in the current tends to produce an induced emf which opposes the change of current in the same circuit
- The induced current is produced by a **back e.m.f.** i.e. an induced e.m.f. that opposes a change of current (in the same circuit)
 - Note: this is the same induced e.m.f. as described by Lenz's law

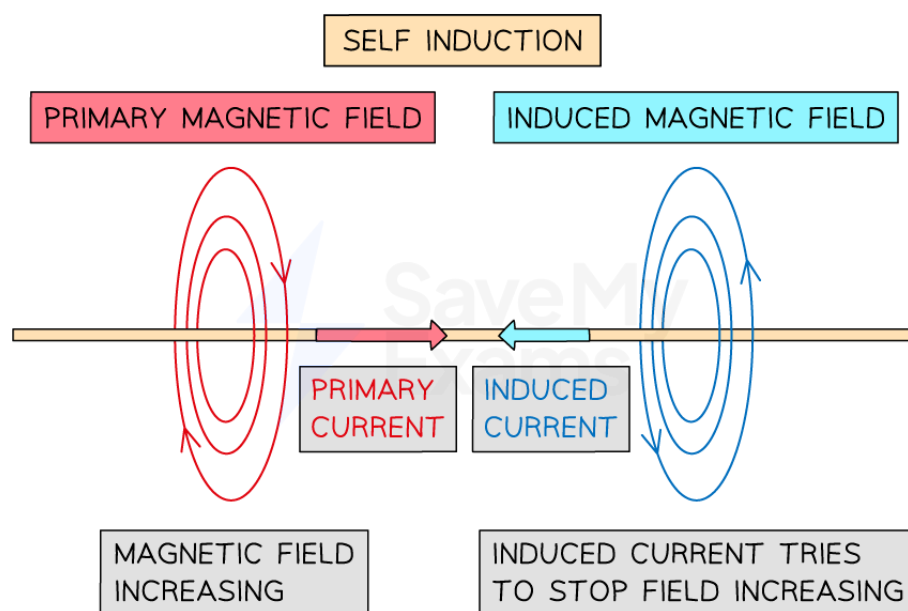

Copyright © Save My Exams. All Rights Reserved

Self-induction occurs within the same circuit. The primary magnetic field induces a current which opposes the primary current.

- The back e.m.f. is proportional to minus the rate of current change

$$\text{back e.m.f.} \propto - \frac{\Delta I}{\Delta t}$$



Your notes

Mutual Induction

- When induction occurs in a separate circuit from the one producing the change, this is known as mutual induction
- Mutual induction is defined as

The effect in which a change in the current in one circuit tends to produce an induced emf which opposes the change of current in a neighbouring circuit
- An important application of mutual induction is **transformers**

Transformers

- A transformer is

A device that changes high alternating voltage at low current to low alternating voltage at high current, and vice versa
- A transformer is designed to reduce heat energy loss whilst transmitting electricity through power lines from power stations to the national grid
- A transformer is made up of:
 - A primary coil
 - A secondary coil
 - An iron core

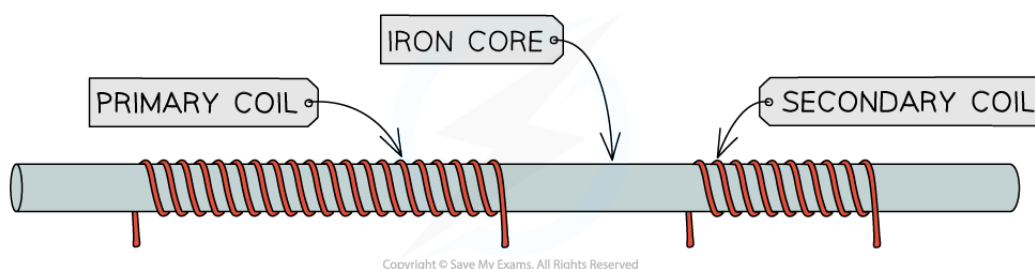

Components of a transformer

- The primary and secondary coils are wound around the **soft iron core**
 - The soft iron core is necessary because it enhances the strength of the magnetic field from the primary to the secondary coil
 - Soft iron is used because it can easily be magnetised and demagnetised

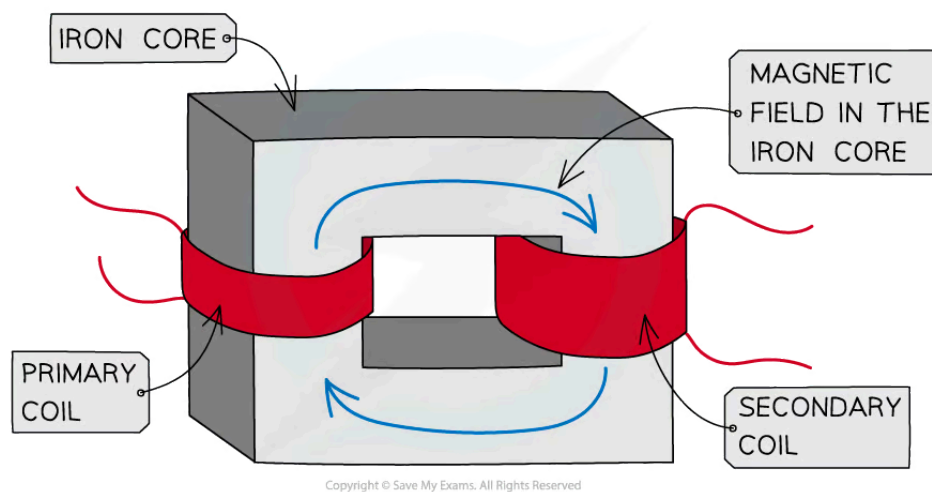

A step-up transformer has more turns in the secondary coil than primary

- In the primary coil, an alternating current producing an alternating voltage is applied
 - This creates an **alternating magnetic field** inside the iron core and therefore a changing magnetic flux linkage
- A changing magnetic field passes through to the secondary coil through the iron core
 - This results in a changing magnetic flux linkage in the secondary coil and from Faraday's Law, an **e.m.f is induced**
- An e.m.f produces an alternating output voltage from the secondary coil
 - The output alternating voltage is at the **same** frequency as the input voltage
- In a **step-up** transformer
 - The secondary coil has **more turns** than the primary coil
 - Hence, the secondary voltage is **larger** than the primary voltage
- In a **step-down** transformer
 - The primary coil has **more turns** than the secondary coil
 - Hence, the primary voltage is **larger** than the secondary voltage

 **Examiner Tip**

You don't need to remember the equation for back e.m.f, but you must be clear on self and mutual induction and the differences between them.



Your notes

AC Generators (HL)

The AC generator

- If a coil of wire is rotated inside a magnetic field by an external force, an e.m.f. will be generated in the wire which causes current to flow within the coil
- A simple A.C. generator converts mechanical energy into electrical energy in the form of alternating current

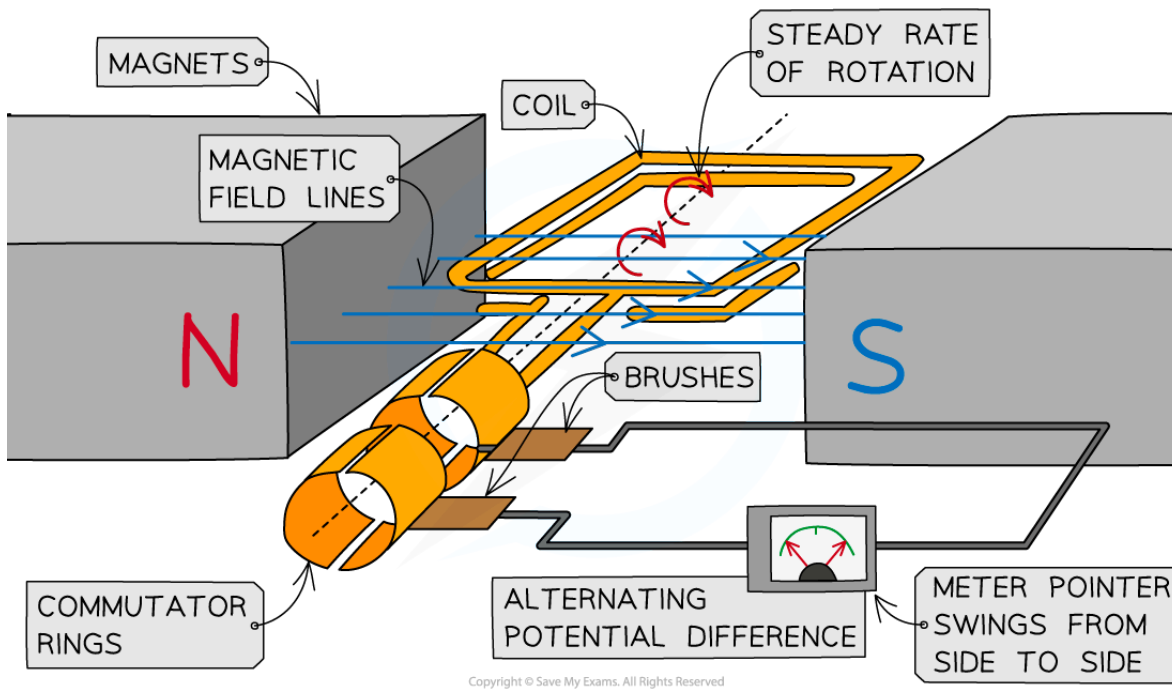

An alternator is a rotating coil in a magnetic field connected to commutator rings

- A rectangular coil is forced to spin in a **uniform magnetic field**
- The coil is connected to a centre-reading meter by **metal brushes** that press on two metal **slip rings** (or commutator rings)
 - The slip rings and brushes provide a continuous connection between the coil and the meter
- When the coil turns in one direction:
 - The pointer deflects first one way, then the opposite way, and then back again
 - This is because the coil **cuts through** the magnetic field lines and a **potential difference**, and therefore current, is **induced** in the coil
- The pointer deflects in both directions because the current in the circuit repeatedly **changes direction** as the coil spins
 - This is because the induced potential difference in the coil repeatedly changes its direction
 - This continues as long as the coil keeps turning in the **same** direction
- The induced potential difference and the current **alternate** because they repeatedly **change direction**



Your notes

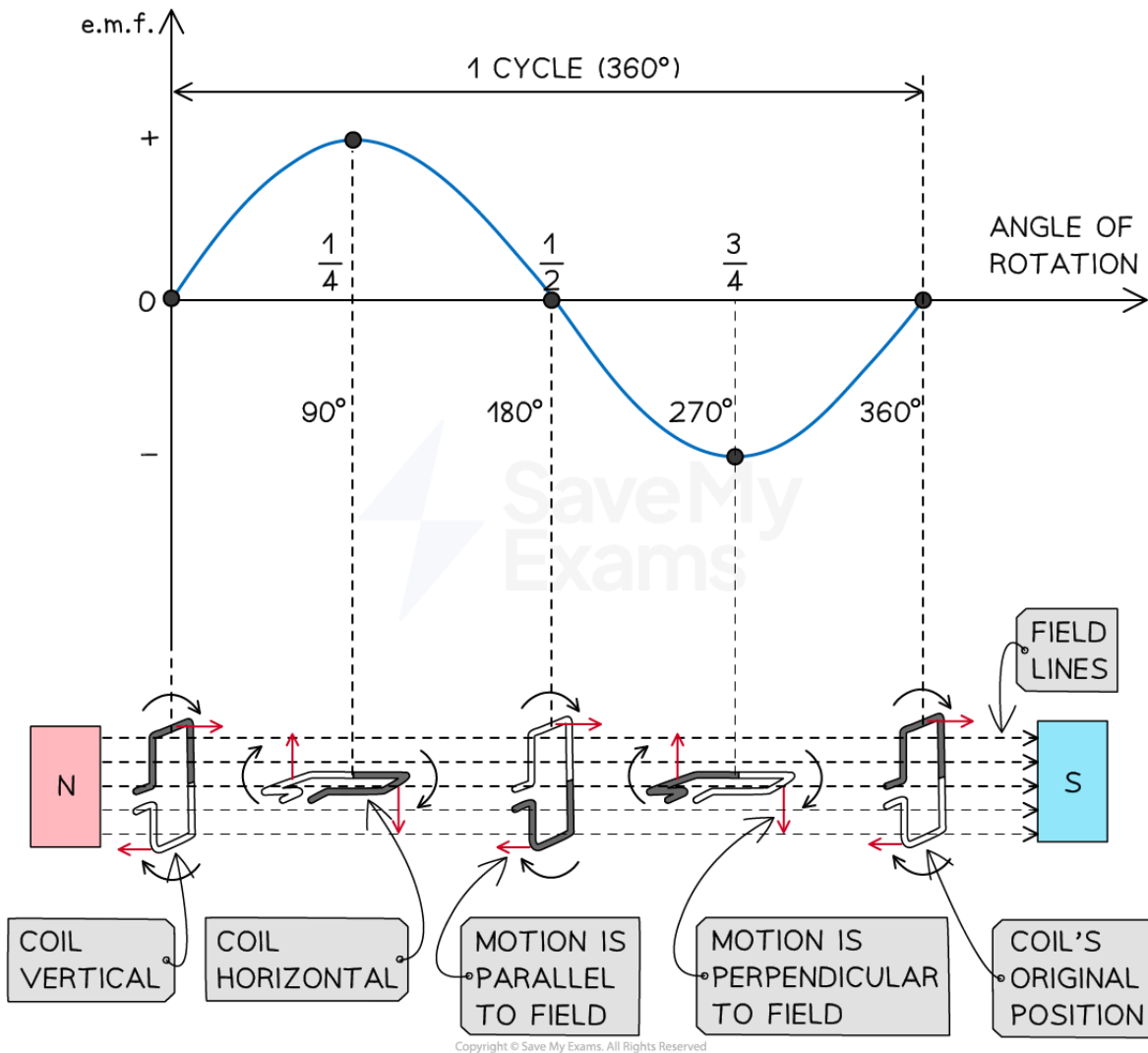

As the coil rotates in the magnetic field, the changing magnetic flux causes the induction of e.m.f. in the opposite sides of the coil

Emf Induction in a Rotating Coil

- When a coil rotates in a uniform magnetic field, the flux through the coil will vary as it rotates
- Since e.m.f is the rate of change of flux linkage, this means the e.m.f will also change as it rotates
 - The maximum e.m.f is when the coil **cuts through** the most field lines
 - The e.m.f induced is an **alternating** voltage
- Flux linkage is given by

$$N\Phi = BAN \cos \theta$$

- Angular speed ω is defined as the rate of change of angular displacement, so

$$\omega = \frac{\theta}{t}$$

- Therefore, for a rotating coil, the angle θ depends on the angular speed of the coil ω :

$$\theta = \omega t$$

- Hence, flux linkage can also be written as:

$$N\Phi = BAN \cos \omega t$$

- Where:

- $N\Phi$ = flux linkage (Wb turns)
- B = magnetic flux density (T)
- A = cross-sectional area of the coil (m^2)
- N = number of turns of coil
- ω = angular speed of the coil (rad s^{-1})
- t = time (s)



Your notes



Your notes

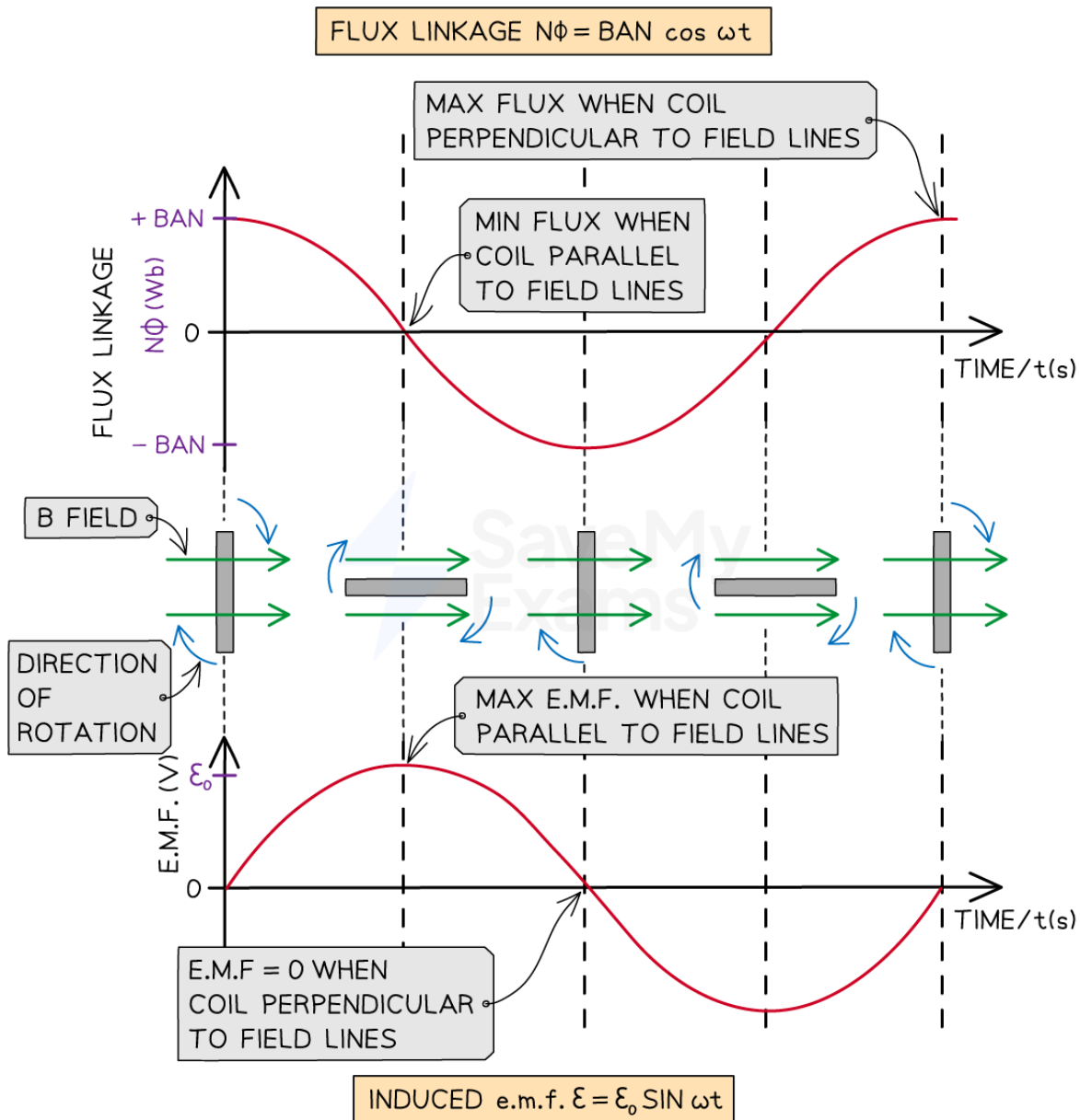

Flux linkage and induced e.m.f. in a rotating coil

- The graph shows that
 - The induced e.m.f varies sinusoidally and it is 90° out of phase with the flux linkage
- Mathematically, the induced e.m.f. can also be written as:

$$\varepsilon = \varepsilon_0 \sin \omega t$$

$$\varepsilon = BAN\omega \sin \omega t$$

- Where:
 - ε = e.m.f induced in the coil (V)
 - ε_0 = maximum e.m.f induced in the coil (V)
- The size of the induced e.m.f. in a rotating coil can be increased by **increasing the frequency of rotation of the coil**
- Increasing the coil's frequency of rotation increases:
 - The **frequency** of the alternating voltage
 - The **amplitude** of the alternating voltage

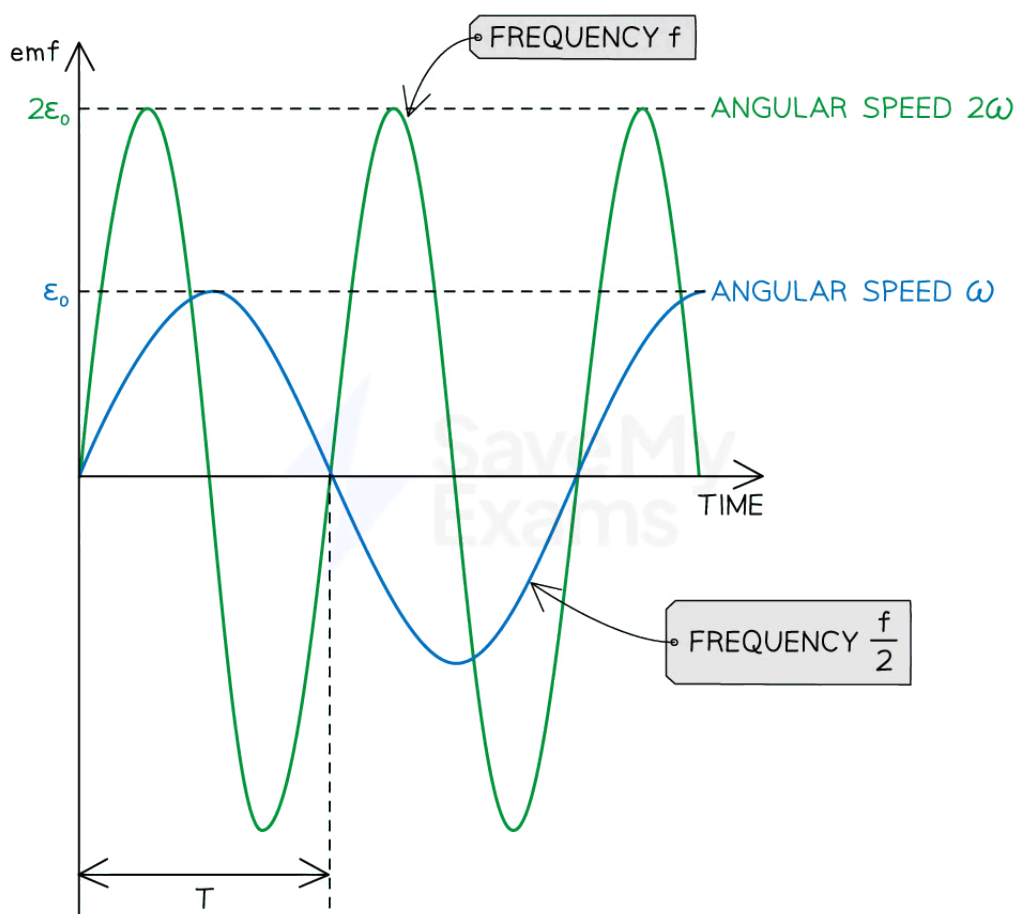

Copyright © Save My Exams. All Rights Reserved

Doubling the angular speed of the rotating coil in a magnetic field doubles the size of the induced e.m.f. (double the amplitude) and the frequency of the rotation (half the time period)



Your notes

Worked example

An alternating current generator induces an e.m.f. of \mathcal{E} at a frequency f .

The rotational speed of the coil in the generator is doubled.

Which row correctly identifies the new output e.m.f. and the new frequency?

	e.m.f.	frequency
A.	$2\mathcal{E}$	$2f$
B.	$\sqrt{2}\mathcal{E}$	$2f$
C.	$2\mathcal{E}$	$\frac{f}{2}$
D.	$\sqrt{2}\mathcal{E}$	$\frac{f}{2}$

Answer: A

- Angular speed, time period and frequency are related by

$$\omega = \frac{2\pi}{T} = 2\pi f$$

- Therefore, $\omega \propto f$, so if angular speed doubles, the frequency will also double
- If the coil rotates at twice the frequency, the rate of change of magnetic flux linkage will double
- Hence, induced e.m.f. and angular speed are directly proportional $\mathcal{E} \propto \omega$
- This means the induced e.m.f. will double if angular speed doubles

$$\text{new e.m.f.} = 2\mathcal{E}, \text{ new frequency} = 2f$$

Examiner Tip

Remember not to get mixed up with when the e.m.f or the flux linkage is at its maximum:

- When the plane of the coil is **perpendicular** to the field lines
 - The flux linkage is at its **maximum**
 - The e.m.f = **zero**
- When the plane of the coil is **parallel** to the field lines
 - The flux linkage is **zero**
 - The e.m.f is at its **maximum**

Since ω is in units of rads s^{-1} , make sure your calculator is in **radians** mode before entering any values into $\sin(\omega t)$ or $\cos(\omega t)$.

The equation of e.m.f with $\sin(\omega t)$ is **not** given in your data booklet - you must be able to recognise this in exam questions!



Your notes