

Structured Questions

3.1 Thermal Concepts

3.1.1 Solids, Liquids & Gases / 3.1.2 Temperature / 3.1.3 Internal Energy / 3.1.4 Specific Heat Capacity / 3.1.5 Specific Latent Heat / 3.1.6 Phase Change / 3.1.7 Investigating Thermal Energy

Easy (5 questions)	/49
Medium (5 questions)	/56
Hard (5 questions)	/43
Total Marks	/148

Scan here to return to the course
or visit [savemyexams.com](https://www.savemyexams.com)



Easy Questions

1 (a) Define the specific latent heat of fusion of a substance.

(2 marks)

(b) Draw a line to indicate which molecular model of matter matches with which state.

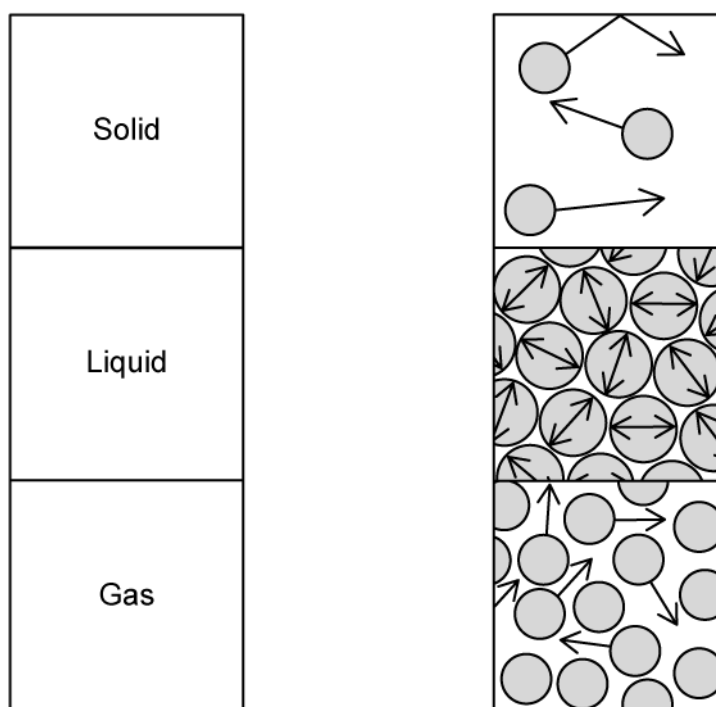

(3 marks)

(c) The following statements are about the molecular model of matter.

The potential energy changes during change of _____.

Potential energy is greater for _____ than for _____ more energy is required to _____ bonds than just _____ them.

Therefore, specific latent heat of _____ is _____ than specific latent heat of _____ for any substance.

Complete the missing gaps using keywords from the list provided.

You may use any keyword once, more than once, or not at all.

- weaken
- fusion
- break
- greater
- vaporisation
- less
- state

(3 marks)

(d) A 2.5 g block of ice is placed into a beaker of water where 825 J of energy is needed to melt the ice completely.

(i) Calculate the specific latent heat of fusion of ice.

[3]

(ii) State an assumption that you have made in your answer to part (i).

[1]

(4 marks)

2 (a) Define specific heat capacity.

(2 marks)

(b) The change in thermal energy, Q is given by the equation:

$$Q = mc\Delta T$$

Define the following variables and state an appropriate unit for each:

- | | | |
|-------|------------|-----|
| (i) | m | [1] |
| (ii) | c | [1] |
| (iii) | ΔT | [1] |

(3 marks)

(c) A hot piece of copper is placed into a container of cold water. After a time, the copper and water reach thermal equilibrium.

Outline how it would be known when the copper and water reach thermal equilibrium.

(1 mark)

(d) The following data are available:

Energy transferred to water = 5.6 kJ

Mass of copper = 0.72 kg

Specific heat capacity of copper = $389 \text{ J kg}^{-1} \text{ K}^{-1}$

Calculate the change in temperature of the copper.

(4 marks)

3 (a) Define internal energy

(2 marks)

(b) The fraction of the internal energy that is due to molecular vibration varies in the different states of matter.

Arrange the following states of matter from highest to lowest fraction of internal energy due to molecular vibration.

Gas	Solid	Liquid
-----	-------	--------

(1 mark)

(c) The heating graph shows the change in temperature against energy supplied for a specific substance.

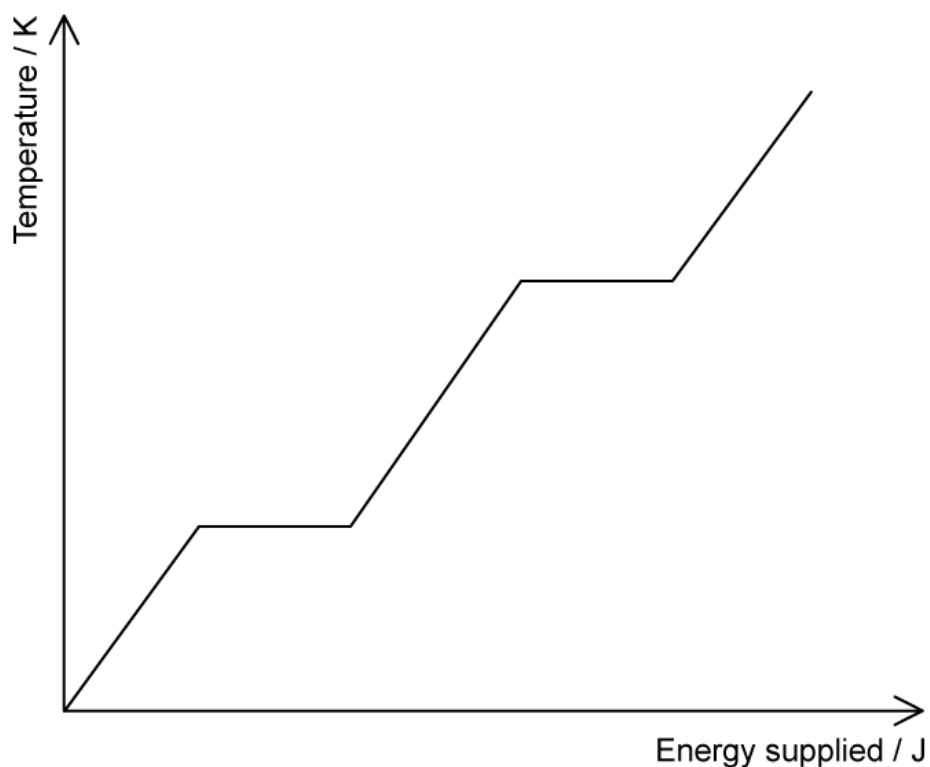

Label the following on the graph:

(i) Solid, liquid and gas

[1]

(ii) Melting and boiling

[1]

(2 marks)

(d) Label on the graph in part (c) the freezing point and the boiling point on the temperature axis.

(2 marks)

4 (a) Define thermal energy.

.....
.....
(1 mark)

An immersion heater is placed in a beaker containing 350 g of water at a temperature of 15 °C. After some time, the temperature of the water is 42 °C. The thermal capacity of the beaker is negligible and the specific heat capacity of water is $4.2 \times 10^3 \text{ J kg}^{-1} \text{ K}^{-1}$.

(b) Estimate the change in internal energy of the water.

.....
.....
.....
.....
(4 marks)

(c) The water is further heated until it starts to boil at constant temperature.

Choose the correct word in the explanation for this scenario:

All the (internal / thermal) energy is used to (separate / fuse) the molecules and not to increase their average (potential / kinetic) energy.

.....
.....
.....
(3 marks)

(d) If water had a higher specific heat capacity, state two differences this would make to boiling water using an immersion heater.

.....
.....
(2 marks)

5 (a) Define the latent heat of vaporisation of a substance.

.....

.....

(2 marks)

(b) Place a tick (✓) next to the correct phase change for using specific latent heat of vaporisation and fusion in the following table.

	Evaporation	Melting	Freezing	Condensation
Latent heat of vaporisation				
Latent heat of fusion				

.....

.....

(2 marks)

(c) The energy required to change the phase of a substance is given by

$$Q = mL$$

Define the following variables and state an appropriate unit for each:

(i) m [1]

(ii) L [1]

.....

.....

(2 marks)

(d) 3400 J of energy is needed to convert 16 g of oxygen from liquid to a gas.

Calculate the latent heat of vaporisation of oxygen.

(4 marks)

Medium Questions

- 1 (a) This question is about modelling the thermal processes involved when a person is exercising.

When cycling, a person generates thermal energy but maintains an approximately constant temperature.

Define thermal energy and temperature and distinguish between the two concepts.

(3 marks)

- (b) The following model may be used to estimate the rise in temperature of a cyclist assuming no thermal energy is lost.

A closed container holds 65 kg of water, which represents the mass of the cyclist. The water is heated at a rate of 2000 W for 20 minutes. This represents the energy generation in the cyclist.

Calculate:

- (i) the thermal energy generated by the heater. [2]
- (ii) the temperature rise of the water, assuming no energy losses. The specific heat capacity of water is $4200 \text{ J kg}^{-1} \text{ K}^{-1}$. [2]

(4 marks)

(c) The temperature rise calculated in (b) would be dangerous to the cyclist.

Outline one mechanism, other than evaporation, by which the container in the model would transfer energy to its surroundings.

(2 marks)

(d) A further process by which energy is lost from the cyclist is the evaporation of sweat.

The percentage of generated energy lost by sweating is 40%. The specific heat of vaporization of sweat is $2.26 \times 10^6 \text{ J kg}^{-1}$.

Using the information above, and your answer to part (b) (i), estimate the mass of sweat evaporated from the cyclist.

(3 marks)

2 (a) This question is about water as it changes state.

Water at constant pressure boils at a constant temperature.

Outline, in terms of the energy of the molecules, the reason for this.

(2 marks)

(b) In an experiment to measure the specific latent heat of vaporization of water, steam at 100°C was passed into water in an insulated container.

The following data are available.

- Initial mass of water in container = 0.260 kg
- Final mass of water in container = 0.278 kg
- Initial temperature of water in container = 20.4 °C
- Final temperature of water in container = 53.4 °C
- Specific heat capacity of water = $4.18 \times 10^3 \text{ J kg}^{-1} \text{ K}^{-1}$

Show that the specific latent heat of vaporization of water is about $1.8 \times 10^6 \text{ J kg}^{-1}$.

(4 marks)

(c) The accepted value of L is greater than that given in part (b).

Explain why, other than through experimental or calculation error, this is the case.

(2 marks)

- (d) The insulated container is replaced with one made of iron and the experiment is repeated with the same starting temperature and masses of steam and water.

After a period of time, the container reaches thermal equilibrium with the water at a temperature of 30.7 °C. The specific heat capacity of iron is 447 J kg⁻¹ K⁻¹.

Assuming no energy is lost to the surroundings, calculate the mass of the container.

(3 marks)

3 (a) This question is about thermal energy transfers involved in sweating.

Distinguish between the concepts of temperature and internal energy.

(3 marks)

(b) An athlete loses 2.4 kg of water through sweat whilst training for 2 hours.

Estimate the rate of energy loss by the athlete due to sweating. The specific latent heat of vaporization of water is $2.3 \times 10^6 \text{ J kg}^{-1}$.

(2 marks)

(c) The athlete sits down to rest on an aluminium chair of mass 40 kg following her training session.

The temperature of the athlete is $37.8 \text{ }^\circ\text{C}$ and the temperature of the chair is 293 K . The specific heat capacity of aluminium is $900 \text{ J kg}^{-1} \text{ K}^{-1}$.

- (i) Outline two properties that can be determined by the relative temperatures of the athlete and the chair. [2]

- (ii) Calculate the amount of energy transferred to the chair in order to change its temperature to be in thermal equilibrium with the athlete.

Assume the athlete maintains a constant temperature.

[2]

(4 marks)

(d) When the sweat evaporates from the athlete it turns from a liquid to a gas.

State, in terms of molecular structure and motion, two differences between a liquid and a gas.

(2 marks)

4 (a) This question is about a slowly melting iceberg.

Distinguish the difference between liquid water and solid ice, with reference to molecular motion and energy.

.....
.....

(2 marks)

(b) The following data is available regarding an iceberg:

- The iceberg has a density of 920 kg m^{-3}
- The temperature of the iceberg is $-25 \text{ }^\circ\text{C}$
- The volume of the iceberg is $78\,000 \text{ m}^3$
- The specific latent heat of fusion of ice is $3.3 \times 10^5 \text{ J kg}^{-1}$
- The specific heat capacity of ice is $2.1 \times 10^3 \text{ J kg}^{-1} \text{ K}^{-1}$

Calculate the energy required to melt the iceberg to form water at 0°C .

.....
.....
.....
.....

(4 marks)

(c) The Sun supplies thermal energy to the iceberg at an average rate of 450 W m^{-2} . Assume that the iceberg has a consistent surface area of 312 m^2 .

Estimate the time taken, in years, to melt the iceberg, assuming the melted water is immediately removed, and no heat is lost to the surroundings.

.....
.....
.....

(3 marks)

- (d) In reality, there is heat transferred between the sea, which is at a temperature greater than 0°C , and the iceberg.

Outline what effect this will have on the rate of melting of the iceberg.

(2 marks)

5 (a) This question is about an experiment to examine how the specific heat capacity of water varies with temperature.

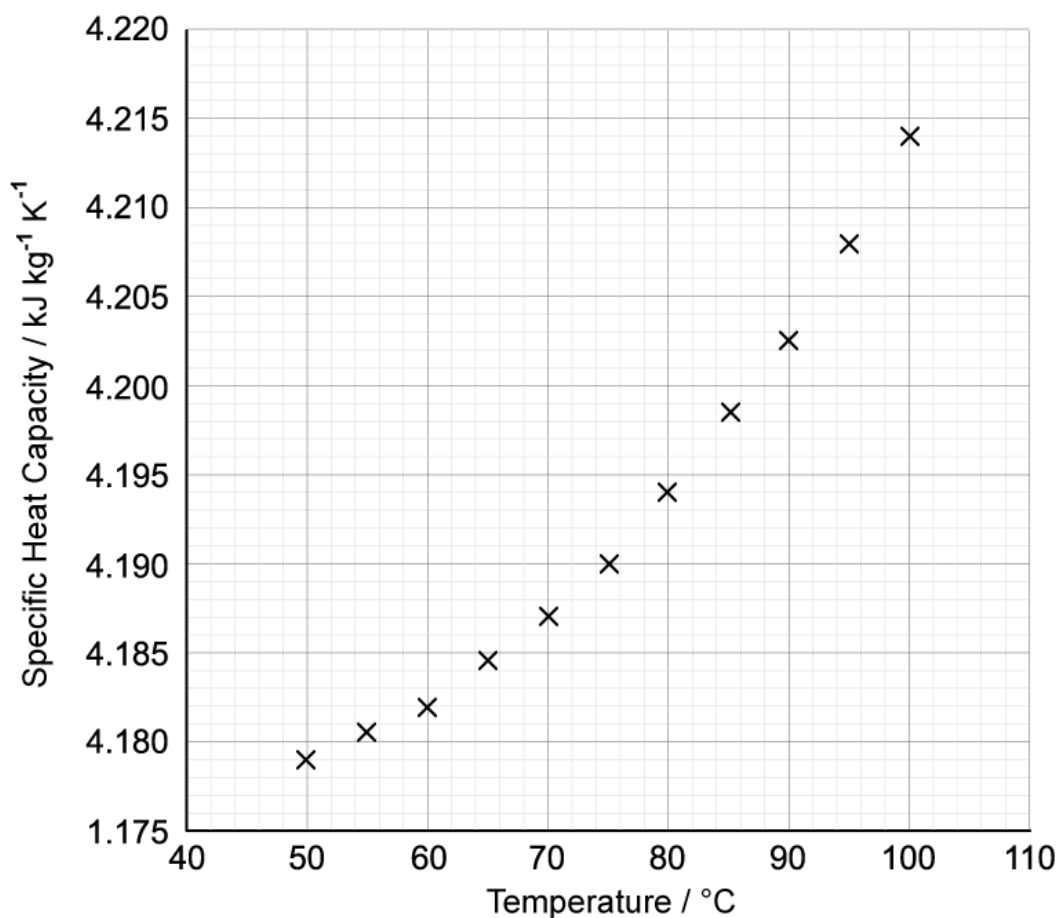

Draw the line of best fit for the data.

(2 marks)

(b) (i) Determine the gradient of the line at a temperature of 70 °C.

[2]

(ii) State the unit for the quantity represented by the gradient.

[1]

(3 marks)

- (c) (i) Estimate the area under the curve and give the unit. [2]
- (ii) State what the area represents. [1]

(3 marks)

- (d) The experiment used water that reached a height of 40 cm in a cylindrical can of diameter 50 cm. The average density of water between 70 °C and 90 °C is 970 kg m⁻³.
- (i) Estimate the mass of water used in this experiment. [2]
- (ii) Hence, estimate the amount of energy transferred heating the water from 70 °C to 90 °C. [1]

(3 marks)

Hard Questions

1 (a) Four identical ice cubes are dropped into a thermally isolated cylinder containing water.

Side length of each ice cube	1.9 cm
Density of ice	920 kg m^{-3}
Initial temperature of ice cubes	-5.6°C
Mass of water in the container	825 g
Initial temperature of water	19.75°C
Specific heat capacity of ice	$2.1 \text{ kJ kg}^{-1} \text{ K}^{-1}$
Specific latent heat of fusion of ice	0.336 MJ kg^{-1}
Specific heat capacity of water	$4.2 \text{ kJ kg}^{-1} \text{ K}^{-1}$

Sketch a graph to show how the temperature of the ice varies with time; from the point they are added to the water until they are in thermal equilibrium.

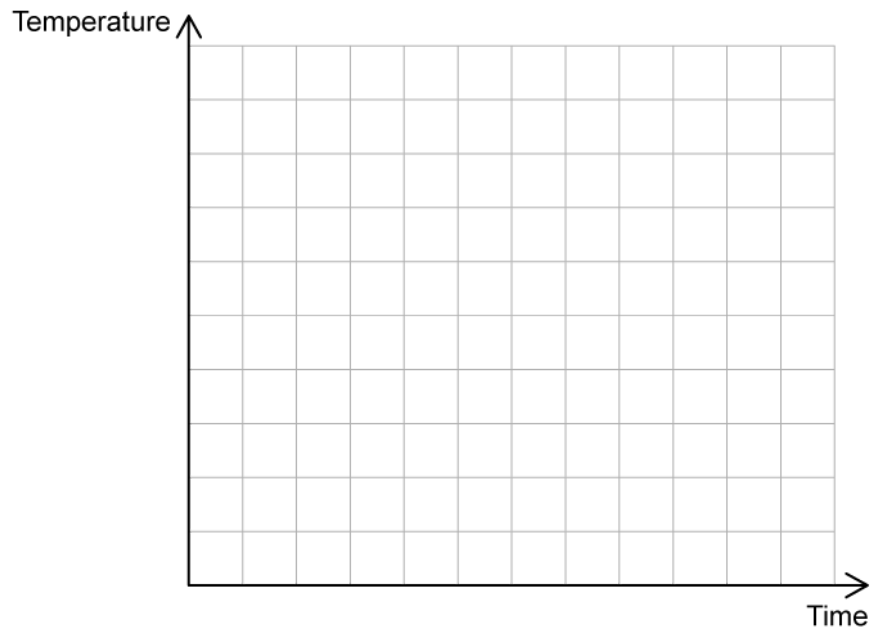

.....

.....

.....

.....

(4 marks)

(b) Calculate the final temperature of the water.

.....

.....

.....

.....

(4 marks)

(c) The experiment is repeated with the same mass of ice but formed into triangular prisms instead of cubes.

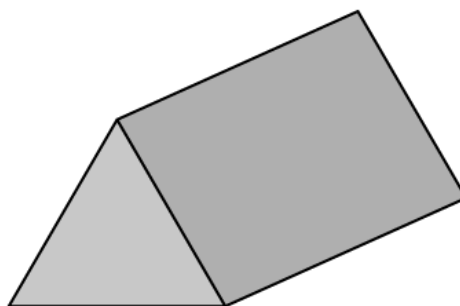

State and explain the similarities and differences that be would be observed when repeating this experiment.

(3 marks)

- (d) The process is now carried out using a container that is not thermally isolated from its surroundings. The air temperature in the room where the process is repeated is $25\text{ }^{\circ}\text{C}$.

Describe and explain how the final temperature of the water will be different from your answer to part (b)).

(2 marks)

- 2 A meteorite of pure nickel with a constant mass of 3.9 kg falls to Earth and begins to accelerate uniformly from the atmosphere's edge at a height $h_A = 225\text{ km}$ and velocity 95 m s^{-1} . Initially in the atmosphere, it accelerates, reaches a constant velocity and continues to fall. It falls into a circular pond of water at a temperature of $18\text{ }^{\circ}\text{C}$ with a velocity of 125 m s^{-1} .

The pond has a radius of 3.5 m and a depth of 70 cm . The nickel has a specific heat capacity of $0.44\text{ J g}^{-1}\text{ K}^{-1}$ and had a temperature of $-270\text{ }^{\circ}\text{C}$ before it started to fall.

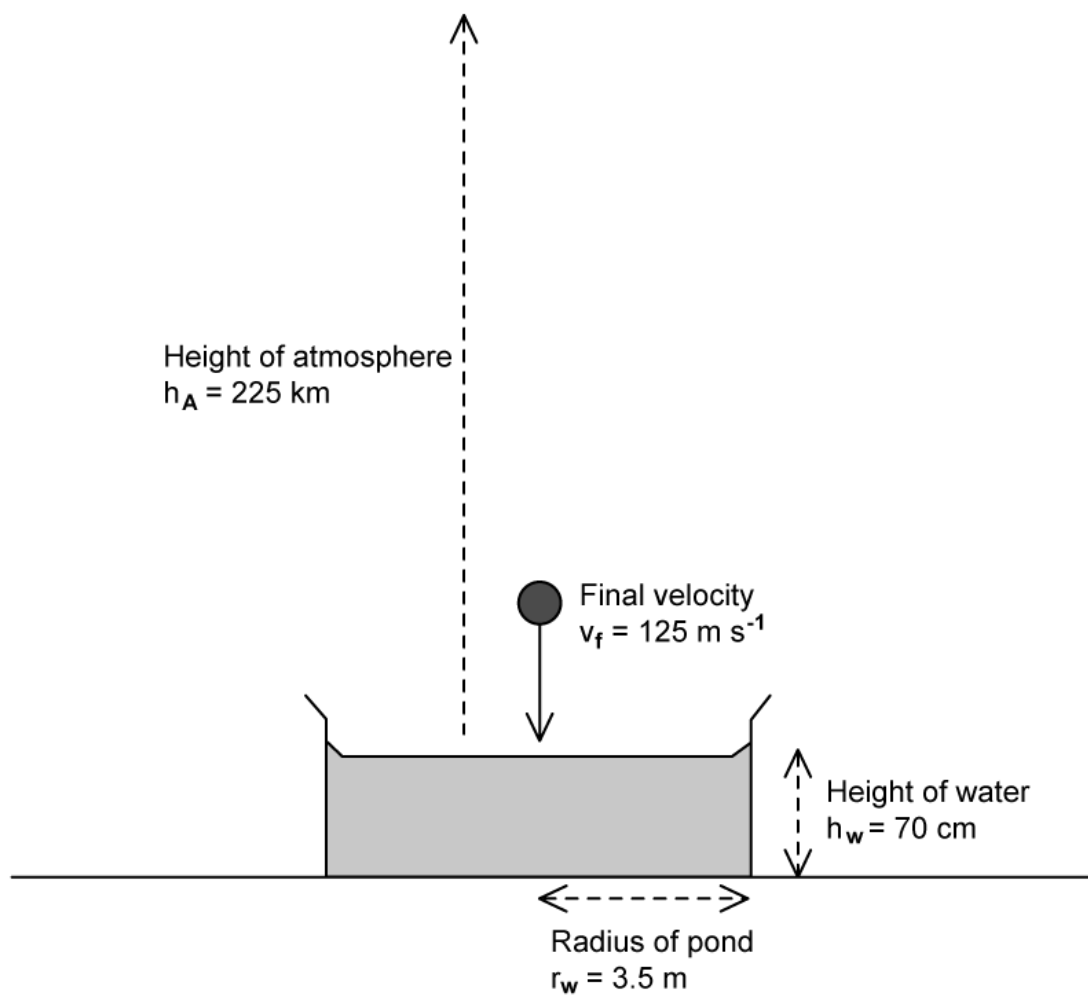

- (i) Calculate the temperature of the meteorite immediately before it hits the ground. [2]
- (ii) Explain whether this figure is likely to be similar to the real value of the temperature of the meteorite upon hitting the ground. [2]

(4 marks)

- 3 (a)** A car of mass 875 kg is travelling on a flat road at a constant speed of 35 m s^{-1} . An obstacle appears in the road, the brakes are applied and the car comes to a stop.

The car has four brake disks and each has a mass of 1.3 kg. The specific heat capacity of the brake disk material is $460 \text{ J kg}^{-1} \text{ K}^{-1}$.

Calculate the overall increase in the temperature of the disks.

(2 marks)

- (b)** When brakes are applied in a car, incompressible brake fluid forces the brake pads into place. The brake fluid heats up because it is in contact with the brake pads. It must not boil, or it will compress and the brakes will not work.

A certain brand of brake fluid uses a material called glycol. Engineers with the brand are investigating mixing some water with glycol to make the brake fluid less likely to overheat.

Specific heat capacity of glycol	$2.4 \text{ kJ kg}^{-1} \text{ K}^{-1}$
Boiling temperature of glycol	$195 \text{ }^\circ\text{C}$
Specific heat capacity of water	$4.2 \text{ kJ kg}^{-1} \text{ K}^{-1}$
Boiling temperature of water	100°C

Evaluate whether adding water to glycol will make the brake fluid safer from overheating.

(3 marks)

- (c) A car manufacturer is developing brakes that bring the car to a stop over the same distance whether the car is going up or downhill.

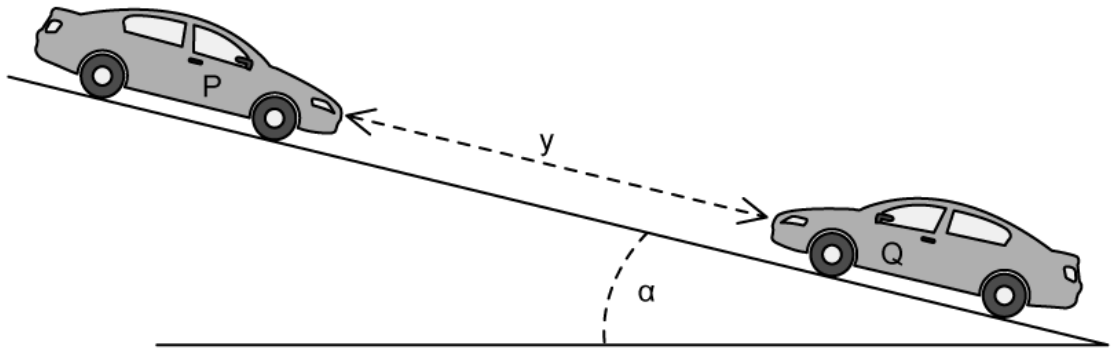

Cars P and Q are on a slope at an angle α to the horizontal and at a distance of y m apart. The cars have an identical mass, m , velocity, v and four identical brake pads of mass m_D .

Determine an expression for the difference in temperature increase of the brake pads of each car when they both come to a stop after braking over a distance of $\frac{y}{2}$.

(4 marks)

- 4 (a) An electrical immersion heater with a power of 5 kW is used to heat water flowing past it in a cylinder. The water flows through the heating cylinder at a rate of 0.11 kg s^{-1} . Valves at the beginning and end of the cylinder prevent the water from flowing backwards.

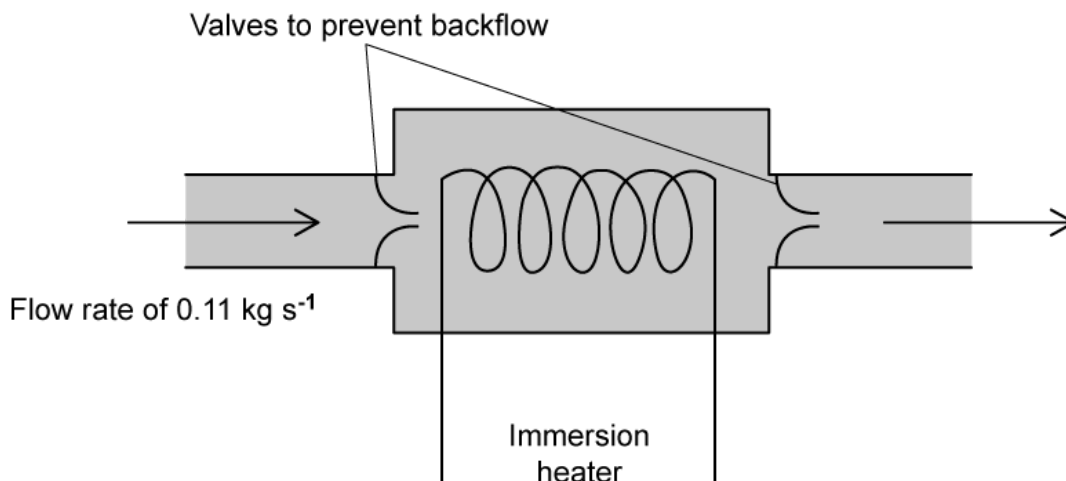

The specific heat capacity of water is $4200 \text{ J kg}^{-1} \text{ K}^{-1}$.

Calculate the rise in temperature of the water as it flows through the heater.

Assume all the energy is transferred to the water.

(2 marks)

- (b) A fault in the pump that pushes water through the heater causes the water to stop flowing. The valves at each end of the heating cylinder close and the water inside continues to heat. The closed cylinder has a length of 31.2 cm and a diameter of 12.6 cm.

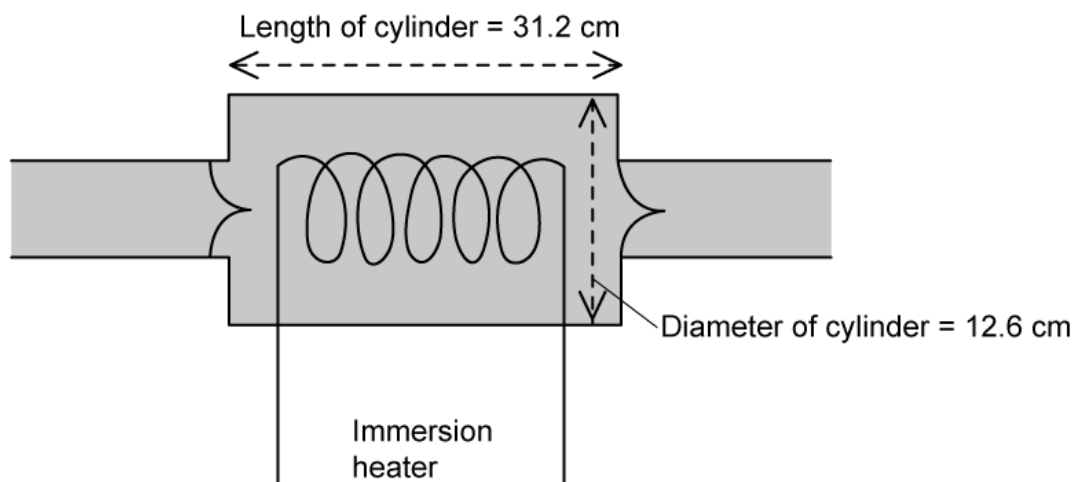

The water temperature is $21.5\text{ }^{\circ}\text{C}$ when the valves are shut. Water has a density of 1000 kg m^{-3} .

Calculate the time taken for the water to boil at $100\text{ }^{\circ}\text{C}$ if the immersion heater continues supplying energy at the same rate.

(2 marks)

- (c) There are two main methods that are used to measure the specific heat capacity of liquids.

Method A:
Immersion Heater

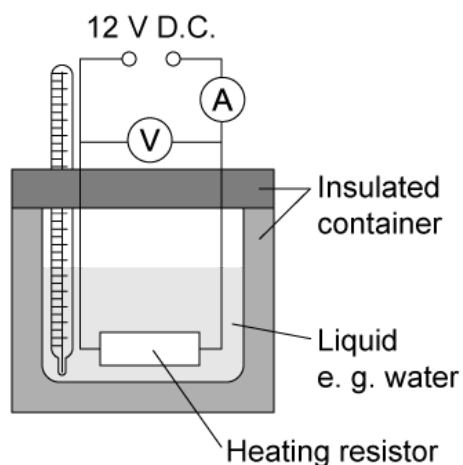

Method B:
Continuous flow

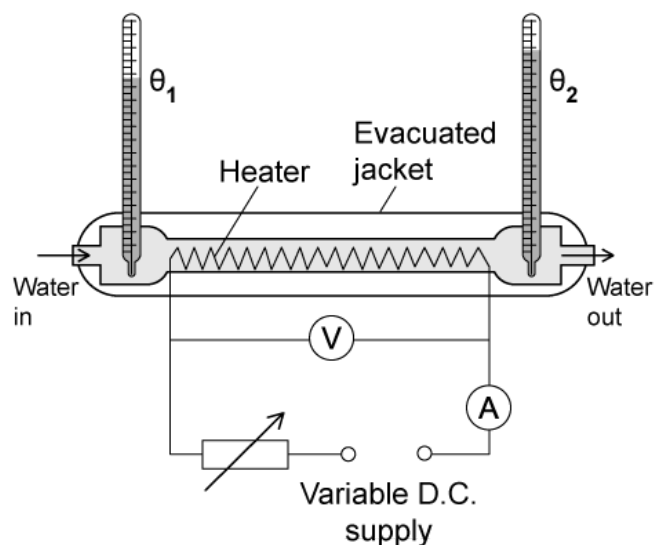

Method A, Immersion Heater: involves submerging an immersion heater in the liquid to be tested.

Method B, Continuous Flow: involves flowing the liquid to be tested past a heater.

Discuss the two different methods for measuring the specific heat capacity of a liquid.

In your answer:

- Explain how a value for the specific heat capacity is obtained
- Explain any systematic problems with the methods, and how they will affect the final result
- Explain how a continuous flow method can compensate for energy lost as thermal radiation during the experiment

(6 marks)

- 5 (a)** An unopened soda drinks can is cooled using an electric chiller that is powered using a USB connection with a laptop computer. The chiller is advertised as using 37 W of power and cools drinks to 12 °C from any room temperature and then maintains the drink at that temperature.

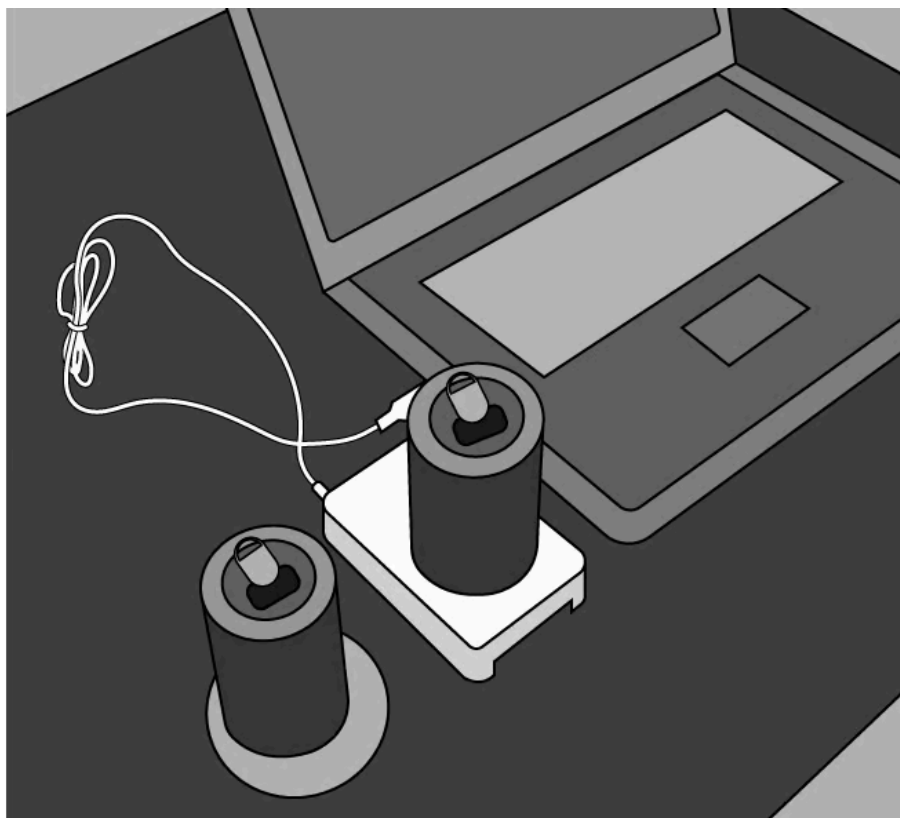

A can of soda has a mass of 16 g when empty, and contains 324 g of soda. The can is a metal alloy that has a specific heat capacity of $800 \text{ J kg}^{-1} \text{ K}^{-1}$ and the soda has a specific heat capacity of $3700 \text{ J kg}^{-1} \text{ K}^{-1}$.

Calculate the time it takes to cool the can from a room temperature of 23 °C to 12 °C.

(2 marks)

- (b)** An alternative way to cool drinks is to add ice to them. Ice can be made in an ice maker. A particular model advertises that it can produce 15 kg of ice in 24 hours and requires 230 W when working. It produces ice cubes at a temperature of $-5 \text{ }^\circ\text{C}$.



The specific latent heat of fusion of ice is 0.336 MJ kg^{-1} .

The specific heat capacity of ice is $2100 \text{ J kg}^{-1} \text{ K}^{-1}$.

The specific heat capacity of water is $4100 \text{ J kg}^{-1} \text{ K}^{-1}$.

Determine whether the ice cube maker or the electric chiller from part (a) is a more energy efficient method for cooling drinks from $23 \text{ }^\circ\text{C}$ to $12 \text{ }^\circ\text{C}$.

.....

.....

.....

.....

.....

(5 marks)